

SimEvents®

User's Guide



MATLAB® & SIMULINK®

R2019b



How to Contact MathWorks



Latest news: www.mathworks.com
Sales and services: www.mathworks.com/sales_and_services
User community: www.mathworks.com/matlabcentral
Technical support: www.mathworks.com/support/contact_us



Phone: 508-647-7000



The MathWorks, Inc.
1 Apple Hill Drive
Natick, MA 01760-2098

SimEvents[®] *User's Guide*

© COPYRIGHT 2005–2019 by The MathWorks, Inc.

The software described in this document is furnished under a license agreement. The software may be used or copied only under the terms of the license agreement. No part of this manual may be photocopied or reproduced in any form without prior written consent from The MathWorks, Inc.

FEDERAL ACQUISITION: This provision applies to all acquisitions of the Program and Documentation by, for, or through the federal government of the United States. By accepting delivery of the Program or Documentation, the government hereby agrees that this software or documentation qualifies as commercial computer software or commercial computer software documentation as such terms are used or defined in FAR 12.212, DFARS Part 227.72, and DFARS 252.227-7014. Accordingly, the terms and conditions of this Agreement and only those rights specified in this Agreement, shall pertain to and govern the use, modification, reproduction, release, performance, display, and disclosure of the Program and Documentation by the federal government (or other entity acquiring for or through the federal government) and shall supersede any conflicting contractual terms or conditions. If this License fails to meet the government's needs or is inconsistent in any respect with federal procurement law, the government agrees to return the Program and Documentation, unused, to The MathWorks, Inc.

Trademarks

MATLAB and Simulink are registered trademarks of The MathWorks, Inc. See www.mathworks.com/trademarks for a list of additional trademarks. Other product or brand names may be trademarks or registered trademarks of their respective holders.

Patents

MathWorks products are protected by one or more U.S. patents. Please see www.mathworks.com/patents for more information.

Revision History

November 2005	Online only	New for Version 1.0 (Release 14SP3+)
March 2006	Online only	Revised for Version 1.1 (Release 2006a)
September 2006	Online only	Revised for Version 1.2 (Release 2006b)
March 2007	Online only	Revised for Version 2.0 (Release 2007a)
September 2007	Online only	Revised for Version 2.1 (Release 2007b)
March 2008	Online only	Revised for Version 2.2 (Release 2008a)
October 2008	Online only	Revised for Version 2.3 (Release 2008b)
March 2009	Online only	Revised for Version 2.4 (Release 2009a)
September 2009	Online only	Revised for Version 3.0 (Release 2009b)
March 2010	Online only	Revised for Version 3.1 (Release 2010a)
September 2010	Online only	Revised for Version 3.1.1 (Release 2010b)
April 2011	Online only	Revised for Version 3.1.2 (Release 2011a)
September 2011	Online only	Revised for Version 4.0 (Release 2011b)
March 2012	Online only	Revised for Version 4.1 (Release 2012a)
September 2012	Online only	Revised for Version 4.2 (Release 2012b)
March 2013	Online only	Revised for Version 4.3 (Release 2013a)
September 2013	Online only	Revised for Version 4.3.1 (Release 2013b)
March 2014	Online only	Revised for Version 4.3.2 (Release 2014a)
October 2014	Online only	Revised for Version 4.3.3 (Release 2014b)
March 2015	Online only	Revised for Version 4.4 (Release 2015a)
September 2015	Online only	Revised for Version 4.4.1 (Release 2015b)
March 2016	Online only	Revised for Version 5.0 (Release 2016a)
September 2016	Online only	Revised for Version 5.1 (Release 2016b)
March 2017	Online only	Revised for Version 5.2 (Release 2017a)
September 2017	Online only	Revised for Version 5.3 (Release 2017b)
March 2018	Online only	Revised for Version 5.4 (Release 2018a)
September 2018	Online only	Revised for Version 5.5 (Release 2018b)
March 2019	Online only	Revised for Version 5.6 (Release 2019a)
September 2019	Online only	Revised for Version 5.7 (Release 2019b)

Working with Entities

Events and Event Actions	1-2
Create Event Actions	1-2
Event Action Languages and Random Number Generation ...	1-5
Guidelines for Using MATLAB as the Event Action Language	1-5
Generate Random Numbers with Event Actions	1-6
Parameters in Event Actions	1-11
Generate Entities When Events Occur	1-12
Generate Entity When First Entity is Destroyed	1-12
Generate Event-Based Entities Using Data Sets	1-14
Specify Intergeneration Times for Entities	1-16
Determine Intergeneration Time	1-16
Generate Multiple Entities at Time Zero	1-23
Build the model	1-23
Adjust Entity Generation Times Through Feedback	1-26
Count Simultaneous Departures from a Server	1-30
Noncumulative Counting of Entities	1-33
Working with Entity Attributes	1-37
Attach Attributes	1-37
Set Attributes	1-37
Manipulate Entity Attributes	1-40
Write Functions to Manipulate Attributes	1-40

Inspect Structures of Entities	1-44
Display Entity Types	1-44
Inspect Entities at Run Time	1-45
Generate Entities Carrying Nested Data Structures	1-47
Model Resource Allocation Using Composite Entity Creator block	1-53
Replicate Entities on Multiple Paths	1-54
Modeling Notes	1-54
Measure Point-to-Point Delays	1-56
Basic Example Using Timer Blocks	1-56
Attribute Value Support	1-61

Modeling Queues and Servers

2

Model Basic Queuing Systems	2-2
Example of a Logical Queue	2-2
Vary the Service Time of a Server	2-2
Sort by Priority	2-6
Behavior of Priority Mode of Entity Queue Block	2-6
Serving Preferred Customers First	2-6
Task Preemption in a Multitasking Processor	2-9
Example Model for Task Preemption	2-9
Model Behavior and Results	2-9
Determine Whether a Queue Is Nonempty	2-12
Model Server Failure	2-13
Server States	2-13
Use a Gate to Implement a Failure State	2-13

Role of Paths in SimEvents Models	3-2
Definition of Entity Paths	3-2
Implications of Entity Paths	3-2
Overview Blocks for Designing Paths	3-2
Route Vehicles Using an Entity Output Switch Block	3-4
Control Output Switch with Event Actions and Simulink	
Function	3-8
Control Output Switch with a Simulink Function Block	3-8
Specify an Initial Port Selection	3-9
Match Entities Based on Attributes	3-11
Use Attributes to Route Entities	3-13
Role of Gates in SimEvents Models	3-14
Overview of Gate Behavior	3-14
Gate Behavior	3-15
Enable a Gate for a Time Interval	3-16
Behavior of Entity Gate Block in Enabled Mode	3-16
Sense an Entity Passing from A to B and Open a Gate	3-16
Control Joint Availability of Two Servers	3-18

Model Using Resources	4-2
Resource Blocks	4-2
Resource Creation Workflow	4-2
Set Resource Amount with Attributes	4-4
Process Batched Entities Using Event Actions	4-6

Find and Extract Entities in SimEvents Models	4-10
Finding and Examining Entities	4-10
Extracting Found Entities	4-15
Changing Found Entity Attributes	4-18
Triggering Entity Find Block with Event Actions	4-19
Building a Firewall and an Email Server	4-21

Visualization, Statistics, and Animation

5

Interpret SimEvents Models Using Statistical Analysis	5-2
Output Statistics for Data Analysis	5-2
Output Statistics for Run-Time Control	5-2
Average Queue Length and Average Store Size	5-6
Average Wait	5-9
Number of Entities Arrived	5-11
Number of Entities Departed	5-11
Number of Entities Extracted	5-12
Number of Entities in Block	5-12
Number of Pending Entities	5-12
Pending Entity Present in Block	5-12
Utilization	5-12
Visualization and Animation for Debugging	5-14
Which Debugging Tool to Use	5-14
Observe Entities with Animation	5-15
Explore the System Using the Simulink Simulation Stepper .	5-15
Information About Race Conditions and Random Times	5-16
Model Traffic Intersections as a Queuing Network	5-17
Optimize SimEvents Models by Running Multiple Simulations	5-26
Grocery Store Model	5-26
Build the Model	5-27
Run Multiple Simulations to Optimize Resources	5-28
Use the Sequence Viewer Block to Visualize Messages, Events, and Entities	5-32
Components of the Sequence Viewer Window	5-34

Navigate the Lifeline Hierarchy	5-36
View State Activity and Transitions	5-39
View Function Calls	5-41
Simulation Time in the Sequence Viewer Window	5-41
Redisplay of Information in the Sequence Viewer Window ..	5-42

Learning More About SimEvents Software

6

Event Calendar	6-2
Entity Priorities	6-3
Livelock Prevention	6-5
Large Finite Numbers of Simultaneous Events	6-5
Save SimEvents Simulation Operating Point	6-6
Example Model to Count Simultaneous Departures from a Server	6-12
Example Model for Noncumulative Entity Count	6-13
Example Model for Discouraged Arrival	6-14
A Simple Example of Generating Multiple Entities	6-15
A Simple Example of Event-Based Entity Generation	6-16
Serve Preferred Customers First	6-17
Find and Examine Entities	6-18
Extract Found Entities	6-21
Trigger Entity Find Block with Event Actions	6-22
Build a Firewall and an Email Server	6-23

Implement the Custom Entity Storage Block	6-24
Implement the Custom Entity Storage Block with Iteration Event	6-25
Implement the Custom Entity Storage Block with Two Timer Events	6-26
Implement the Custom Entity Generator Block	6-27
Implement the Custom Entity Storage Block with Two Storages	6-28

Use SimEvents with Simulink

7

Working with SimEvents and Simulink	7-2
Exchange Data Between SimEvents and Simulink	7-2
Time-Based Signals and SimEvents Block Transitions	7-2
SimEvents Support for Simulink Subsystems	7-2
Save Simulation Data	7-4
Solvers for Discrete-Event Systems	7-6
Variable-Step Solvers for Discrete-Event Systems	7-6
Fixed-Step Solvers for Discrete-Event Systems	7-7
Model Simple Order Fulfilment Using Autonomous Robots ..	7-9
Order Fulfilment Model	7-9
Warehouse Component	7-10
Order Queue Component	7-15
Results	7-16

Build Discrete-Event Systems Using Charts

8

Discrete-Event Stateflow Charts	8-2
Why Use the Discrete-Event Chart	8-2

How Discrete-Event Charts Differ from Stateflow Charts	8-4
Discrete Event Chart Properties	8-4
Define Message (Entity) Input and Output	8-5
Define Local Messages	8-5
Specify Message Properties	8-5
Event Triggering in Discrete-Event Charts	8-6
Event Triggering	8-6
Message Triggering	8-6
Temporal Triggering	8-7
Discrete-Event Chart Precise Timing	8-9
Trigger a Discrete-Event Chart Block on Message Arrival . . .	8-13
Dynamic Scheduling of Discrete-Event Chart Block	8-25

Build Discrete-Event Systems Using System Objects

9

Create Custom Blocks Using MATLAB Discrete-Event System Block	9-2
Entity Types, Ports, and Storage in a Discrete-Event System Framework	9-3
Events	9-6
Implement a Discrete-Event System Object with MATLAB Discrete-Event System Block	9-7
Delay Entities with a Custom Entity Storage Block	9-11
Create the Discrete-Event System Object	9-11
Implementing the Custom Entity Storage Block	9-14
Create a Custom Entity Storage Block with Iteration Event	9-17
Create the Discrete-Event System Object	9-17
Define Custom Block Behavior	9-19
Implement Custom Block	9-19

Custom Entity Storage Block with Multiple Timer Events . . .	9-23
Create the Discrete-Event System Object with Multiple Timer Events	9-23
Custom Block Behavior	9-25
Implement Custom Block	9-26
Custom Entity Generator Block with Signal Input	9-31
Create the Discrete-Event System Object	9-31
Custom Block Behavior	9-33
Implement Custom Block	9-35
Build a Custom Block with Multiple Storages	9-39
Create the Discrete-Event System Object	9-39
Custom Block Behavior	9-42
Implement the Custom Block	9-44
Create a Custom Resource Acquirer Block	9-49
Create the Discrete-Event System Object	9-49
Custom Block Behavior	9-51
Implement the Custom Block	9-51
Create a Discrete-Event System Object	9-58
Methods	9-59
Inherited Methods from matlab.System Class	9-62
Inherited Methods from matlab.system.mixin Package	9-62
Reference and Extract Entities	9-63
Generate Code for MATLAB Discrete-Event System Blocks . .	9-65
Migrate Existing MATLAB Discrete-Event System System object	9-65
Limitations of Code Generation with Discrete-Event System Block	9-68
Customize Discrete-Event System Behavior Using Events and Event Actions	9-69
Event Types and Event Actions	9-69
Event Identifiers	9-72
Call Simulink Function from a MATLAB Discrete-Event System Block	9-75
Modify Entity Attributes	9-76
Build the Model	9-76

Resource Scheduling Using MATLAB Discrete-Event System and Data Store Memory Blocks	9-80
--	-------------

Custom Visualization

10

Use SimulationObserver Class to Monitor a SimEvents Model	10-2
SimulationObserver Class	10-2
Custom Visualization Workflow	10-2
Create an Application	10-3
Use the Observer to Monitor the Model	10-5
Stop Simulation and Disconnect the Model	10-5
 Custom Visualization Example	 10-6
Structure of Example Model	10-6
Visualize Entities	10-6
 Observe Entities Using simevents.SimulationObserver Class	 10-8

Migrating SimEvents Models

11

Migration Considerations	11-2
When You Should Not Migrate	11-3
 Migration Workflow	 11-4
 Identify and Redefine Entity Types	 11-7
 Replace Old Blocks	 11-9
 Connect Signal Ports	 11-13
If Connected to Gateway Blocks	11-13
If Using Get Attribute Blocks to Observe Output	11-13
If Connected to Computation Blocks	11-14

If Connected to Reactive Ports	11-16
Write Event Actions for Legacy Models	11-19
Replace Set Attribute Blocks with Event Actions	11-19
Get Attribute Values	11-20
Replace Random Number Distributions in Event Actions ..	11-21
Replace Event-Based Sequence Block with Event Actions ..	11-22
Replace Attribute Function Blocks with Event Actions	11-23
If Using Simulink Signals in an Event-Based Computation .	11-27
Observe Output	11-29
Reactive Ports	11-31

Troubleshoot SimEvents Models

12

Debug SimEvents Models	12-2
Start the Debugger	12-3
Step Through Model	12-4

Working with Entities

- “Events and Event Actions” on page 1-2
- “Event Action Languages and Random Number Generation” on page 1-5
- “Generate Entities When Events Occur” on page 1-12
- “Specify Intergeneration Times for Entities” on page 1-16
- “Generate Multiple Entities at Time Zero” on page 1-23
- “Adjust Entity Generation Times Through Feedback” on page 1-26
- “Count Simultaneous Departures from a Server” on page 1-30
- “Noncumulative Counting of Entities” on page 1-33
- “Working with Entity Attributes” on page 1-37
- “Manipulate Entity Attributes” on page 1-40
- “Inspect Structures of Entities” on page 1-44
- “Generate Entities Carrying Nested Data Structures” on page 1-47
- “Model Resource Allocation Using Composite Entity Creator block” on page 1-53
- “Replicate Entities on Multiple Paths” on page 1-54
- “Measure Point-to-Point Delays” on page 1-56
- “Attribute Value Support” on page 1-61

Events and Event Actions

In a discrete-event simulation, an event is an observation of an instantaneous incident that may change a state variable, an output, and/or the occurrence of other events. You can create event actions to occur when entities change state, for example, when an entity exits a block. For a list of blocks and the actions they can have, see “Storage Actions”.

An event calendar tracks upcoming events for a model during a discrete-event simulation. For more information on the event calendar, see “Event Calendar” on page 6-2.

The event actions assistant helps you create repeated sequence of event actions or random event actions according to a statistical distribution. For more information on the event actions assistant, see “Event Actions Assistant for Events”.

Create Event Actions

Define event actions on the **Event actions** tab of a block. These are the possible actions for which you can create events.

Entity Generator	Entity Queue	Entity Server	Entity Terminator	Resource Acquirer	Entity Batch Creator
Entity generation	Entity entry to queue block	Entity entry to server block	Entity entry to terminator block	Entity entry to acquirer block	Entity entry to batch block
Entity exit from block	Entity exit from block	Service completion of entity	N/A	Entity exit from acquirer block	Entity batch generation
N/A	Entity is blocked	Entity exit from block	N/A	Entity is blocked	Entity exit from block
N/A	N/A	Entity is blocked	N/A	N/A	Entity is blocked
N/A	N/A	Entity is preempted	N/A	N/A	N/A

In event actions, you can also modify entity attributes (*entityName.attributeName*), entity priorities (`sys.entity.priority`), and entity IDs (`sys.entity.id`). However, you cannot change these entity attributes or its system properties (`entitySys`) for exit actions in any block. Attempting to change these values causes an error at simulation.

The `seExampleTankFilling` example has two event actions defined, in the Entity Generator and Entity Server blocks. This example recreates the event action in the Entity Server block.

1 In a new model, from the SimEvents library, drag the Entity Server and Simulink Function blocks.

2 In the Entity Server block:

- Click the **Entity actions** tab.
- To create an action on entity entry, click **Entry**.
- In the **Entry action** section, type:

```
startFilling(entity.Capacity);
```

This command calls the function, `startFilling`.

The ingoing line to the Entity Server block icon updates with the event action icon (`{...}`) indicating that the block defines an event action.

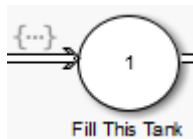

3 In the Simulink Function block:

- a** In Trigger Port, enter `startFilling` in the **Function name** parameter.
- b** Drag in an Inport block and rename it to `cap`.
- c** Rename the `u` input to `capacity` and connect it to `cap`.
- d** Remove the `y` output.
- e** Drag in a MATLAB Function block and an Outport block.
- f** In the MATLAB Function, enter the code:

```
function y = toggle()
%#codegen
persistent u

if isempty(u)
    u = -1;
end
```

```
if u == -1
    u = 1;
else
    u = -1;
end

y = u;
```

- 9 Connect the y output of the MATLAB Function block to the Outport block and rename the Outport block to reset.

You have now defined the `startFilling` function for the event action. To optionally visualize the connection between the Entity Server block and the Simulink Function block, in the Editor, select **Display > Function Connectors**.

See Also

Composite Entity Creator | Composite Entity Splitter | Discrete Event Chart | Entity Gate | Entity Generator | Entity Input Switch | Entity Multicast | Entity Output Switch | Entity Queue | Entity Replicator | Entity Server | Entity Terminator | MATLAB Discrete Event System | Multicast Receive Queue | Resource Acquirer | Resource Pool | Resource Releaser

Related Examples

- “Generate Entities When Events Occur” on page 1-12

More About

- “Entities in a SimEvents Model”
- “Role of Events in a SimEvents Model”
- “Event Action Languages and Random Number Generation” on page 1-5
- “Event Calendar” on page 6-2

Event Action Languages and Random Number Generation

In this section...

“Guidelines for Using MATLAB as the Event Action Language” on page 1-5

“Generate Random Numbers with Event Actions” on page 1-6

“Parameters in Event Actions” on page 1-11

You can write SimEvents actions using:

- MATLAB® code — Use MATLAB. For information on guidelines for using MATLAB code as the event action language, see “Guidelines for Using MATLAB as the Event Action Language” on page 1-5
- Simulink® functions — Use the Simulink Function block. The Simulink Function block does not accept entities as input.

Guidelines for Using MATLAB as the Event Action Language

In general, using MATLAB as the SimEvents event action language follows the same rules as the use of MATLAB in the MATLAB Function block.

- Include a type prefix for identifiers of enumerated values — The identifier `TrafficColors.Red` is valid, but `Red` is not.
- Use the MATLAB format for comments — Use `%` to specify comments for consistency with MATLAB. For example, the following comment is valid:

```
% This is a valid comment in the style of MATLAB
```

- Use one-based indexing for vectors and matrices — One-based indexing is consistent with MATLAB syntax.
- Use parentheses instead of brackets to index into vectors and matrices — This statement is valid:

```
a(2,5) = 0;
```

This statement is not valid:

```
a[2][5] = 0;
```

- Persistent variable guidelines:
 - Manage states that are not part of the entity structure using MATLAB persistent variables.
 - Persistent variables defined in any event action of a block are scoped to only that action.
 - Block can share persistent variables across all of its event action by managing it in a MATLAB function on path (that is invoked from its event actions).
 - Two different blocks cannot share the same persistent variable.
- Assign an initial value to local and output data — When using MATLAB as the action language, data read without an initial value causes an error.
- Do not use parameters that are of data type cell array.

Generate Random Numbers with Event Actions

You can generate random numbers using various distributions. There are two modeling approaches to use seeds during random number generation.

- You can use persistent variables for initializing unique seeds for each block in your model.
- You can use `coder.extrinsic()` function to generate seeds without persistent variables.

To generate these random distributions, use code in the **Usage** column of this table in SimEvents blocks that support event actions or intergeneration time actions.

Distribution	Parameters	Usage	Requires Statistics and Machine Learning Toolbox™ Product
Exponential	Mean (m)	$-m * \log(1 - \text{rand})$	No
Uniform	Minimum (m) Maximum (M)	$m + (M - m) * \text{rand}$	No

Distribution	Parameters	Usage	Requires Statistics and Machine Learning Toolbox™ Product
Bernoulli	Probability for output to be 1 (P)	<code>binornd(1,P)</code>	Yes
Binomial	Probability of success in a single trial (P) Number of trials (N)	<code>binornd(N,P)</code>	Yes
Triangular	Minimum (m) Maximum (M) Mode (mode)	<pre>persistent pd if isempty(pd) pd = makedist('Triangular',... 'a',m,'b',mode,'c',M) end random(pd)</pre>	Yes
Gamma	Threshold (T) Scale (a) Shape (b)	<code>gamrnd(b,a)</code>	Yes
Gaussian (normal)	Mean (m) Standard deviation (d)	<code>m + d*randn</code>	No
Geometric	Probability of success in a single trial (P)	<code>geornd(P)</code>	Yes
Poisson	Mean (m)	<code>poissrnd(m)</code>	Yes
Lognormal	Threshold (T) Mu (mu) Sigma (S)	<code>T + lognrnd(mu,S)</code>	Yes

Distribution	Parameters	Usage	Requires Statistics and Machine Learning Toolbox™ Product
Log-logistic	Threshold (T) Scale (a)	<pre> persistent pd if isempty(pd) pd = makedist('Loglogistic',... 'mu',m,'sigma',S); end random(pd) </pre>	Yes
Beta	Minimum (m) Maximum (M) Shape parameter a (a) Shape parameter b (b)	betarnd(a,b)	Yes
Discrete uniform	Minimum (m) Maximum (M) Number of values (N)	<pre> persistent V P if isempty(V) step = (M-m)/N; V = m : step : M; P = 0 : 1/N : N; end r = rand; idx = find(r < P, 1); V(idx) </pre>	No
Weibull	Threshold (T) Scale (a) Shape (b)	T + wblrnd(a,b)	Yes

Distribution	Parameters	Usage	Requires Statistics and Machine Learning Toolbox™ Product
Arbitrary continuous	Value vector (V) Cumulative probability function vector (P)	<pre>r = rand; if r == 0 val = V(1); else idx = find(r < P,1); val = V(idx-1) + ... (V(idx)-V(idx-1))*(r-P(idx-1)); end</pre>	No
Arbitrary discrete	Value vector (V) Probability vector (P)	<pre>r = rand; idx = find(r < cumsum(P),1); V(idx)</pre>	No

For an example, see “Model Traffic Intersections as a Queuing Network” on page 5-17.

If you need additional random number distributions, see “Statistics and Machine Learning Toolbox”.

Random Number Distribution with Persistent Variables

To generate random numbers, initialize a unique seed for each block in your model. If you use a statistical pattern, you can manually change the initial seed to a unique value for each block to generate independent samples from the distributions.

To reset the initial seed value each time a simulation starts, use MATLAB code to initialize a persistent variable in event actions, for example:

```
persistent init
if isempty(init)
    rng(12234);
    init=true;
end
```

Here is an example code. The value vector is assigned to FinalStop:

```
% Set the initial seed.
persistent init
```

```
if isempty(init)
    rng(12234);
    init=true;
end
% Create random variable, x.
x=rand();
%
% Assign values within the appropriate range
% using the cumulative probability vector.
if x < 0.3
    entity.FinalStop = 2;
elseif x >= 0.3 && x < 0.6
    entity.FinalStop = 3;
elseif x >= 0.6 && x < 0.7
    entity.FinalStop = 4;
elseif x >= 0.7 && x < 0.9
    entity.FinalStop = 5;
else
    entity.FinalStop = 6;
end
```

Random Number Generation with Callbacks

In some scenarios, you generate random numbers without using the persistent variables. In this case, use `coder.extrinsic()` function to make sure that `SimEvents` is using the function in MATLAB and a seed is defined in the base workspace of MATLAB. This may cause performance decrease in simulation.

Consider this code as an example.

```
% Random number generation
coder.extrinsic('rand');
value = 1;
value = rand();
% Pattern: Exponential distribution
mu = 0.5;
dt = -1/mu * log(1 - value);
```

The output of the `extrinsic` function is an `mxAarray`. To convert it to a known type, a variable `val = 1` is declared to set its type to `double` and `rand` is assigned to that variable `val=rand`. For information about `extrinsic` functions, see “Working with `mxAarrays`” (Simulink).

For an example, see “Model Traffic Intersections as a Queuing Network” on page 5-17.

Parameters in Event Actions

From within an event action, you can refer to these parameters:

- Mask-specific parameters you define using the Mask Editor **Parameters** pane.
- Any variable you define in a workspace (such as base workspace or model workspace).
- Parameters you define using the `Simulink.Parameter` object.

Note With SimEvents actions, you cannot:

- Modify parameters from within an event action.
 - Tune parameters during simulation.
 - Event actions are not supported with string entity data type.
-

See Also

Entity Generator | Entity Queue | Entity Replicator | Entity Server | Entity Terminator | MATLAB Function | Multicast Receive Queue | Resource Acquirer | Simulink Function | `Simulink.Parameter`

Related Examples

- “Generate Entities When Events Occur” on page 1-12

More About

- “Role of Events in a SimEvents Model”
- “Mask Editor Overview” (Simulink)

Generate Entities When Events Occur

In this section...
“Generate Entity When First Entity is Destroyed” on page 1-12
“Generate Event-Based Entities Using Data Sets” on page 1-14

In addition to time-based entity generation, the Entity Generator block enables you to generate entities in response to events that occur during the simulation. In event-based generation, a new entity is generated whenever a message arrives at the input port of the Entity Generator block.

Event times and the time intervals between pairs of successive entities are not necessarily predictable in advance.

Generating entities when events occur is appropriate if you want the dynamics of your model to determine when to generate entities.

Generate Entity When First Entity is Destroyed

To generate an entity when the first entity is destroyed, use two Entity Generator blocks and a Simulink Function block. The Entity Terminator block calls the Simulink Function after destroying the first entity.

To open the example, see [Event-Based Entity Generation](#).

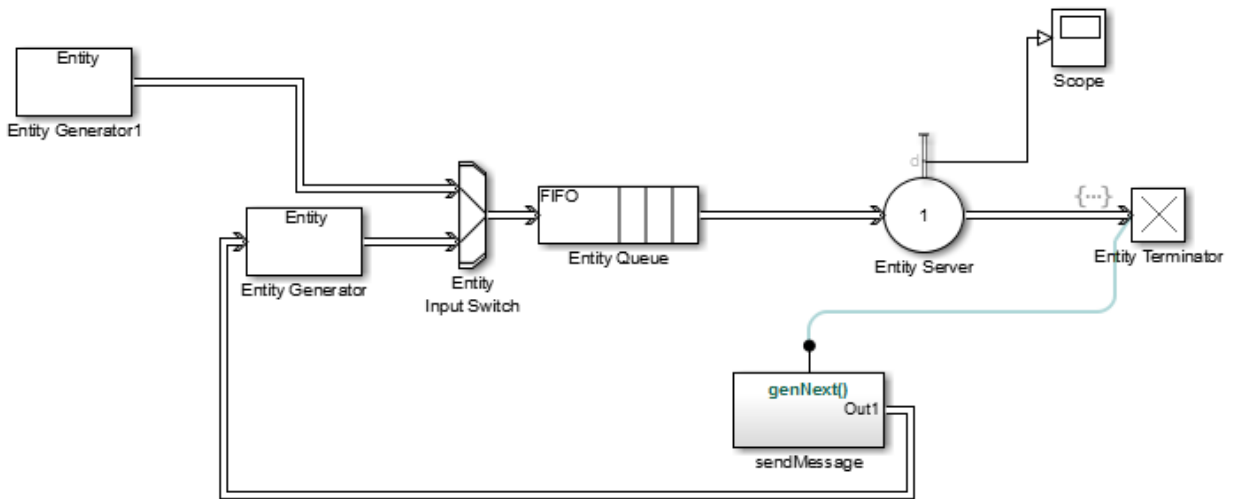

In this example, Entity Generator1 generates the first entity. SendMessage contains the genNext function, which sends a message.

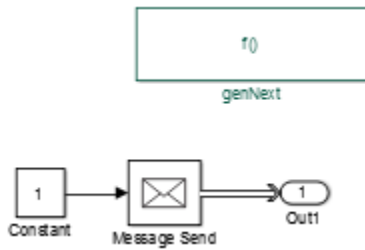

The Entity Terminator block calls the genNext function.

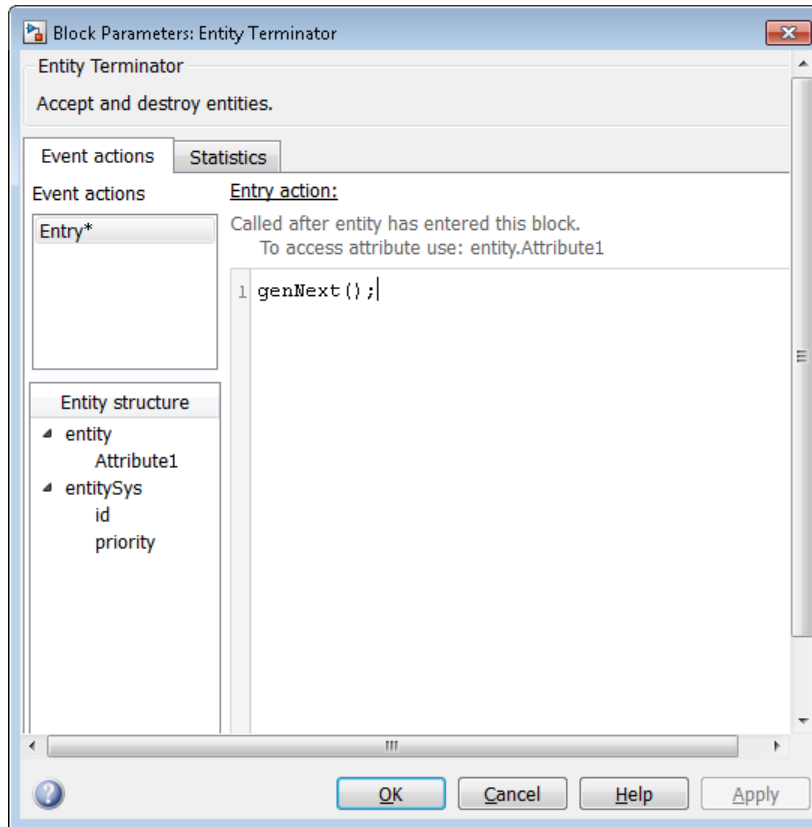

Generate Event-Based Entities Using Data Sets

For an example that uses an Excel® spreadsheet, see [Generating and Initializing Entities](#).

See Also

[Composite Entity Creator](#) | [Composite Entity Splitter](#) | [Discrete Event Chart](#) | [Entity Gate](#) | [Entity Generator](#) | [Entity Input Switch](#) | [Entity Multicast](#) | [Entity Output Switch](#) | [Entity Queue](#) | [Entity Replicator](#) | [Entity Server](#) | [Entity Terminator](#) | [MATLAB Discrete Event System](#) | [Multicast Receive Queue](#) | [Resource Acquirer](#) | [Resource Pool](#) | [Resource Releaser](#)

Related Examples

- “Specify Intergeneration Times for Entities” on page 1-16
- “Manipulate Entity Attributes” on page 1-40
- “Inspect Structures of Entities” on page 1-44
- “Generate Multiple Entities at Time Zero” on page 1-23
- “Count Simultaneous Departures from a Server” on page 1-30
- “Model Resource Allocation Using Composite Entity Creator block” on page 1-53
- “Replicate Entities on Multiple Paths” on page 1-54

More About

- “Entities in a SimEvents Model”
- “Role of Entity Ports and Paths”
- “Attribute Value Support” on page 1-61

Specify Intergeneration Times for Entities

The intergeneration time is the time interval between successive entities that the block generates. You can have a generation process that is:

- Periodic
- Sampled from a random distribution or time-based signal
- From custom code

For example, if the block generates entities at $T = 50$, $T = 53$, $T = 60$, and $T = 60.1$, the corresponding intergeneration times are 3, 7, and 0.1. After each new entity departs, the block determines the intergeneration time that represents the interval until the block generates the next entity.

Determine Intergeneration Time

You configure the Entity Generator block by indicating criteria that it uses to determine intergeneration times for the entities it creates. You can generate entities:

- From random distribution
- Periodically
- At arbitrary times

Use the dropdown list in the **Time source** parameter of the Entity Generation block to determine intergeneration times:

- **Dialog**

Uses the **Period** parameter to periodically vary the intergeneration times.

- **Signal port**

Uses a signal from an external block, such as the Sine wave block, to vary the intergeneration times.

- **MATLAB action**

Enables an **Intergeneration time action** field, in which you enter MATLAB code to customize the intergeneration times.

Periodically Vary the Intergeneration Times

- 1 In a new model, from the SimEvents library, drag the Entity Generator, Entity Terminator, and Scope blocks.
- 2 In the **Entity Generation** tab of the Entity Generator, set the **Time source** parameter to **Dialog**.
- 3 In the **Statistics** tab of the Entity Terminator block, select the **Number of entities arrived** check box.
- 4 Connect these blocks and simulate the model. The period is 1.

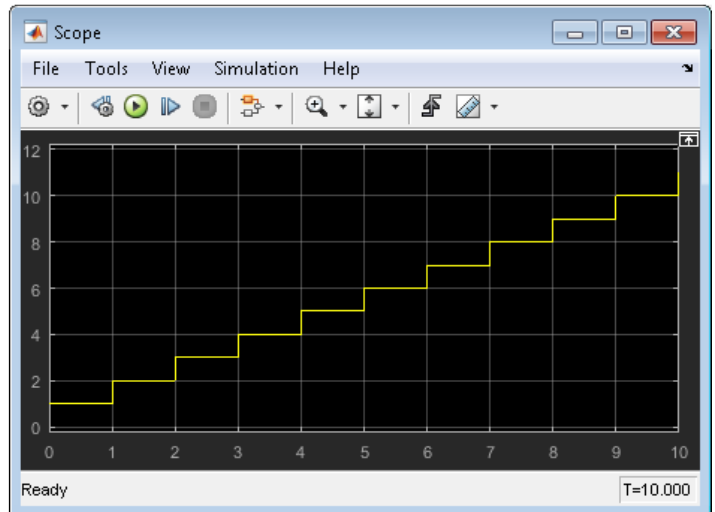
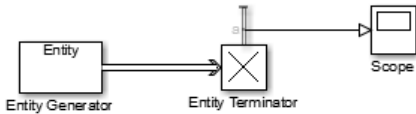

- 5 Vary the period to 8 and simulate the model again. Observe the change in the scope.

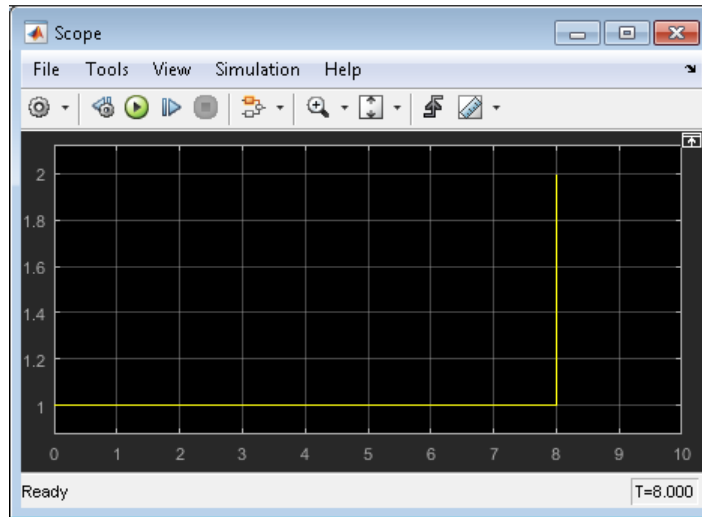

Use a Signal to Vary the Intergeneration Times

- 1 In a new model, from the SimEvents library, drag the Entity Generator and Entity Terminator blocks. From the Simulink library add the Sine Wave, and Scope blocks.
- 2 In the **Entity Generation** tab of the Entity Generator, set the **Time source** parameter to **Signal** port.

A new signal port appears on the Entity Generator block.

- 3 In the **Statistics** tab of the Entity Terminator block, select the **Number of entities arrived** check box.
- 4 Double-click the Sine Wave block. By default, the first value of the Sine Wave block is 0. To add a constant value to the sine to produce the output of this block, change the **Bias** parameter to another value, for example, 1.5.
- 5 Connect these blocks and simulate the model.

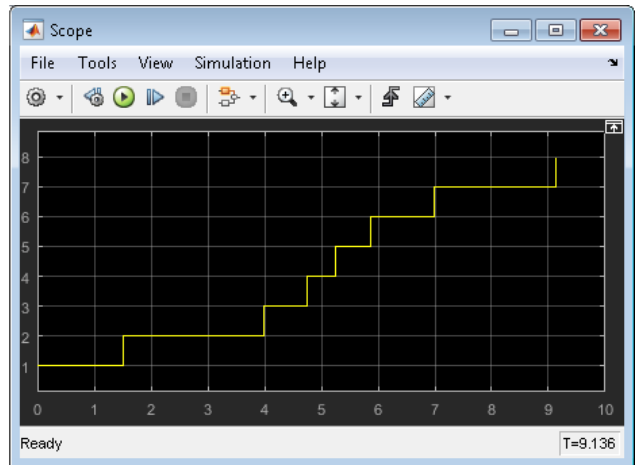
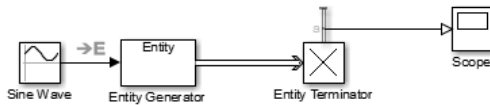

Upon generating each entity, the Entity Generator block reads the value of the input signal and uses that value as the time interval until the next entity generation.

Notice the capital **E** on the signal line from the Sine Wave block to the **Entity Generator** block. This icon indicates the transition from a time-based system to a discrete-event system.

Customize the Variation of the Intergeneration Times

- 1 In a new model, from the SimEvents library, drag the Entity Generator, Entity Terminator, and Scope blocks.
- 2 In the **Entity Generation** tab of the Entity Generator, set the **Time source** parameter to **MATLAB action**.

A new **Intergeneration time action** field appears on the Entity Generator block.

- 3 To customize the intergeneration times for your model, in the **Intergeneration time action** field, enter MATLAB code, for example:

```
dt = rand();
```

Note For intergeneration times, you must set the fixed name, *dt*. You cannot set any other variable name for this value.

- 4 In the Statistics tab of the Entity Terminator block, select the **Number of entities arrived** check box.

5 Connect these blocks and simulate the model.

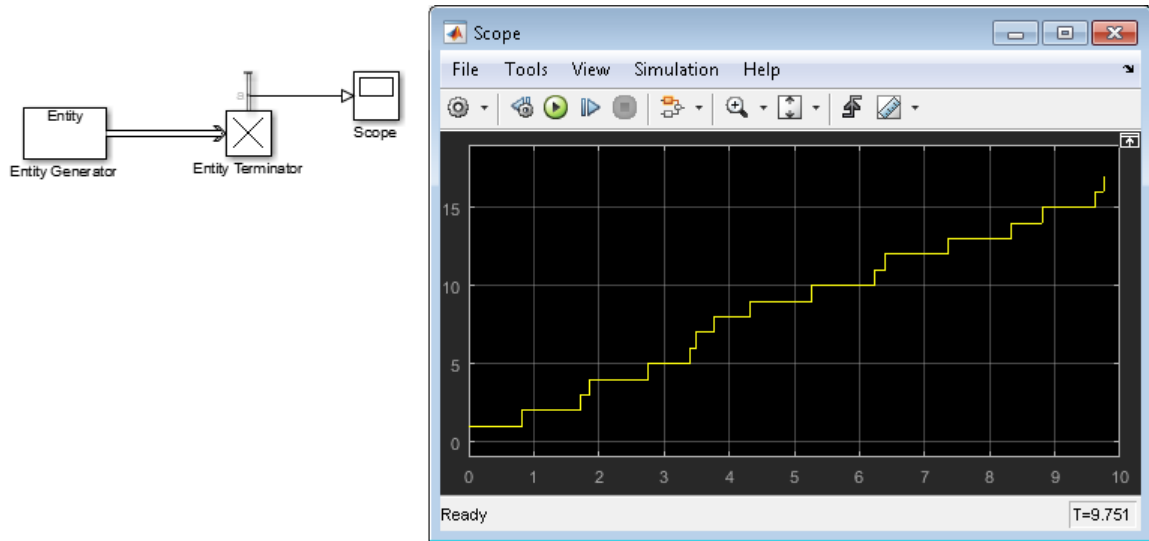

To generate entities with exponential random arrival times, in the **Intergeneration time action** field, enter MATLAB code that uses the mean function, for example:

```
mean = 1;  
dt = -mean*log(1-rand());
```

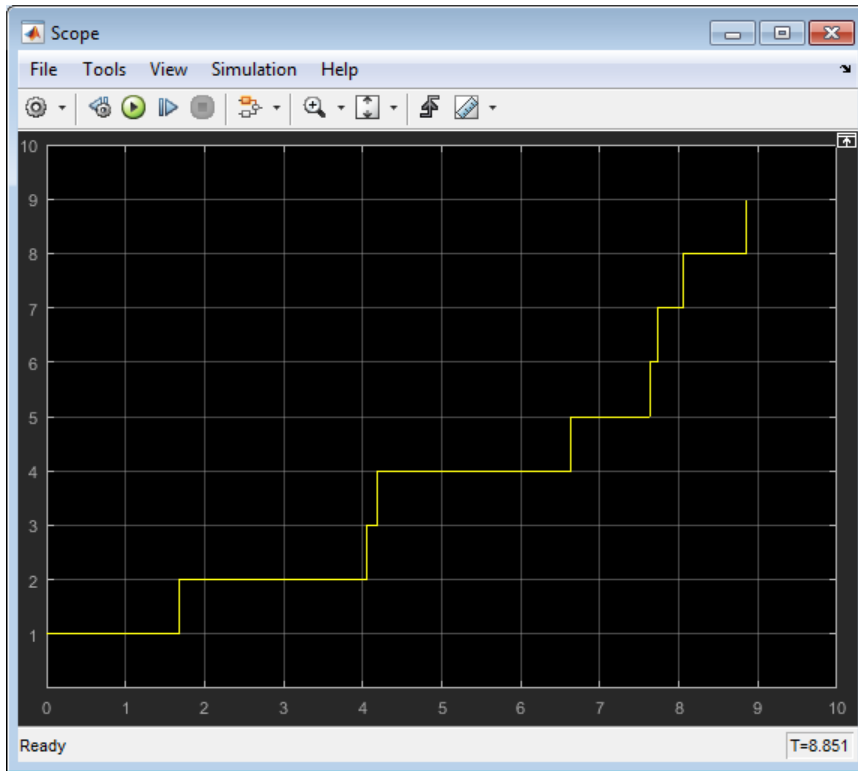

See Also

[Discrete Event Chart](#) | [Entity Server](#) | [Entity Generator](#) | [Entity Queue](#) | [Entity Replicator](#) | [Entity Terminator](#) | [MATLAB Discrete Event System](#)

Related Examples

- “Generate Entities When Events Occur” on page 1-12
- “Manipulate Entity Attributes” on page 1-40
- “Inspect Structures of Entities” on page 1-44
- “Generate Multiple Entities at Time Zero” on page 1-23
- “Count Simultaneous Departures from a Server” on page 1-30

- “Model Resource Allocation Using Composite Entity Creator block” on page 1-53
- “Replicate Entities on Multiple Paths” on page 1-54

More About

- “Entities in a SimEvents Model”
- “Role of Entity Ports and Paths”
- “Attribute Value Support” on page 1-61

Generate Multiple Entities at Time Zero

In a discrete-event simulation, an event is an observation of an instantaneous incident that may change a state variable, an output, and/or the occurrence of other events.

Suppose that you want to:

- Preload a queue or server with entities at the start of the simulation, before you analyze queuing or processing delays.
- Initialize the capacity of a shared resource before you analyze resource allocation behavior.

These scenarios requires multiple entity generation at the simulation start.

In these scenarios, you can simultaneously generate multiple entities at the start of the simulation. You can then observe the behavior of only those entities for the remainder of the simulation.

Build the model

To generate multiple entities at time 0, use MATLAB code in the Entity Generator block.

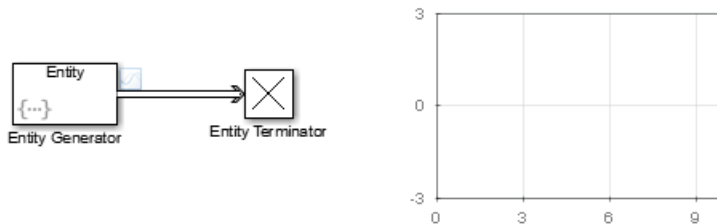

To open the example model without performing the configuration steps, see [A Simple Example of Generating Multiple Entities](#).

- 1 In a new model, from the SimEvents library, drag the Entity Generator, Entity Terminator, and Dashboard Scope blocks.
- 2 Double-click the Entity Generator block.
- 3 From the **Time source** drop-down list, select **MATLAB** action.

- 4 In the **Intergeneration time action** field, use MATLAB code to enter the number of entities that you want to generate. For example, you could use 8. In that case, at simulation time 0, the Entity Generator block generates 8 simultaneous events.

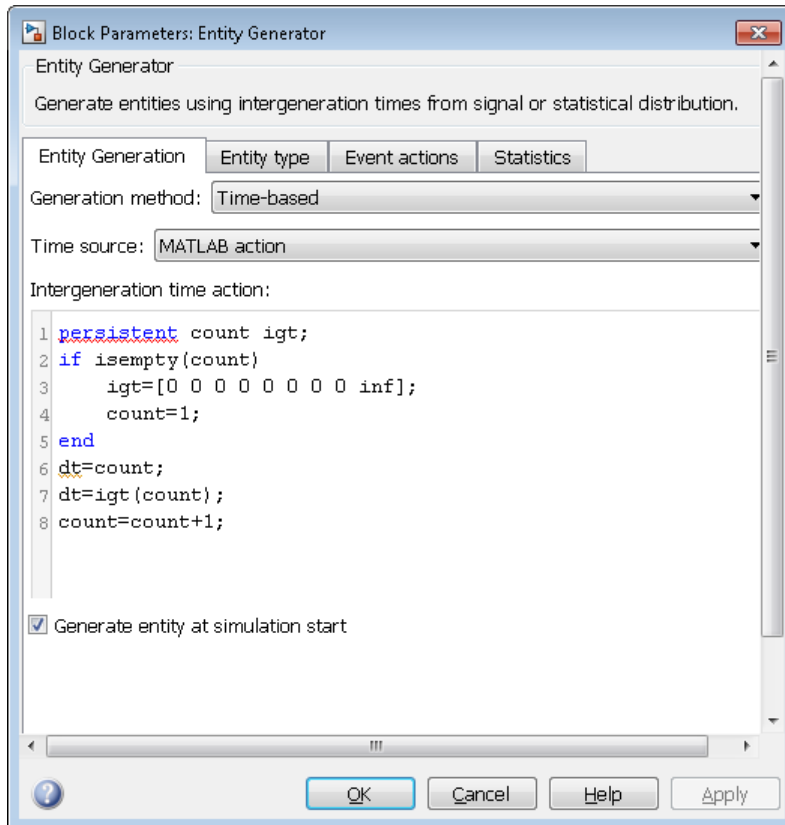

- 5 In the **Events action** tab, randomize the entity attribute. Select the **Generate** event action and, in the **Generate action** field, enter the MATLAB code:

```
entity.Attribute1=rand();
```

The output of the Dashboard Scope block shows that the software generates multiple entities at time 0.

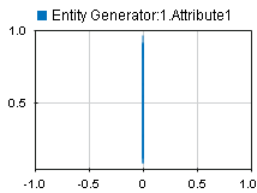

See Also

[Entity Generator](#) | [Entity Queue](#) | [Entity Server](#) | [Entity Terminator](#)

Related Examples

- “Generate Entities When Events Occur” on page 1-12
- “Specify Intergeneration Times for Entities” on page 1-16
- “Manipulate Entity Attributes” on page 1-40
- “Inspect Structures of Entities” on page 1-44
- “Count Simultaneous Departures from a Server” on page 1-30

More About

- “Entities in a SimEvents Model”

Adjust Entity Generation Times Through Feedback

This example shows a queuing system in which feedback influences the arrival rate. The goal of the feedback loop is to stabilize the entity queue by slowing the entity generation rate of the Entity Generator block as more entities accumulate in the Entity Queue block and the Entity Server block.

The diagram shows a simple queuing system with an Entity Generator, an Entity Queue, an Entity Server, and an Entity Terminator block. For more information about building this simple queuing system, see “Create a Discrete-Event Model”.

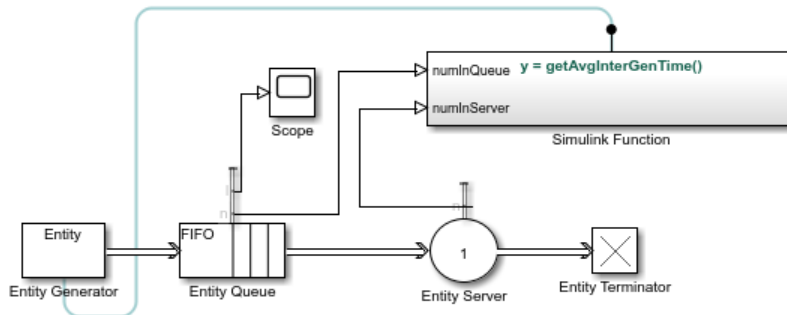

The capacity of the Entity Server block is 1. This causes an increase in the queue length without feedback. The goal is to regulate entity intergeneration time based on the size of the queue and the number of entities waiting to be served.

To open the example, see Example Model for Discouraged Arrival.

- 1 In the Entity Generator block, select MATLAB action as the **Time source**. Add this code to the **Intergeneration time action** field.

```
persistent rngInit;

if isempty(rngInit)
    seed = 12345;
    rng(seed);
    rngInit = true;
end

% Pattern: Exponential distribution
mu = getAvgInterGenTime();
dt = -mu*log(1-rand());
```

The entity intergeneration time dt is generated from an exponential distribution with mean μ , which is determined by the function `getAvgInterGenTime()`.

- 2 In the Entity Queue block, in the **Statistics** tab, select the **Number of entities in block, n**, and **Average queue length, l** as output statistics.
- 3 In the Entity Server block, select MATLAB action as the **Service time source**. Add this code to the **Service time action** field.

```
persistent rngInit;
if isempty(rngInit)
    seed = 67868;
    rng(seed);
    rngInit = true;
end

% Pattern: Exponential distribution
mu = 3;
dt = -mu*log(1-rand());
```

The service time dt is drawn from an exponential distribution with mean 3.

- 4 In the Entity Server block, in the **Statistics** tab, select the **Number of entities in block, n**, as output statistics.
- 5 Add a Simulink Function block from the SimEvents library. On the Simulink Function block, double-click the function signature and enter `y = getAvgInterGenTime()`.
- 6 In the Simulink Function block:
 - a

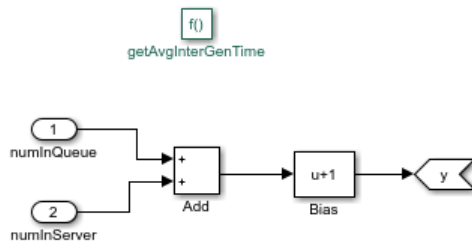

- a Add two In1 blocks and rename them as `numInQueue` and `numInServer`.

`numInQueue` represents the current number of entities accumulated in the queue and `numInServer` represents the current number of entities accumulated in the server.

- b** Add a Simulink Add block to add these two inputs.
- c** Add a Simulink Bias block and set the **Bias** parameter as 1.

The constant bias 1 is to guarantee a nonzero intergeneration time.

Optionally, select **Display > Function Connections** from the main menu to display the feedback loop from the Simulink Function block to the Entity Generation block.

- 7** In the parent model, connect the **Number of entities in block, n** statistics from the Entity Queue and Entity Server blocks to the Simulink Function block.
- 8** Connect a Simulink Scope block to the **Average queue length, l** statistic from the Entity Queue block.

The goal is to investigate the average queue length.

- 9** Increase the simulation time to 10000 and simulate the model.
- 10** Observe that the **Average queue length, l** in the scope is nonincreasing due to the effect of feedback for the discouraged entity generation rate.

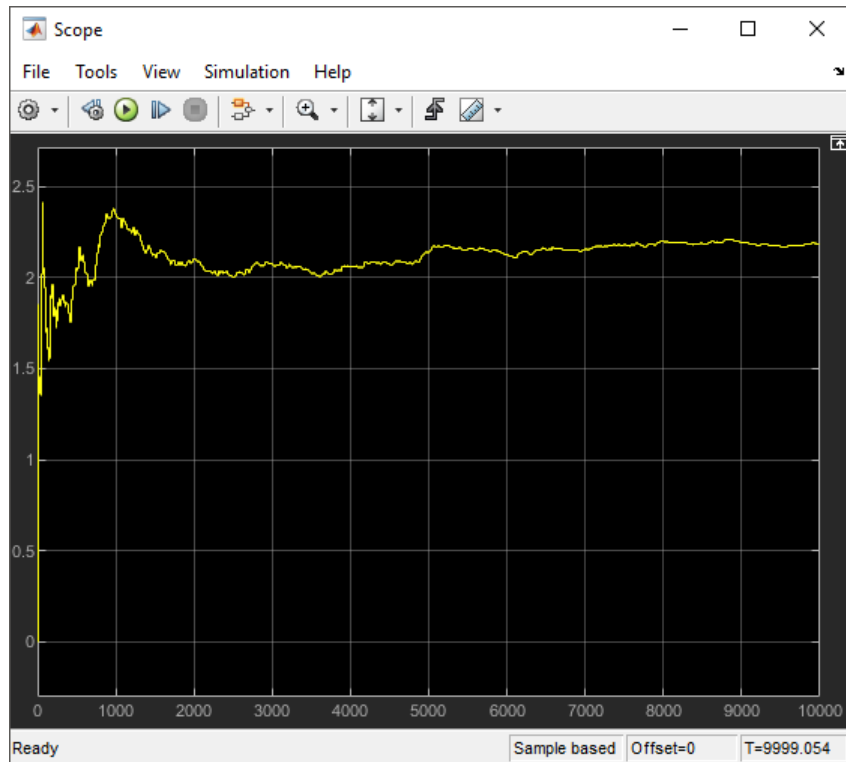

See Also

[Entity Generator](#) | [Entity Queue](#) | [Entity Server](#) | [Entity Terminator](#)

Related Examples

- “Generate Entities When Events Occur” on page 1-12
- “Generate Multiple Entities at Time Zero” on page 1-23
- “Count Simultaneous Departures from a Server” on page 1-30
- “Replicate Entities on Multiple Paths” on page 1-54

Count Simultaneous Departures from a Server

This example shows how to count the simultaneous departures of entities from a server. Use the **d** output from the Entity Server block to learn how many entities have departed (or arrived at) the block. The output signal also indicates when departures occurred. This method of counting is cumulative throughout the simulation.

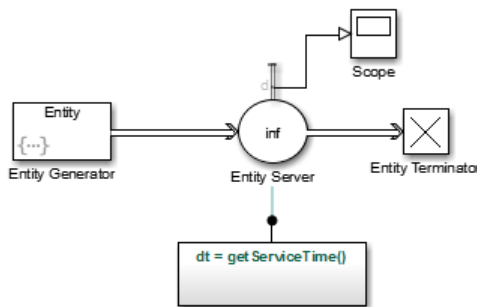

To open the example, see [Count Simultaneous Departures](#).

- 1 In a new model, from the SimEvents library, drag the Entity Generator, Entity Server, Entity Terminator, and Simulink Function blocks. Add a Simulink Scope block.
- 2 Double-click the Entity Generator block.
 - In the **Event actions** tab, to generate random attribute values, enter:

```
entity.Attribute1=rand();
```
- 3 Double-click the Entity Server block. In the **Main** tab:
 - In the **Capacity** parameter, enter `inf`.
 - For the **Service time** parameter, select **MATLAB** action.
 - In the **Service time action** parameter, enter:

```
dt = getServiceTime();
```
 - In the **Statistics** tab, select **Number of entities departed, d**.
- 4 In the Simulink Function block, add a Repeating Sequence Stair and define the `getServiceTime` function.

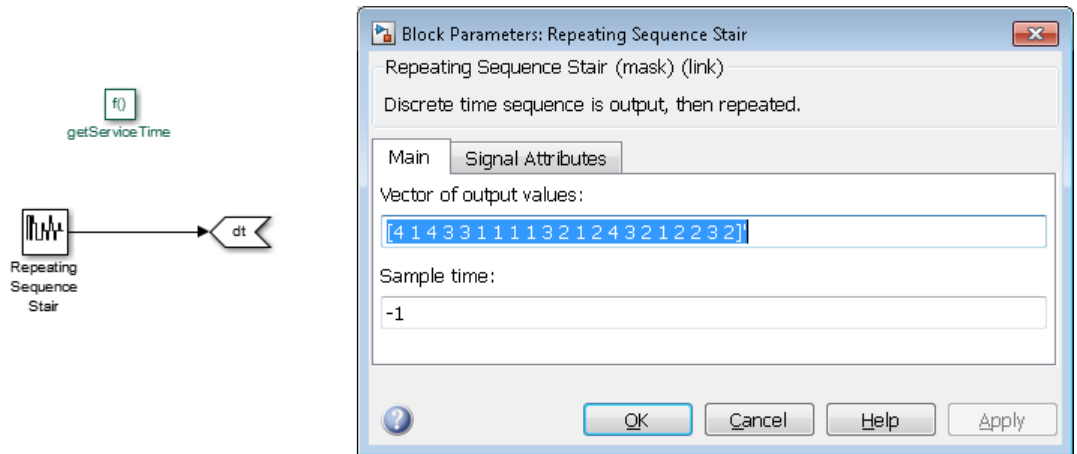

- 5 Connect the blocks as shown and simulate the model. Observe that the scope displays simultaneous entity departures for the corresponding time.

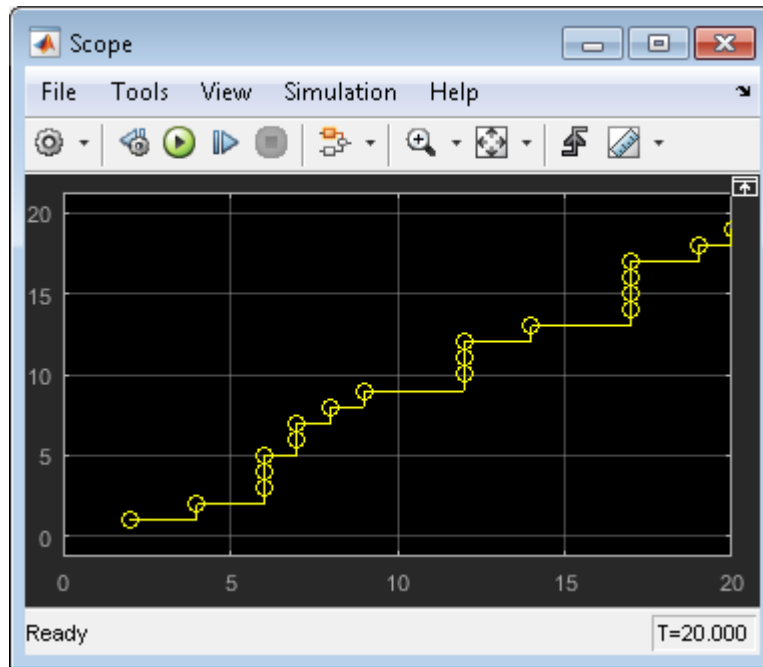

See Also

Composite Entity Creator | Entity Gate | Entity Generator | Entity Multicast | Entity Queue | Entity Server | Entity Terminator | Resource Acquirer

Related Examples

- “Generate Entities When Events Occur” on page 1-12
- “Specify Intergeneration Times for Entities” on page 1-16
- “Manipulate Entity Attributes” on page 1-40
- “Generate Multiple Entities at Time Zero” on page 1-23
- “Replicate Entities on Multiple Paths” on page 1-54

More About

- “Entities in a SimEvents Model”

Noncumulative Counting of Entities

This example shows how to count entities, which arrive to an Entity Terminator block, in a noncumulative way by resetting the counter at each time instant.

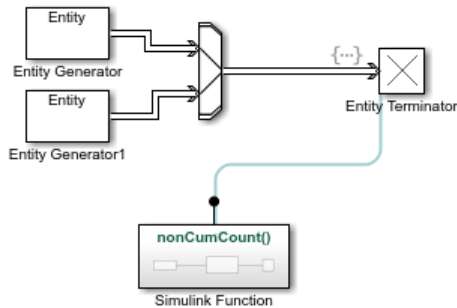

To open the example, see Example Model for Noncumulative Entity Count.

- 1 Add two Entity Generator blocks, an Entity Input Switch block, an Entity Terminator block, and a Simulink Function block from the SimEvents library to a new model. For more information, see Simulink Function.
- 2 Connect the blocks as shown in the diagram.
- 3 Double-click the Entity Generator1 block. In the **Entity generation** tab, set the **Period** to 2.

In the model, 2 entities arrive to Entity Terminator block at time 0, 2, 4, 6, 8, 10 and 1 entity arrives at time 1, 3, 5, 7, 9.

- 4 Double-click the function signature on the Simulink Function block and enter `nonCumCount()`.

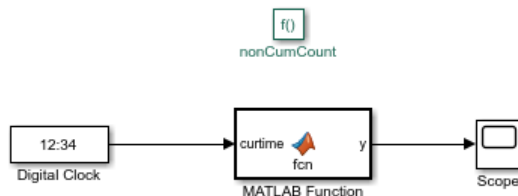

- 5 Double-click the Simulink Function block. Add a Digital Clock block from the **Simulink > Sources** library. Set the **Sample time** parameter to -1 for inherited sample time.

- 6 Add a MATLAB Function block. Double-click it and enter this code.

```
function y = fcn(curtime)
% Define count for counting and prevtime for previous time stamp
persistent count prevtime;
% Check if prevtime is empty and initiate the count
if isempty(prevtime)
    prevtime = curtime;
    count = 0;
end
% Increase count by 1 for equal time stamps.
if isequal(curtime, prevtime)
    count = count + 1;
% Reset count to 1 if two consecutive time stamps are not identical
else
    prevtime = curtime;
    count = 1;
end
% Output count for visualization
y = count;
end
```

Save the file (optional).

- 7 Connect the output of the MATLAB Function block to a Simulink Scope block.
- 8 In the parent model, double-click the Entity Terminator block. In the **Entry action** field of the **Event actions** tab, enter this code.

```
nonCumCount();
```

- 9 Simulate the model and open the Scope block in the Simulink Function block.
- 10 Change the plotting settings of the Scope block by right-clicking the plot and selecting **Style**. Select no line for the **Line** and circle for the **Marker** parameters.
- 11 Observe that the block illustrates the noncumulative entity count for the entities arriving the Entity Terminator block. The block also illustrates the instantaneous entity arrivals at each time.

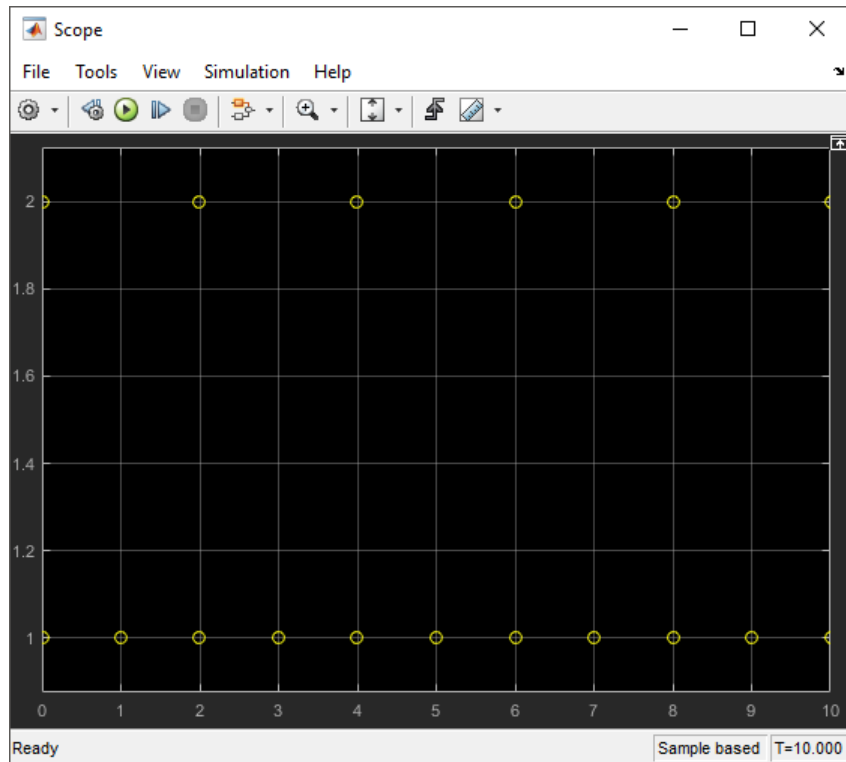

To count the number of events that occur instantaneously, use `nonCumCount()` in any **Event actions**.

See Also

Entity Gate | Entity Generator | Entity Input Switch | Entity Terminator

Related Examples

- “Count Simultaneous Departures from a Server” on page 1-30
- “Generate Entities When Events Occur” on page 1-12
- “Specify Intergeneration Times for Entities” on page 1-16
- “Generate Multiple Entities at Time Zero” on page 1-23

More About

- “Entities in a SimEvents Model”
- “Role of Entity Ports and Paths”
- “Attribute Value Support” on page 1-61

Working with Entity Attributes

In this section...

“Attach Attributes” on page 1-37

“Set Attributes” on page 1-37

You can attach data to an entity using one or more attributes of the entity. Each attribute has a name and a numeric value. You can read or change the values of attributes during the simulation.

For example, suppose your entities represent a message that you are transmitting across a communication network. You can attach the length of each particular message to the message itself using an attribute named `length`.

You can also use attributes to specify the amount of a resource for your model. For more information, see “Model Using Resources” on page 4-2.

Attach Attributes

To attach attributes to an entity, use the Entity Generator block. Attribute attachments can create new attributes or change the values of existing attributes. You can attach attributes such as:

- Constant value
- Random numbers
- Elements of either a vector in the MATLAB workspace or a vector that you can type in a block dialog box
- Values of an output argument of a MATLAB function that you write
- Values of a signal
- Outputs of a function defined in Simulink or Stateflow® environment that you write.



Set Attributes

To build and manage the list of attributes to attach to each departing entity, use the controls under the **Define attributes** section of the Entity Generator block. Each attribute appears as a row in a table.

Using these controls, you can:

- Add an attribute manually to attach to the entity.
- Modify an attribute that you added to the table from the **Available Attributes** list to attach to the entity.

The buttons under **Set Attribute** perform these actions.

Button	Action	Notes
	Add a template attribute to the table.	Rename the attribute and specify its properties.
	Remove the selected attribute from the attribute table.	When you delete an attribute this way, no confirmation appears and you cannot undo the operation.

The table displays the attributes you added manually. Use it to set these attribute properties.

Property	Specify	Use
Attribute Name	The name of the attribute. Each attribute must have a unique name.	Double-click the existing name, and then type the new name.
Attribute Initial Value	The value to assign to the attribute (when the attribute comes from the dialog box).	Double-click the value, and then type the value you want to assign.

See Also

Discrete Event Chart | Entity Generator | MATLAB Discrete Event System

Related Examples

- “Manipulate Entity Attributes” on page 1-40

More About

- “Entities in a SimEvents Model”
- “Attribute Value Support” on page 1-61
- “Model Resource Allocation Using Composite Entity Creator block” on page 1-53

Manipulate Entity Attributes

The attributes table describes some ways that you can use data that you have attached to an entity.

- Create a signal
- Create a plot
- Compute a different attribute value
- Help specify behavior of a block that supports the use of attribute values for block parameters. Examples are the service time for a server and the selected port for an output switch.

Suppose that your entity possesses an attribute with one of these quantities:

- Service time to be used by a downstream server block
- Switching criterion to be used by a downstream switch block

When an entity with one of these attribute quantities arrives at a server or switch block, you can directly reference the attribute using an option on the server or switch block dialog box.

Write Functions to Manipulate Attributes

To manipulate attributes using code, use the **Event actions** tab of a block. In this tab, you can write MATLAB code to manipulate the attribute. To access the attribute, use the notation *entityName.attributeName*. For example:

```
entity.Attribute1=5;
```

For example, you might want to manipulate the attributes for service completion.

- 1 In a new model, from the SimEvents library, drag the Entity Generator, Entity Server, and Entity Terminator blocks and connect them.

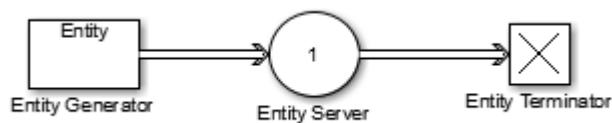

- 2 Double-click Entity Generator and, in the **Entity type** tab, add three attributes to the attributes table.

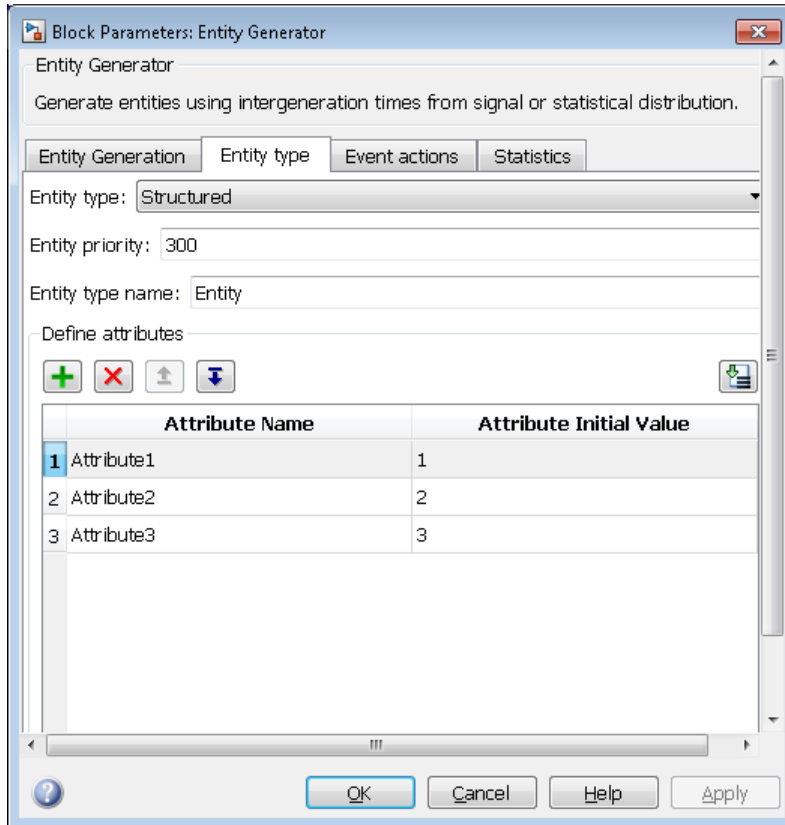

- 3 In the Entity Server block, click the **Event actions** tab.
- 4 For the **Service complete** action, enter MATLAB code to manipulate the entity attributes you added in the Entity Generator block. For example:

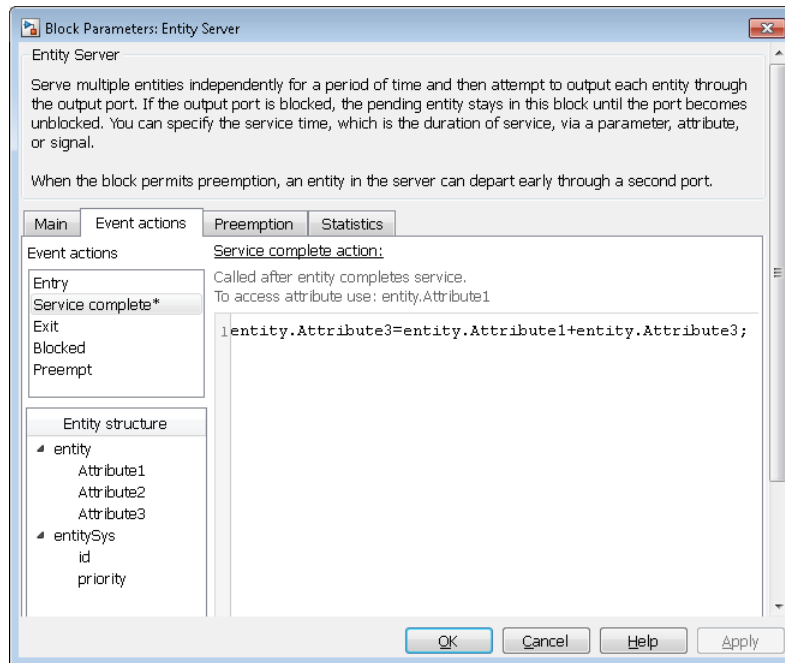

This code updates the Entity Server block with the event action icon.

- 5 To see the action, in the model, hover over the Entity Server block event action icon block.

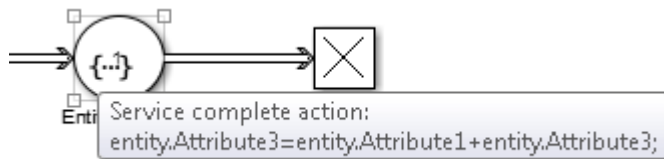

See Also

Discrete Event Chart | Entity Generator | MATLAB Discrete Event System

Related Examples

- “Manipulate Entity Attributes” on page 1-40

More About

- “Entities in a SimEvents Model”
- “Working with Entity Attributes” on page 1-37
- “Attribute Value Support” on page 1-61

Inspect Structures of Entities

You can inspect entity structures using these methods:

- On a signal line, using the Signal Hierarchy Viewer (for more information, see “Display Entity Types” on page 1-44).
- In a block at run-time, using the Storage Inspector

Display Entity Types

To show entity types in your model, in the model editor, right-click a line and select **Signal Hierarchy**. The Signal Hierarchy Viewer interactively displays about entities, signals, and bus objects. For more information on the Signal Hierarchy Viewer, see “Signal Hierarchy Viewer” (Simulink).

If you have configured any blocks to receive an entity structure that the preceding block does not provide, upon compilation, the software automatically displays entity types. This behavior helps you to troubleshoot the mismatch in entity structures before simulation. The software displays an approximate list of the entity types and attributes. Use this as a guideline and not as a definitive list.

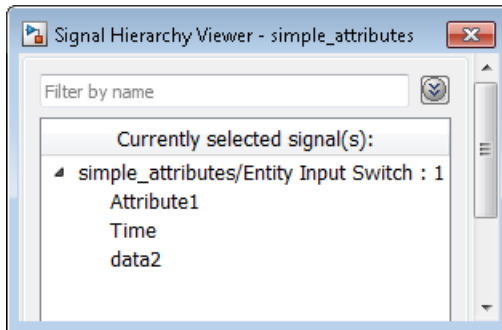

If entities on two separate paths have the same structure throughout the model, you can use the same entity type for both entity paths.

If you now modify the second Entity Generate block path to change `data2` to `data3`, the structure of entities on the second path becomes unique. You must specify a new entity type name for the second Entity Generator block.

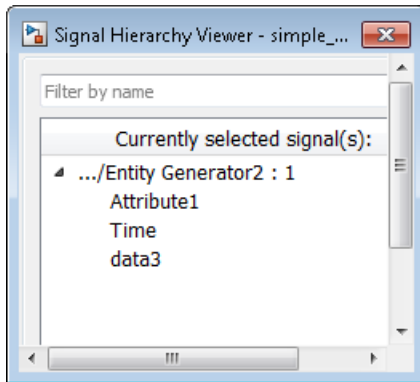

Inspect Entities at Run Time

To inspect entities at run-time, use the Storage Inspector. Inspect entities, batched entities, and their attribute values in a block.

- 1 In a SimEvents model, use the Simulink Simulation Stepper to step through the model.
- 2 As you step through the model, each block with entities updates to contain a magnifying glass.
- 3 To display entity details, including attributes, click the magnifying glass.

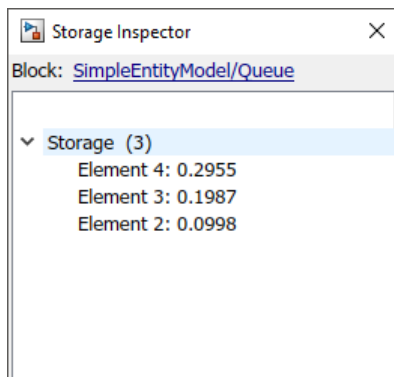

- 4 To see the number of entities, hover over the magnifying glass.

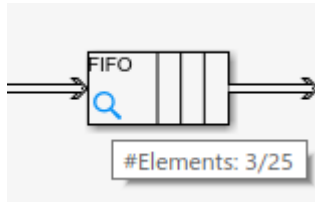

Alternatively, use the SimEvents Debugger to inspect entities. For more information, see [SimEvents Debugger](#).

See Also

[Entity Generator](#) | [SimEvents Debugger](#)

More About

- “Entities in a SimEvents Model”
- “Role of Entity Ports and Paths”
- “Attribute Value Support” on page 1-61

Generate Entities Carrying Nested Data Structures

This example shows how to investigate the throughput of a vehicle service facility using Simulink Bus Editor to create nested data structures carried by entities.

The facility has three service stations represented by three Entity Server blocks. The vehicles arriving at the facility are queued and then directed to one of the three service stations based on their size and mileage. It is assumed that the older vehicles require more service time.

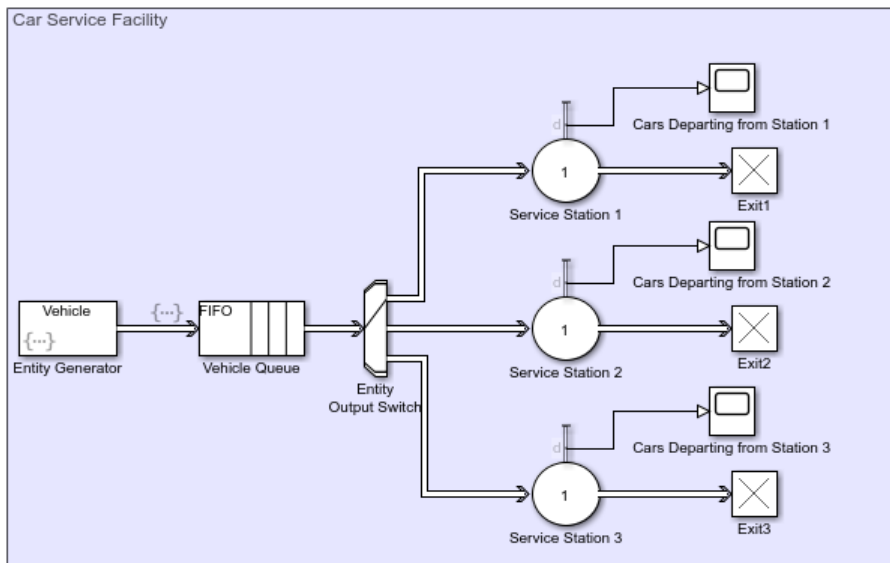

- 1 Create entities that represent vehicles arriving at a service facility. The entities carry data representing the vehicle dimensions and properties as nested bus objects. Vehicle dimensions include vehicle height and width in meters and vehicle properties include its age and current mileage. For more information about using the Bus Editor, see “Create and Specify Bus Objects” (Simulink).
 - a Under **Modeling** tab, in **Design** section, select and open the **Bus Editor**.
 - b In the Bus Editor, select **File > Add Bus**.
 - c Create a new bus object and set the **Name** property to **Dimensions**.
 - d Select **File > Add/Insert BusElement** to create two bus elements, **Height** and **Width**.

1 Working with Entities

- e Create another bus object and set the **Name** property to Properties. Add three bus elements Station, Year, and Mileage.
- f Create another bus object and set the **Name** property to Vehicle.
- g Add two bus elements and set their **Name** properties to VehicleDimensions and VehicleProperties. For their **Data type** properties, use the Bus : <object name> template, replacing <object name> with Dimensions and Properties.

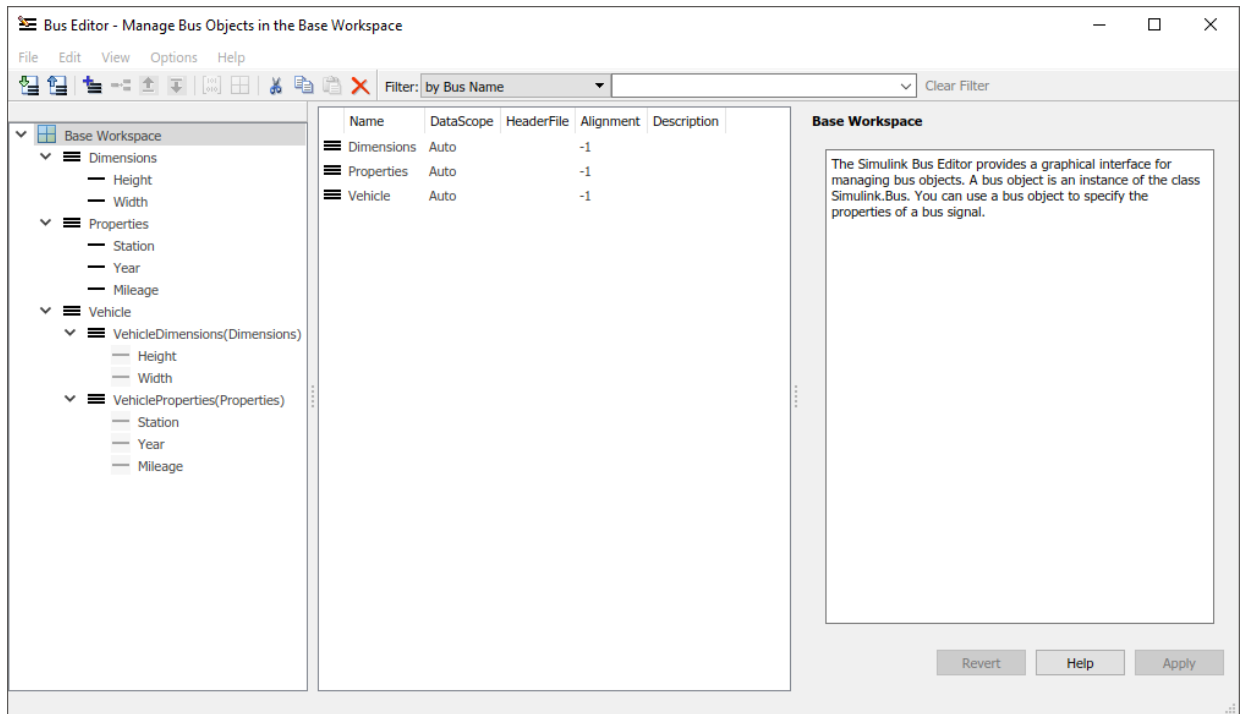

- 2 Add an Entity Generator block. Double-click the Entity Generator block.
 - a Select the **Entity type** tab. Set the **Entity type** to Bus object and **Entity type name** as Vehicle.

Vehicle is the bus object created by the Bus Editor.

- b Select the **Event actions** tab. In the **Generate action** field, enter:

```
% Vehicle Dimensions  
entity.VehicleDimensions.Height = 1+rand();
```

```
entity.VehicleDimensions.Width = 1+rand();
% Vehicle Properties
entity.VehicleProperties.Year = randi([1996 2018]);
entity.VehicleProperties.Mileage = randi([50000 150000]);
```

The vehicles arrive at the facility with random dimensions and properties.

- 3 Add an Entity Queue block and rename it Vehicle Queue.
 - a In the **Main** tab, set the **Capacity** to Inf.
 - b Select the **Event actions** tab. In the **Entry action** field, enter this code to specify service station selection for vehicles.

```
% If the height and width of the vehicle are greater than 1.5 m, select Station 1.
if entity.VehicleDimensions.Width > 1.5 && entity.VehicleDimensions.Height > 1.5
    entity.VehicleProperties.Station = 1;
% Else, if the vehicle's mileage is greater than 90000 km, select Station 2.
else if entity.VehicleProperties.Mileage > 90000
    entity.VehicleProperties.Station = 2;
% If the vehicle's mileage is less than 90000 km, select Station 3.
else
    entity.VehicleProperties.Station = 3;
end
end
```

The vehicles are queued to be directed to the correct service station and vehicle dimensions and properties are used to select the appropriate service station.

- 4 Add an Entity Output Switch block.
 - a Set the **Number of output ports** to 3.
 - b Set the **Switching criterion** to From attribute.
 - c Set the **Switch attribute name** to VehicleProperties.Station.

The Entity Output Switch block directs the vehicles to the stations based on the specified Station attribute.

- 5 Add an Entity Server block that represents the service station. Rename the block Service Station 1.

- a In the **Main** tab, set the **Service time source** to MATLAB action.
- b In the **Service time action** field, enter:

```
if entity.VehicleProperties.Year > 2015
    dt = 1;
else
    dt = 5;
end
```

It is assumed that the vehicle service time is longer for older vehicles.

- c In the **Statistics** tab, select **Number of entities departed**, **d** statistic and connect it to a scope.
- 6 Connect Service Station 1 to an Entity Terminator block.
- 7 Follow the same steps to create Service Station 2 and Service Station 3 and connect them as shown.
- 8 Increase the simulation time to 100 and run the simulation.

Observe the number of vehicles served at Service Station 1.

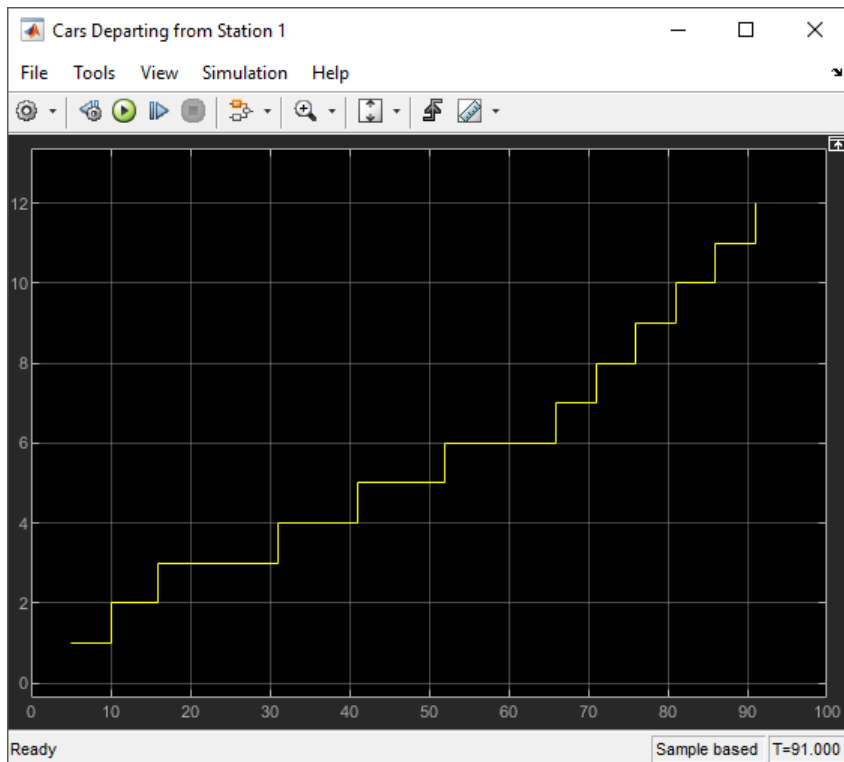

Observe the number of vehicles served at Service Station 2.

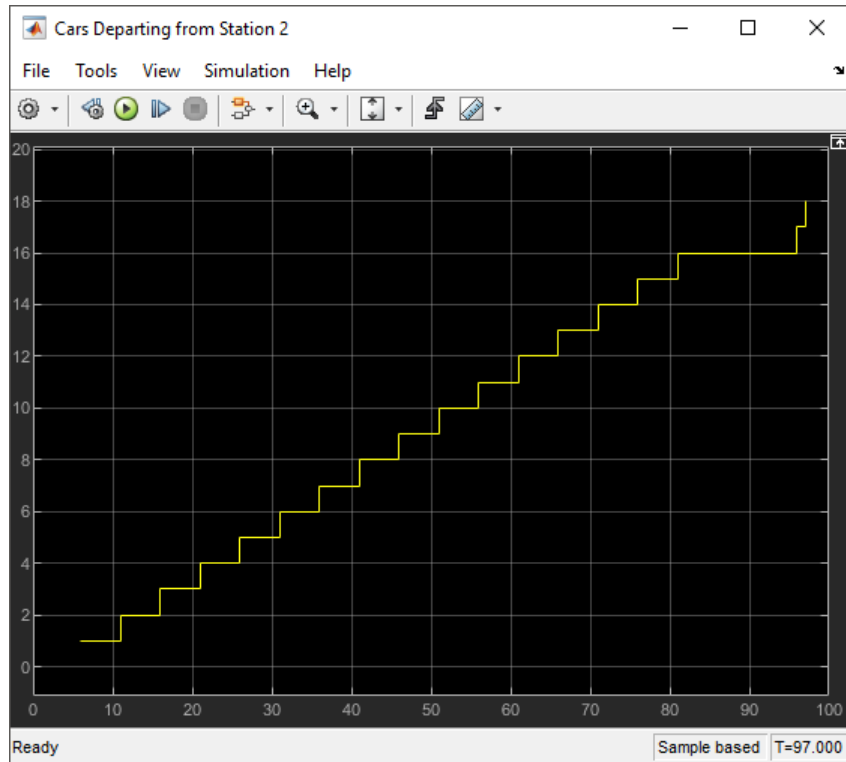

Observe the number of vehicles served at Service Station 3.

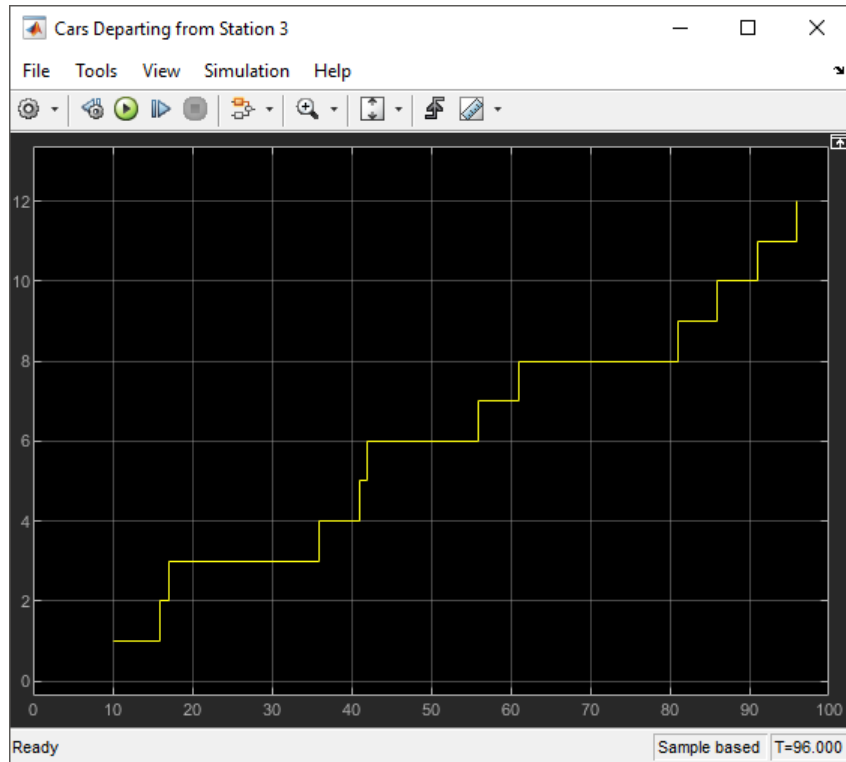

See Also

Entity Generator | Entity Output Switch | Entity Queue | Entity Server

More About

- "Entities in a SimEvents Model"
- "Adjust Entity Generation Times Through Feedback" on page 1-26
- "Generate Entities When Events Occur" on page 1-12
- "Inspect Structures of Entities" on page 1-44

Model Resource Allocation Using Composite Entity Creator block

The goal of this example is to show how to use Composite Entity Creator block for resource allocation. You can combine entities from different paths using the Composite Entity Creator block. The entities that you combine, called composite entities, might represent different parts within a larger item, such as the header, payload, and trailer that are parts of a data packet. Alternatively, you can model resource allocation by combining an entity that represents a resource with an entity that represents a part or other item.

The Composite Entity Creator block detects when all necessary component entities are present and when the composite entity that results from the combining operation will be able to advance to the next block. The Composite Entity Creator block provides options for managing information (attributes and timers) associated with the component entities. You can also configure the Composite Entity Creator block to make the combining operation reversible via the Composite Entity Splitter block.

See Also

[Composite Entity Creator](#) | [Composite Entity Splitter](#) | [Entity Generator](#)

More About

- [“Entities in a SimEvents Model”](#)

Replicate Entities on Multiple Paths

The Entity Replicator block enables you to distribute copies of an entity on multiple entity paths. Replicating entities might be a requirement of the situation you are modeling. For example, copies of messages in a multicasting communication system can advance to multiple transmitters or multiple recipients.

Similarly, copies of computer jobs can advance to multiple computers in a cluster so that the jobs can be processed in parallel on different platforms.

In some cases, replicating entities is a convenient modeling construct.

Modeling Notes

- Unlike the Entity Output Switch block, the Entity Replicator block has departures at all of its entity output ports that are not blocked, not just a single selected entity output port.
- If your model routes the replicates such that they use a common entity path, then be aware that blockages can occur during the replication process. For example, if you have this scenario:
 - An Entity Replicator block has the **Replicas depart from** parameter set to **Separate output ports**.
 - The block has these output ports connected to individual Entity Server blocks.

A blockage can occur because the servers can accommodate at most one of the replicates at a time. The blockage causes fewer than the maximum number of replicates to depart from the block.

- Each time the Entity Replicator block replicates an entity, the copies depart in a sequence whose start is determined by the **Hold original entity until all replicas depart** parameter. Although all copies depart at the same time instant, the sequence might be significant in some modeling situations. For details, see the reference page for the Entity Replicator block.

See Also

Entity Generator | Entity Replicator

More About

- “Entities in a SimEvents Model”

Measure Point-to-Point Delays

Determine how long each entity takes to advance from one block to another, or how much time each entity spends in a particular region of your model. To compute these durations, you can measure time durations on each entity that reaches a particular spot in the model. A general workflow is:

- 1 Create an attribute on the entity that can hold the time value.
- 2 When the entity reaches a particular point in the model, set the current value of time on the attribute. Call a Simulink function that contains a Digital Clock block.
- 3 When the entity reaches the destination, compute the time interval by passing the attribute value to another Simulink function that compares it to the current simulation time.

Basic Example Using Timer Blocks

This example lets you see if a FIFO order or prioritized queue for customers results in a shorter wait time. The `startTimer` and `readTimer` Simulink functions jointly perform the timing computation. This example uses the Mean block from the DSP System Toolbox™ to calculate average times.

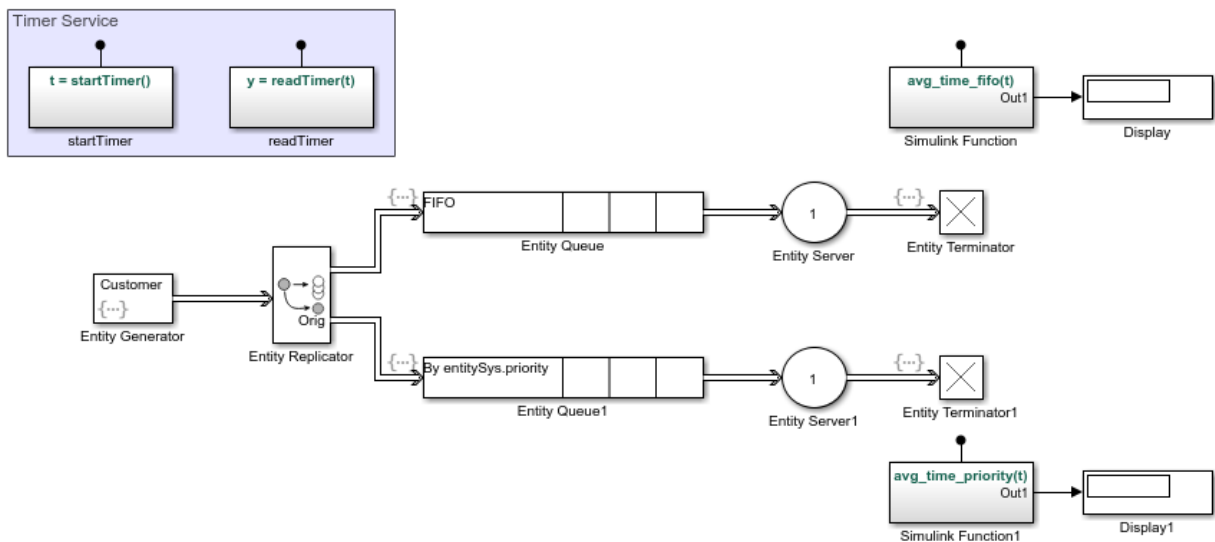

This example has four Simulink Function blocks. Two define timer functions, startTimer and readTimer. The other functions calculate average times.

- 1 In a new model, drag the blocks shown in the example and relabel and connect them as shown.
- 2 For the startTimer block, define:

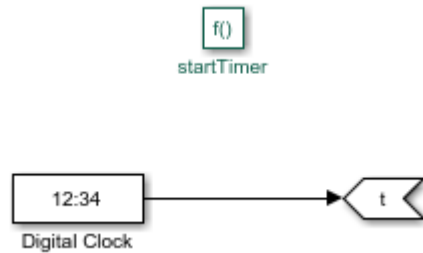

- 3 For the readTimer block, define:

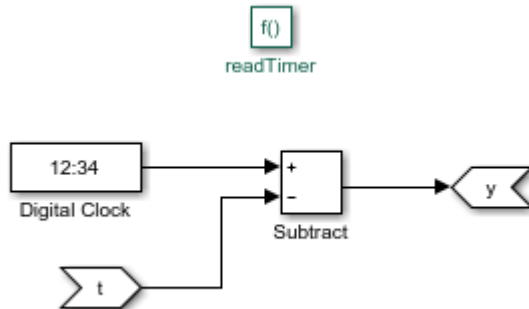

- 4 For the avg_time_fifo(t) and avg_time_priority Simulink Function blocks, insert a Mean block, for example:

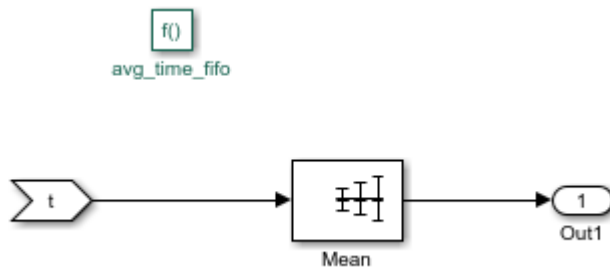

5 For the Entity Generator block:

a In the **Entity type** tab, add two attributes, `ServiceTime` and `Timer`.

b In the **Entity actions** tab, set the two attribute values:

```
entity.ServiceTime = exprnd(3);  
entitySys.priority = randi(2);
```

6 In Entity Queue:

a In the **Main** tab, set **Queue type** to FIFO.

b In the **Event actions** tab, call the `startTimer` function for the Entry action:

```
entity.Timer = startTimer();
```

7 In Entity Queue1:

a In the **Main** tab, configure the block to be a priority queue with a priority source of `entitySys.priority`:

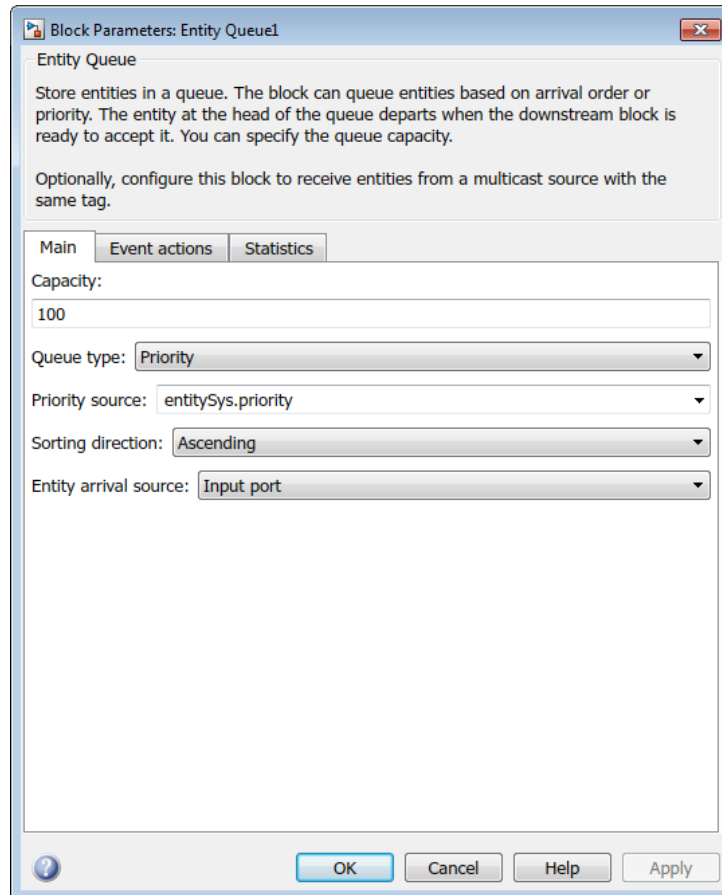

- b** In the **Event actions** tab, call the `startTimer` function for the Entry action:

```
entity.Timer = startTimer();
```
- 8** For both Entity Server blocks:
 - a** Set **Service time source** to Attribute.
 - b** Set **Service time attribute name** to ServiceTime.
- 9** For Entity Terminator, call the `readTimer` and `avg_time_fifo` functions for the Entry event:

```
% Read timer
elapsedTime = readTimer(entity.Timer);
```

```
% Compute average
avg_time_fifo(elapsedTime);
```

- 10 For Entity Terminator1, call the readTimer and avg_time_priority functions for Entry event:

```
% Read timer
elapsedTime = readTimer(entity.Timer);
```

```
% Compute average
avg_time_priority(elapsedTime);
```

- 11 Save and run the model.

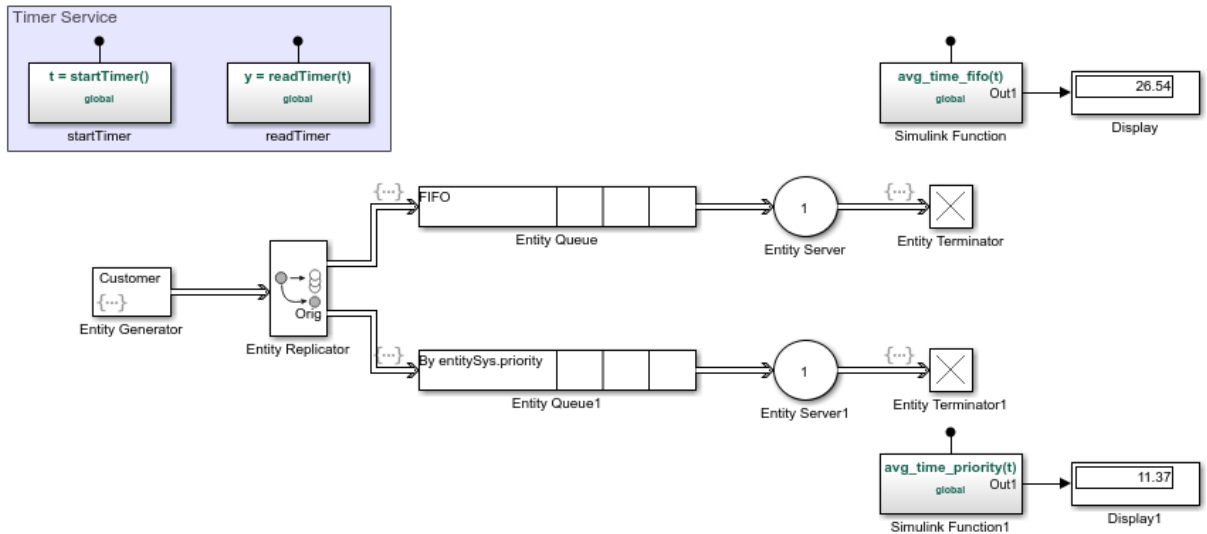

See Also

Entity Generator | Entity Replicator | Simulink Function

More About

- “Entities in a SimEvents Model”

Attribute Value Support

These lists summarize the characteristics of attribute values for structured entity types.

Permitted Characteristics of Attribute Values

- Real or complex
- Array of any dimension, where the dimensions remain fixed throughout the simulation
- All built-in data types (`double`, `single`, `int8`, `uint8`, `int16`, `uint16`, `int32`, and `uint32`)
- Enumerations

For a given attribute, the characteristics of the value must be consistent throughout the discrete-event system in the model.

Not Permitted as Attribute Values

- Structure
- Bus
- Variable-size signals or variable-size arrays
- Frame

See Also

Discrete Event Chart | Entity Generator | MATLAB Discrete Event System

Related Examples

- “Manipulate Entity Attributes” on page 1-40

More About

- “Entities in a SimEvents Model”
- “Working with Entity Attributes” on page 1-37

Modeling Queues and Servers

- “Model Basic Queuing Systems” on page 2-2
- “Sort by Priority” on page 2-6
- “Task Preemption in a Multitasking Processor” on page 2-9
- “Determine Whether a Queue Is Nonempty” on page 2-12
- “Model Server Failure” on page 2-13

Model Basic Queuing Systems

In this section...
“Example of a Logical Queue” on page 2-2
“Vary the Service Time of a Server” on page 2-2

Example of a Logical Queue

Suppose that you are modeling a queue that can physically hold 100 entities and you want to determine what proportion of the time the queue length exceeds 10. You can model the long queue as a pair of shorter queues connected in series. The shorter queues have length 90 and 10.

Although the division of the long queue into two shorter queues has no basis in physical reality, it enables you to gather statistics related to one of the shorter queues. In particular, you can view the queue length (**n**) of the queue having length 90. If the signal is positive over a nonzero time interval, then the length-90 queue contains an entity that cannot advance to the length-10 queue. This means that the length-10 queue is full. As a result, the physical length-100 queue contains more than 10 items. Determining the proportion of time the physical queue length exceeds 10 is equivalent to determining the proportion of time the queue length signal of the logical length-90 queue exceeds 0.

Vary the Service Time of a Server

You can vary the service time of a server using one of the following methods:

- Constant source, where you vary the constant
- Randomized source
- Arbitrary source
- Time-based source

Use the **Service time source** parameter of the Entity Server block to apply these methods. You can select from:

- Dialog

Enter the constant value in the **Service time value** parameter.

- Signal port

Connect a time source to the resulting signal port.

- Attribute

Enter the name of the attribute that contains data to be interpreted as service.

- MATLAB action

In the **Service time action** section, enter MATLAB code to vary the service time. Assign the variable dt , which the model uses as service time.

Random Service Times

This example is a simple queuing system in which entities arrive at a fixed deterministic rate. They then wait in a queue and advance to a server that services the entities at random intervals. It illustrates use of the Service time from random distribution design pattern.

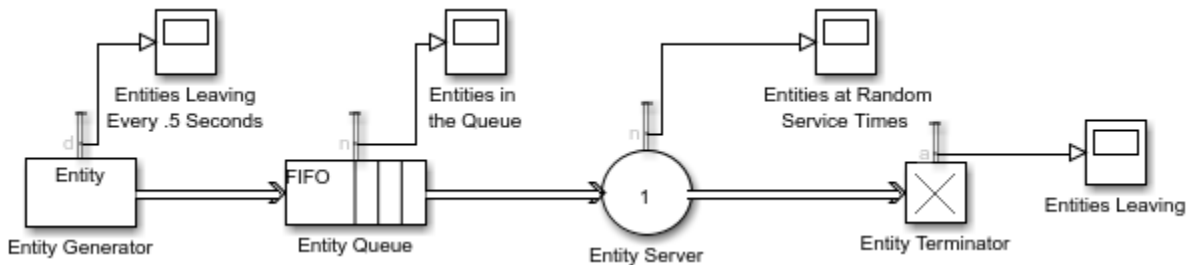

- 1 In a new model, drag the blocks shown in the example and relabel and connect them as shown. For convenience, start with the Service time from random distribution design pattern
- 2 To generate entities every .5 seconds, in the Entity Generator block:
 - a In the **Entity Generation** tab, change the **Period** to .5.
 - b In the **Statistics** tab, select **Number of entities departed, d**.
- 3 In the Entity Queue block, select **Number of entities in block, n**.
- 4 In the Entity Server block:

- a Verify that the server is configured for random service time. If not, copy the Server block from the Service time from random distribution design pattern.
 - b In the **Statistics** tab, select **Number of entities in block, n**.
- 5 In the Entity Terminator block, in the Statistics tab, select **Number of entities arrived, a**.
- 6 Save and run the model. In particular, observe the pattern of the entities leaving the Entity Generator block and the entities at random service times.

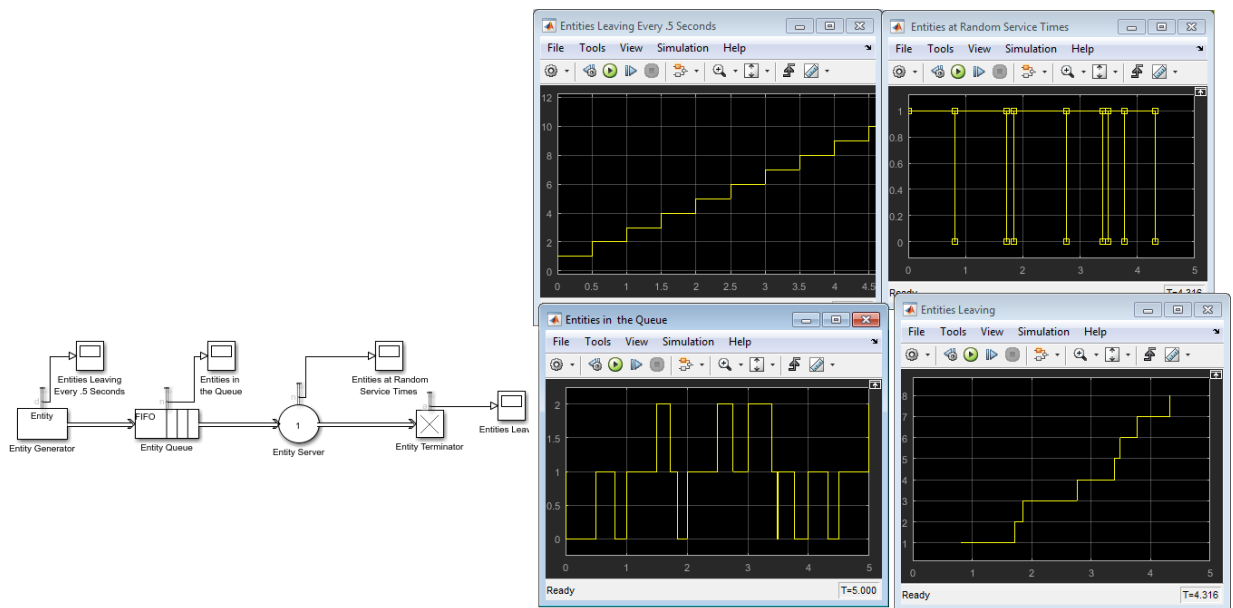

See Also

Entity Queue | Entity Server

Related Examples

- “Sort by Priority” on page 2-6
- “Task Preemption in a Multitasking Processor” on page 2-9
- “Determine Whether a Queue Is Nonempty” on page 2-12

- “Model Server Failure” on page 2-13

More About

- “Storage with Queues and Servers”

Sort by Priority

In this section...
“Behavior of Priority Mode of Entity Queue Block” on page 2-6
“Serving Preferred Customers First” on page 2-6

This example shows how to investigate the time required to serve customers in a priority queue.

Behavior of Priority Mode of Entity Queue Block

The **Priority** mode of the Entity Queue block supports queuing in which entities positions in the queue are based primarily on specific attribute values. Arrival times are relevant only when attribute values are equal. You specify the attribute and the sorting direction using the **Priority source** and **Sorting direction** parameters in the block dialog box.

Serving Preferred Customers First

In this example, two types of customers enter a queuing system. One type, considered to be preferred customers, are less common but require longer service. The priority queue places preferred customers ahead of nonpreferred customers. The model plots the average system time for the set of preferred customers and separately for the set of nonpreferred customers in a Dashboard Scope block.

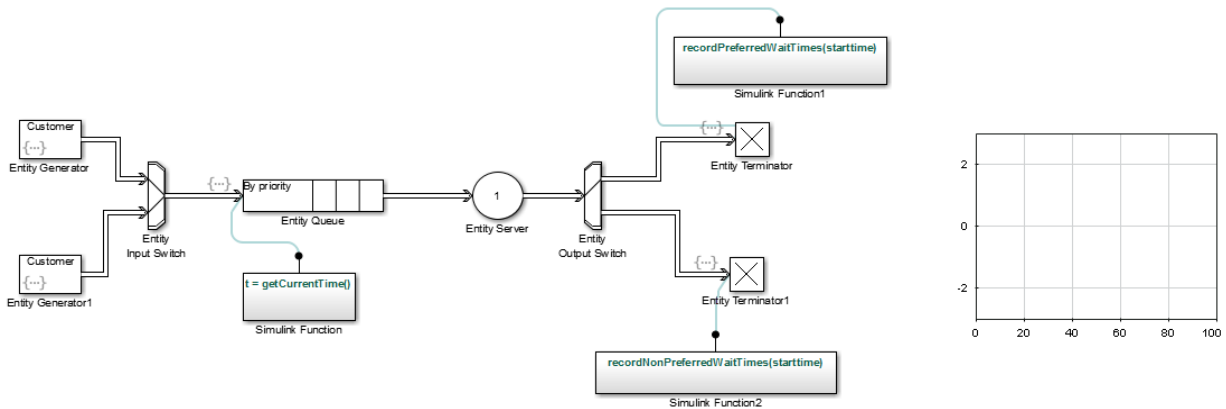

To open the example, see [Sort by Priority Example](#).

You can see from the plots that despite the shorter service time, the average system time for the nonpreferred customers is much longer than the average system time for the preferred customers.

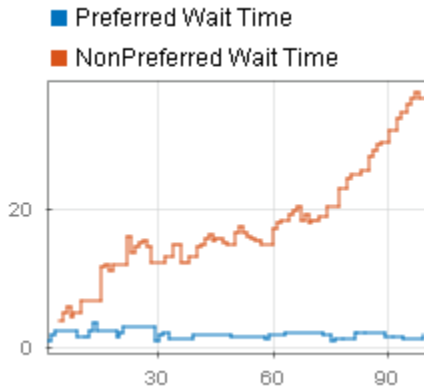

Comparison with Unsorted Behavior

If the queue used a FIFO discipline for all customers instead of a priority sorting, then the average system time would decrease slightly for the nonpreferred customers and increase markedly for the preferred customers.

See Also

[Entity Queue](#) | [Entity Server](#)

Related Examples

- [“Model Basic Queuing Systems”](#) on page 2-2
- [“Task Preemption in a Multitasking Processor”](#) on page 2-9
- [“Determine Whether a Queue Is Nonempty”](#) on page 2-12
- [“Model Server Failure”](#) on page 2-13

More About

- “Storage with Queues and Servers”

Task Preemption in a Multitasking Processor

This example shows how to force service completion in an Entity Server block using functionality available on the block **Preemption** tab.

Example Model for Task Preemption

The example shows preemption(replacement) of low priority tasks by a high priority task in a multitasking processor. In the model, the Entity Server block represents the task processor presented with a capacity to process multiple concurrent tasks.

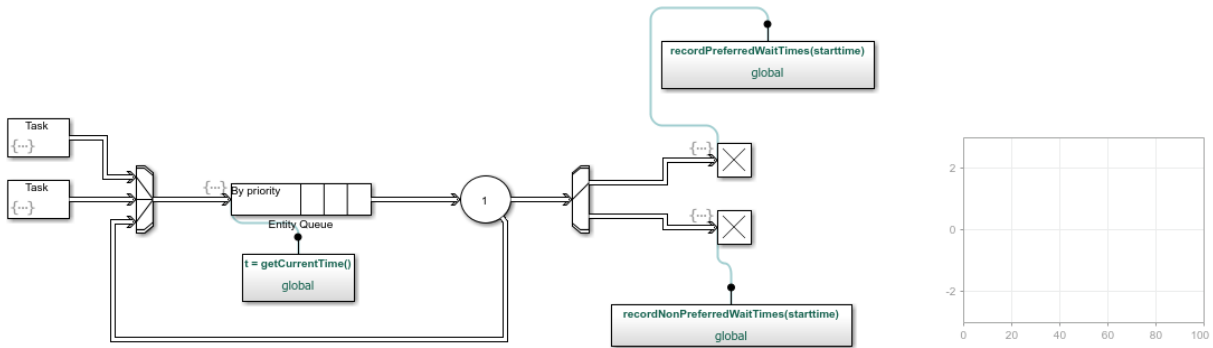

Model Behavior and Results

The following graphic shows how the model generates both low and high priority tasks.

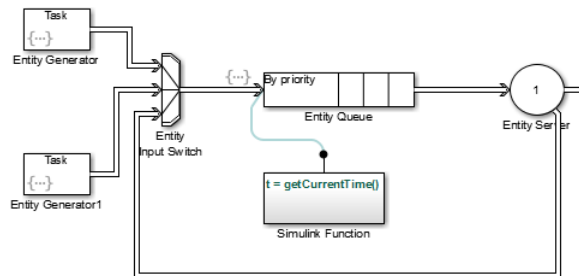

- The top and bottom Entity Generator randomly generate entities that represent high and low priority tasks, respectively. Both blocks use the exprnd function to generate

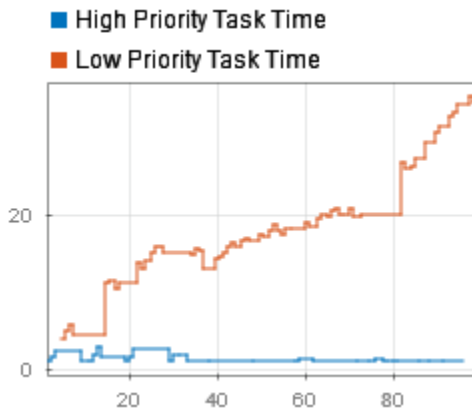

The plot displays wait time for high and low priority tasks. It can be observed that wait time of high priority tasks is significantly decreased.

See Also

Entity Queue | Entity Server

Related Examples

- “Model Basic Queuing Systems” on page 2-2
- “Sort by Priority” on page 2-6
- “Determine Whether a Queue Is Nonempty” on page 2-12
- “Model Server Failure” on page 2-13

More About

- “Storage with Queues and Servers”

Determine Whether a Queue Is Nonempty

To determine whether a queue is storing any entities, use this technique:

- 1 Enable the **n** output signal from the queue block. In the block dialog box, on the **Statistics** tab, select the **Number of entities in block, n** check box.
- 2 From the Sinks library in the Simulink library set, insert a Scope block into the model. Connect the **n** output port of the queue block to the input port of the Scope block.

The scope shows if the queue is empty.

See Also

Entity Queue | Entity Server

Related Examples

- “Model Basic Queuing Systems” on page 2-2
- “Sort by Priority” on page 2-6
- “Task Preemption in a Multitasking Processor” on page 2-9
- “Model Server Failure” on page 2-13

More About

- “Storage with Queues and Servers”

Model Server Failure

In this section...

“Server States” on page 2-13

“Use a Gate to Implement a Failure State” on page 2-13

Server States

In some applications, it is useful to model situations in which a server fails. For example, a machine breaks down and later is repaired, or a network connection fails and later is restored. This section explores ways to model failure of a server, and server states.

Server blocks do not have built-in states, so you can design states in any way that is appropriate for your application. Some examples of possible server states are in this table.

Server as Communication Channel	Server as Machine	Server as Human Processor
Transmitting message	Processing part	Working
Connected but idle	Waiting for new part to arrive	Waiting for work
Unconnected	Off	Off duty
Holding message (pending availability of destination)	Holding part (pending availability of next operator)	Waiting for resource
Establishing connection	Warming up	Preparing to begin work

Use a Gate to Implement a Failure State

For any state that represents a server inability or refusal to accept entity arrivals even though the server is not necessarily full, a common implementation involves an Entity Gate block preceding the server.

The gate prevents entity access to the server whenever the gate control message at the input port at the top of the block carries zero or negative values. The logic that creates the control message determines whether the server is in a failure state. You can implement such logic using the Simulink Function block, using a Message Send block, or using Stateflow® charts to transition among a finite number of server states.

This example shows an instance in which an Entity Gate block precedes a server. The example is not specifically about a failure state, but the idea of controlling access to a server is similar. It models a stochastically occurring failure that lasts for some amount of time.

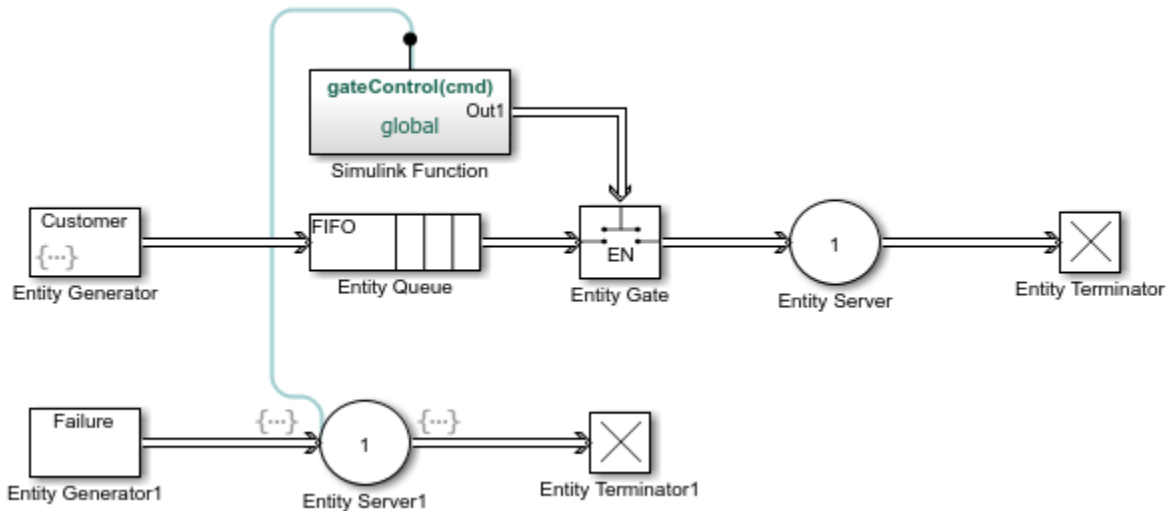

Note: The gate prevents new entities from arriving at the server but does not prevent the current entity from completing its service. If you want to eject the current entity from the server upon a failure occurrence, then you can use the preemption feature of the server to replace the current entity with a high-priority 'placeholder' entity.

See Also

Entity Queue | Entity Server

Related Examples

- “Model Basic Queuing Systems” on page 2-2
- “Sort by Priority” on page 2-6
- “Task Preemption in a Multitasking Processor” on page 2-9
- “Determine Whether a Queue Is Nonempty” on page 2-12

More About

- “Storage with Queues and Servers”

Routing Techniques

- “Role of Paths in SimEvents Models” on page 3-2
- “Route Vehicles Using an Entity Output Switch Block” on page 3-4
- “Control Output Switch with Event Actions and Simulink Function” on page 3-8
- “Match Entities Based on Attributes” on page 3-11
- “Use Attributes to Route Entities” on page 3-13
- “Role of Gates in SimEvents Models” on page 3-14
- “Enable a Gate for a Time Interval” on page 3-16

Role of Paths in SimEvents Models

In this section...
“Definition of Entity Paths” on page 3-2
“Implications of Entity Paths” on page 3-2
“Overview Blocks for Designing Paths” on page 3-2

Definition of Entity Paths

An entity path is a connection from an entity output port to an entity input port, depicted as a line connecting the entity ports of two SimEvents blocks. An entity path represents the equivalence between an entity's departure from the first block and arrival at the second block. For example, any entity that departs from the output port of an Entity Queue block set to FIFO mode equivalently arrives at an Entity Server block input port.

The existence of the entity path does not guarantee that any entity actually uses the path; for example, the simulation could be so short that no entities are ever generated. Even when an entity path is used, it is used only at a discrete set of times during the simulation.

Implications of Entity Paths

In some models, you can use the entity connection lines to infer the full sequence of blocks that a given entity arrives at, throughout the simulation.

In many discrete-event models, however, the set of entity connection lines does not completely determine the sequence of blocks that each entity arrives at.

By looking at entity connection lines alone, you cannot tell which queue block's input port an entity will arrive at. Instead, you need to know more about how the Entity Output Switch block behaves and you might even need to know the outcome of certain run-time decisions.

Overview Blocks for Designing Paths

You design entity paths by choosing or combining entity paths using these blocks:

- Entity Input Switch
- Entity Output Switch
- Entity Replicator

These blocks have extra entity ports that let you vary the model's topology (that is, the set of blocks and connection lines).

Typical reasons for manipulating entity paths are

- To describe an inherently parallel behavior in the situation you are modeling — for example, a computer cluster with two computers that share the computing load. You can use the Entity Output Switch block to send computing jobs to one of the two computers. You might also use the Entity Input Switch block if computing jobs share a common destination following the pair of computers.
- To design nonlinear topologies, such as feedback loops — for example, repeating an operation if quality criteria such as quality of service (QoS) are not met. You can use the Entity Input Switch block to combine the paths of new entities and entities that require a repeated operation.
- To incorporate logical decision making into your simulation — for example, determining scheduling protocols. You might use the Entity Input Switch block to determine which of several queues receives attention from a server.

Other blocks in the SimEvents library have secondary features, such as preemption from a server, that give you opportunities to design paths.

See Also

Entity Gate | Entity Input Switch | Entity Output Switch | Entity Replicator

Related Examples

- “Control Output Switch with Event Actions and Simulink Function” on page 3-8
- “Enable a Gate for a Time Interval” on page 3-16

More About

- “Use Attributes to Route Entities” on page 3-13
- “Role of Gates in SimEvents Models” on page 3-14

Route Vehicles Using an Entity Output Switch Block

This example shows how to route vehicles to two different pumps in a gas station by controlling an Entity Output Switch block.

In the example, vehicles are generated by an Entity Generator block, which represents vehicle arrival. After their arrival, vehicles are routed to two different gas pumps using an Entity Output Switch block. A Simulink Function block controls the selected output port of the Entity Output Switch block. The vehicle's departure from the Entity Generator block invokes the Simulink Function block.

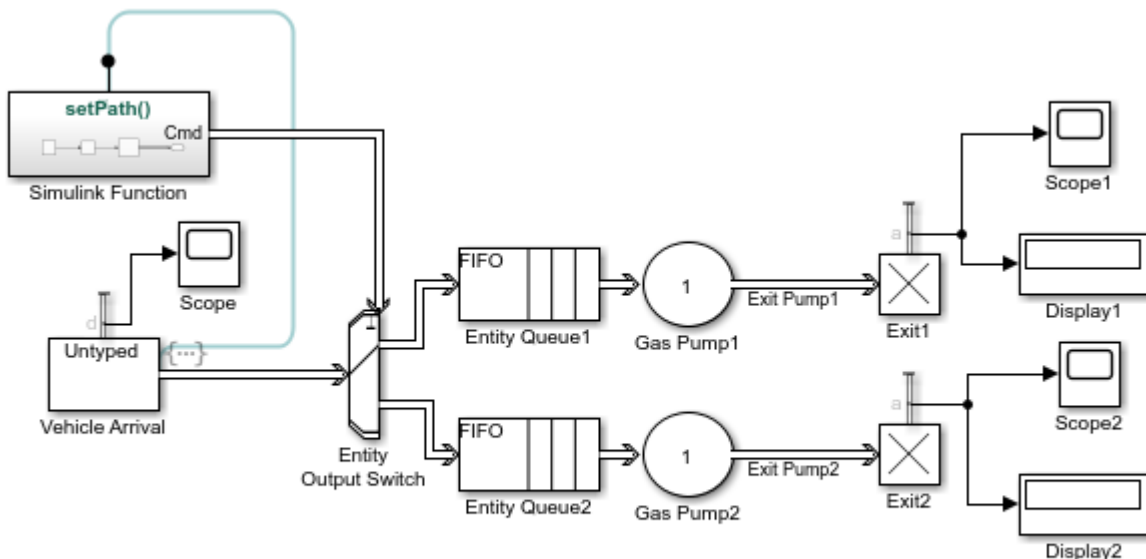

Copyright 2019 The MathWorks, Inc.

Control Entity Output Switch Block

- In the Entity Output Switch Block, set the **Switching Criterion** to From control port.
- In the Simulink Function block, use a Uniform Random Number block to generate random numbers between 1 and 2.

- The generated random number is rounded to the integers 1 or 2 by the Round block.
- The integer value of the signal is converted to a message by the Message Send block.
- The output value from the Simulink Function block corresponds to the selected output of the Entity Output Switch block.

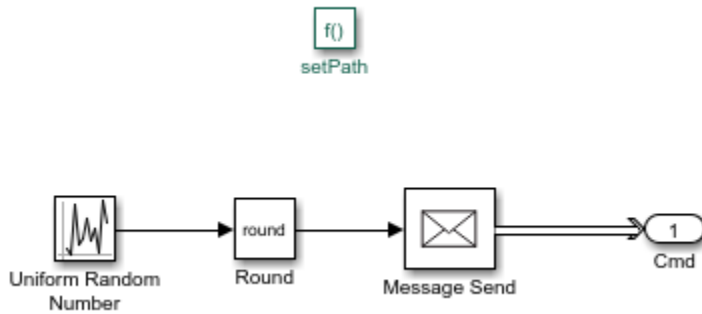

Simulate Model and Review Results

Simulate the model and observe that 14 vehicles use Gas Pump1 and 16 vehicles use Gas Pump2.

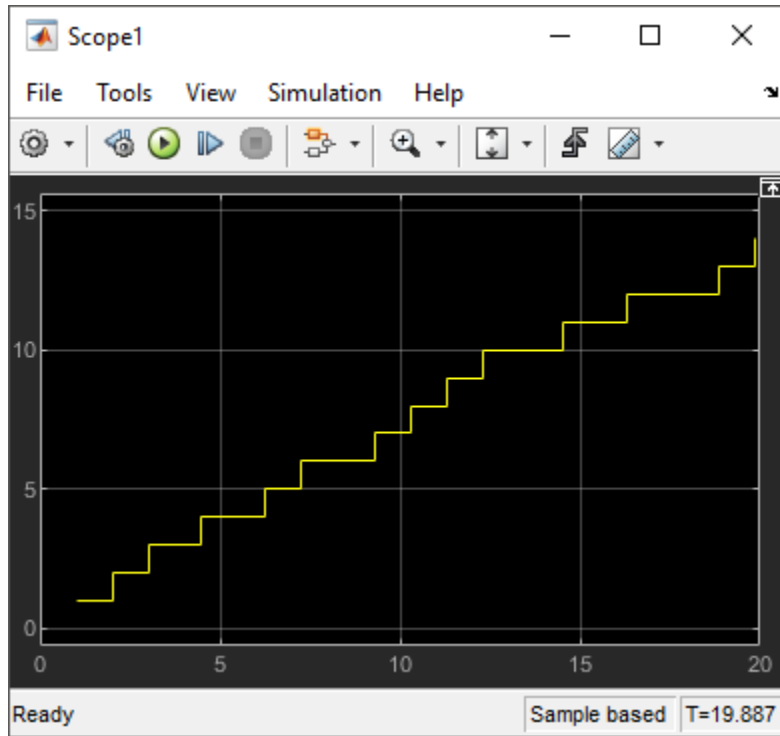

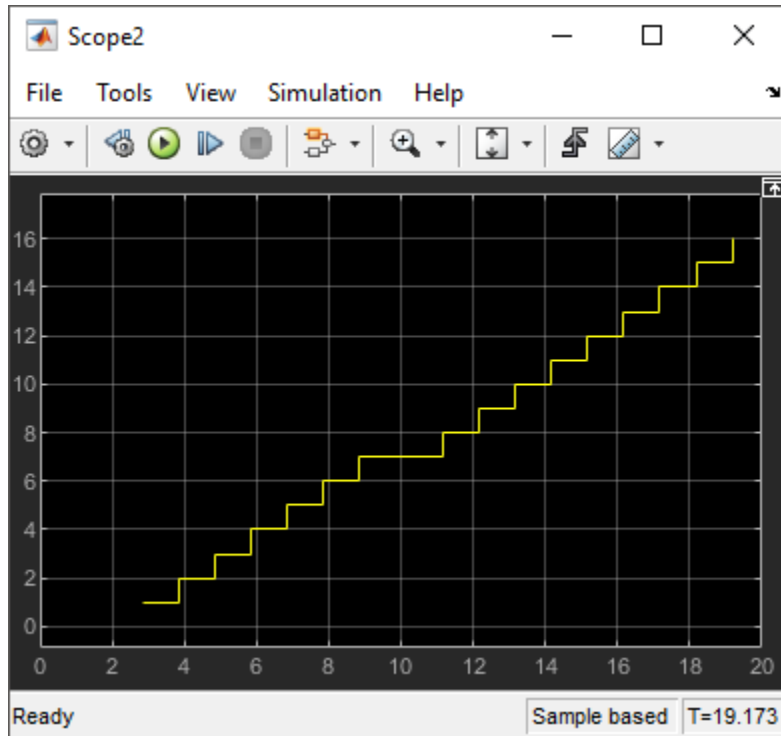

See Also

Entity Server | Entity Terminator | Entity Generator | Entity Output Switch

More About

- “Control Output Switch with Event Actions and Simulink Function” on page 3-8
- “Match Entities Based on Attributes” on page 3-11

Control Output Switch with Event Actions and Simulink Function

In this section...

“Control Output Switch with a Simulink Function Block” on page 3-8

“Specify an Initial Port Selection” on page 3-9

This example shows how to change the selected output port of an Entity Output Switch block to route entities along different paths where a path is selected on a per-entity basis, not on a predetermined time schedule.

Control Output Switch with a Simulink Function Block

The following example illustrates a scenario in which the Entity Output Switch block is controlled by the Simulink Function block.

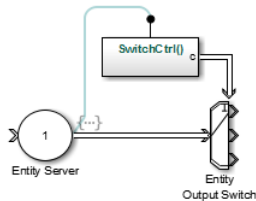

- 1 Double-click the function signature on the Simulink Function block and enter `SwitchCtrl()`.
- 2 Double-click the Simulink Function block. Add a Repeating Sequence Stair block, and set its **Sample time** parameter to -1 (inherited), a Message Send block and an Out1 block. Connect the blocks as shown.

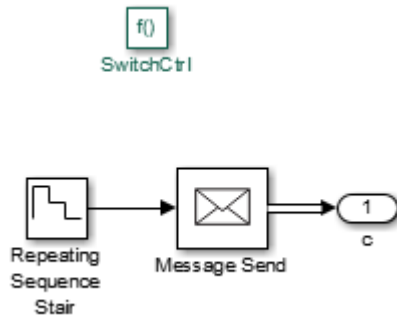

- 3 In the Repeating Sequence Stair block, set the **Vector of output values** to [3 2 1].

When the Simulink Function block executes, it outputs the next number from a repeating sequence and Message Send block outputs message values 3, 2, or 1 based on the sequence of values specified in the Repeating Sequence Stair block.

- 4 In the Entity Server block, in the **Exit action** field enter this code.

```
SwitchCtrl();
```

When service in the Entity Server block is complete, the entity exits the block and advances to the Entity Output Switch block. The departure of the entity from the Entity Server block calls the `SwitchCtrl()` function which activates the Simulink Function block. Then the output message of the Simulink Function block determines which output port the entity uses when it departs the Entity Output Switch block.

Specify an Initial Port Selection

When the Entity Output Switch block uses an input message, the block might attempt to use the message before its first sample time hit. If the initial value of the message is out of range (for example, it is unavailable). You should then specify the initial port selection in the Entity Output Switch block's dialog box. To achieve this, you can follow these steps.

- 1 In the Entity Output Switch, select From control port as the **Switching criterion**.
- 2 Set **Initial port selection** to the desired initial port. The value must be an integer between 1 and **Number of output ports**. The Entity Output Switch block uses **Initial port selection** until the first control port message arrives.

See Also

Entity Gate | Entity Input Switch | Entity Output Switch | Entity Replicator

Related Examples

- “Enable a Gate for a Time Interval” on page 3-16

More About

- “Role of Paths in SimEvents Models” on page 3-2
- “Use Attributes to Route Entities” on page 3-13
- “Role of Gates in SimEvents Models” on page 3-14

Match Entities Based on Attributes

This example shows how to build a model to store and match entities representing bicycle components. The model uses an Entity Store block for storage and an Entity Selector block to match a set of bicycle wheels to the corresponding size frame for assembly.

Produce Bicycle Frames and Wheels

Suppose that you are modeling an assembly line that produces bicycles sized small, medium, and large. Each bicycle is manufactured by matching the set of wheels to the corresponding size frame. The wheels are produced at a facility. The frames are ordered from a supplier and they arrive at the facility ready to assemble. Given this arrangement, frame arrival rate is slower than the wheel production rate, and the set of wheels are stored in a bin.

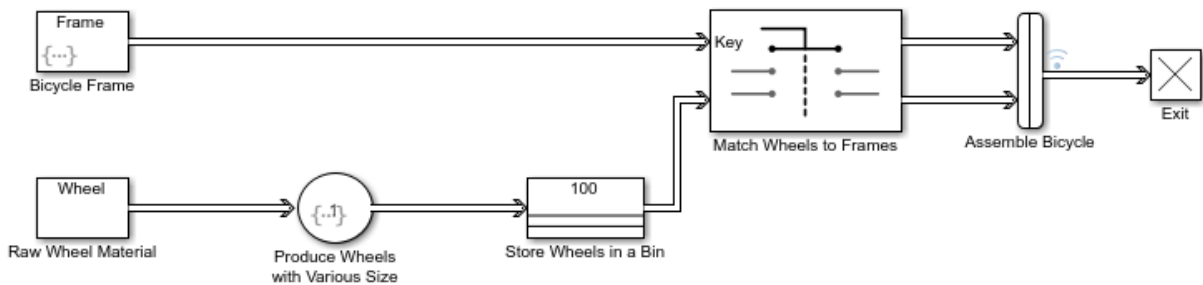

Copyright 2019 The MathWorks, Inc.

In the model:

- The Bicycle Frame Block generates `Frame` with **Period** 5 to represent slow arrival rate of bicycle frames. A `Frame` can be of size 1, 2, or 3, and each `Frame` carries an attribute `FrameSize` that represents its size.
- The Raw Wheel Material Block generates `Wheel` with **Period** 1. Each `Wheel` carries a `WheelSize` attribute that represents the size of each generated wheel. The initial value of `WheelSize` is set to 0.
- In the Produce Wheels with Various Size block, wheels are set to size 1, 2, or 3.
- The Entity Store block is named Store Wheels in a Bin and it stores the processed wheels.

- The Entity Selector block is named Match Wheels to Frames and it matches 'WheelSize' to the corresponding 'FrameSize'.

Simulate the Model and Review Results

Simulate the model. Open the Simulation Data Inspector. Observe that, for the bicycle assembly, the size of the set of wheels and the frames are exactly matched by the Entity Selector block. Although the wheels are generated faster, they are stored in the Entity Store block, and they wait to be matched to the arriving frames for assembly.

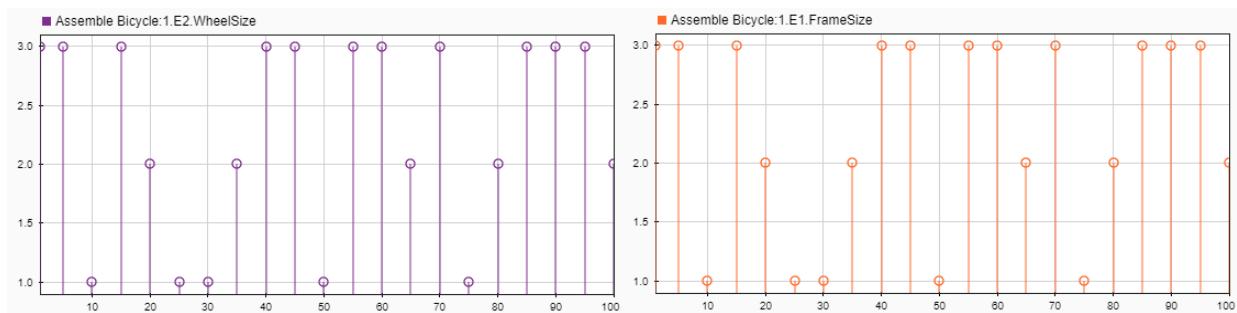

See Also

[Composite Entity Creator](#) | [Entity Selector](#) | [Entity Store](#) | [Entity Gate](#) | [Entity Server](#)

Related Examples

- “Control Output Switch with Event Actions and Simulink Function” on page 3-8
- “Enable a Gate for a Time Interval” on page 3-16

More About

- “Working with Entity Attributes” on page 1-37
- “Role of Paths in SimEvents Models” on page 3-2
- “Role of Gates in SimEvents Models” on page 3-14

Use Attributes to Route Entities

Suppose entities represent manufactured items that undergo a quality control process followed by a packaging process. Items that pass the quality control test proceed to one of three packaging stations, while items that fail the quality control test proceed to one of two rework stations. You can model the decision making using these switches:

- An Entity Output Switch block that routes items based on an attribute that stores the results of the quality control test
- An Entity Output Switch block that routes passing-quality items to the packaging stations
- An Entity Output Switch block that routes failing-quality items to the rework stations

You can use the block **Switching criterion** parameter `From attribute` option to use an attribute to select the output port. For an example, see “Model Traffic Intersections as a Queuing Network” on page 5-17.

See Also

Entity Gate | Entity Input Switch | Entity Output Switch | Entity Replicator

Related Examples

- “Control Output Switch with Event Actions and Simulink Function” on page 3-8
- “Enable a Gate for a Time Interval” on page 3-16

More About

- “Role of Paths in SimEvents Models” on page 3-2
- “Role of Gates in SimEvents Models” on page 3-14

Role of Gates in SimEvents Models

In this section...
“Overview of Gate Behavior” on page 3-14
“Gate Behavior” on page 3-15

Overview of Gate Behavior

By design, certain blocks change their availability to arriving entities depending on the circumstances. For example,

- A queue or server accepts arriving entities as long as it is not already full to capacity.
- An input switch accepts an arriving entity through a single selected entity input port but forbids arrivals through other entity input ports.

Some applications require more control over whether and when entities advance from one block to the next. A gate provides flexible control via its changing status as either open or closed: by definition, an open gate permits entity arrivals as long as the entities would be able to advance immediately to the next block, while a closed gate forbids entity arrivals. You configure the gate so that it opens and closes under circumstances that are meaningful in your model.

For example, you might use a gate

- To create periods of unavailability of a server. For example, you might be simulating a manufacturing scenario over a month long period, where a server represents a machine that runs only 10 hours per day. An enabled gate can precede the server, to make the server's availability contingent upon the time.
- To make departures from one queue contingent upon departures from a second queue. A release gate can follow the first queue. The gate's control input determines when the gate opens, based on decreases in the number of entities in the second queue.
- With the **First port that is not blocked** mode of the Entity Output Switch block. Suppose each entity output port of the switch block is followed by a gate block. An entity attempts to advance via the first gate; if it is closed, then the entity attempts to advance via the second gate, and so on.

Gate Behavior

The Entity Gate block offers these fundamentally different kinds of gate behavior:

- The enabled gate, which uses a control port to determine time intervals over which the gate is open or closed
- The release gate, which uses a control port to determine a discrete set of times at which the gate is instantaneously open. The gate is closed at all other times during the simulation.

Tip Many models follow a gate with a storage block, such as a queue or server.

See Also

Entity Gate | Entity Input Switch | Entity Output Switch | Entity Replicator

Related Examples

- “Control Output Switch with Event Actions and Simulink Function” on page 3-8
- “Enable a Gate for a Time Interval” on page 3-16

More About

- “Role of Paths in SimEvents Models” on page 3-2
- “Use Attributes to Route Entities” on page 3-13

Enable a Gate for a Time Interval

In this section...
“Behavior of Entity Gate Block in Enabled Mode” on page 3-16
“Sense an Entity Passing from A to B and Open a Gate” on page 3-16
“Control Joint Availability of Two Servers” on page 3-18

Behavior of Entity Gate Block in Enabled Mode

The Entity Gate block uses a control signal at the input port at the top of the block to determine when the gate is open or closed:

- When an entity with a positive payload arrives at the enable port at the top of the block, the gate is open and an entity can arrive as long as it would be able to advance immediately to the next block.
- When an entity with zero or negative payload arrives at the enable port at the top of the block, the gate is closed and no entity can arrive.

Because that incoming signal can remain positive for a time interval of arbitrary length, an enabled gate can remain open for a time interval of arbitrary length. The length can be zero or a positive number.

Depending on your application, the gating logic can arise from time-driven dynamics, state-driven dynamics, a SimEvents block's statistical output signal, or a computation involving various types of signals. To see the ready-to-use common design patterns including the Entity gate block, see “SimEvents Common Design Patterns”.

Sense an Entity Passing from A to B and Open a Gate

This example shows how to use the Sense an Entity Passing from A to B and Open a Gate design pattern. In this example, the Step block generates a step signal at time 4. This signal passes through the Message Send block A. The Entity Replicator block duplicates the entity and passes it to B. It uses the original entity to trigger an event-based entity to enable the Entity Gate block.

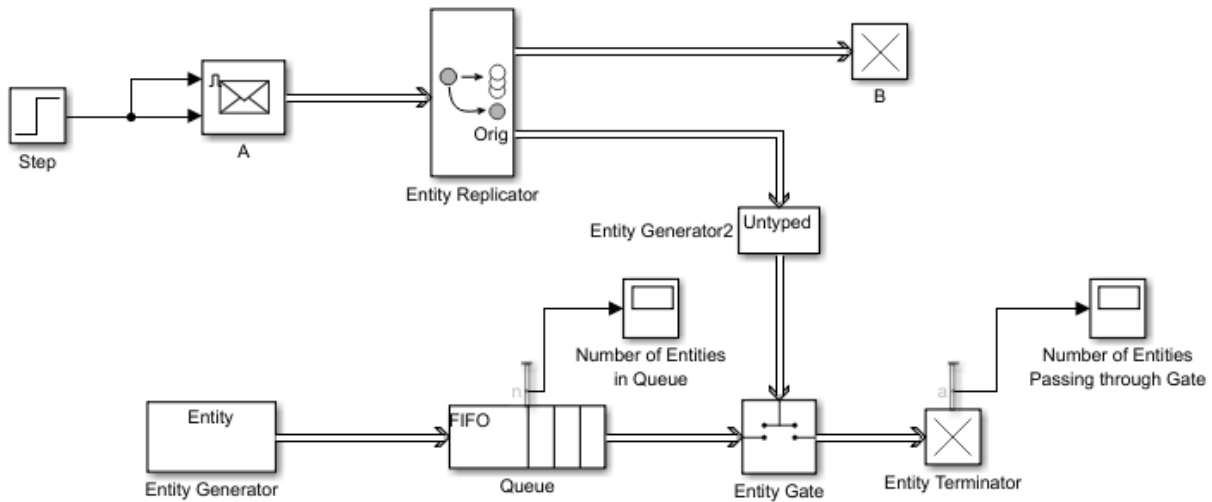

- 1 In a new model, drag the blocks shown in the example and relabel and connect them as shown. For convenience, start with the Sense an Entity Passing from A to B and Open a Gate design pattern.
- 2 In the Step block, set the **Step time** parameter to 4.
- 3 In the A (Message Send) block, select the **Show enable port** check box. Selecting this check box lets the Step block signal enable the A block to send a message to the Entity Replicator block.
- 4 In the Entity Generator block, in the Entity type tab:
 - a Name the entity type Entity.
 - b Add an attribute named Capacity with an initial value of 0.
- 5 In the Entity Queue block, in the **Statistics** tab, select **Number of entities in block, n**.
- 6 Save and run the model. Observe the number of entities passing through the gate and the number of entities in the queue at time 4.

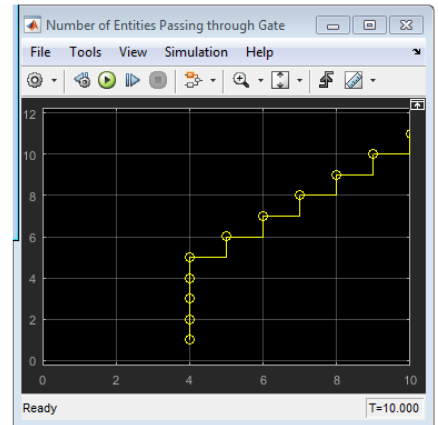
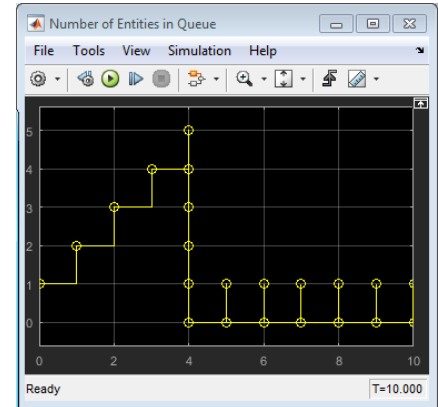
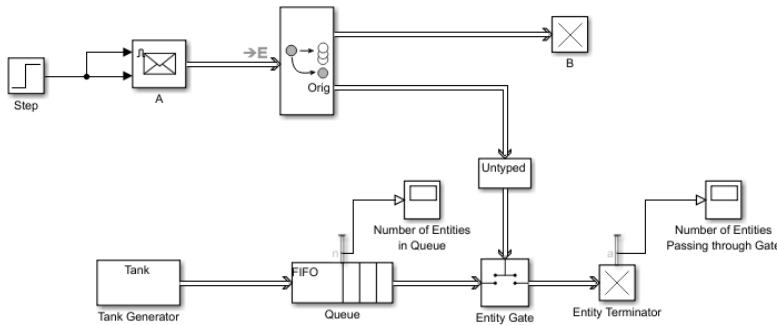

Control Joint Availability of Two Servers

Suppose that each entity undergoes two processes, one at a time, and that the first process does not start if the second process is still in progress for the previous entity. Assume for this example that it is preferable to model the two processes using two Single Server blocks in series rather than one Single Server block whose service time is the sum of the two individual processing times; for example, you might find a two-block solution more intuitive or you might want to access the two Single Server blocks' utilization output signals independently in another part of the model.

If you connect a queue, a server, and another server in series, then the first server can start serving a new entity while the second server is still serving the previous entity. This

does not accomplish the stated goal. The model needs a gate to prevent the first server from accepting an entity too soon, that is, while the second server still holds the previous entity.

See Also

Entity Gate | Entity Input Switch | Entity Output Switch | Entity Replicator | Message Send

Related Examples

- “Control Output Switch with Event Actions and Simulink Function” on page 3-8

More About

- “Role of Paths in SimEvents Models” on page 3-2
- “Use Attributes to Route Entities” on page 3-13
- “Role of Gates in SimEvents Models” on page 3-14

Work with Resources

- “Model Using Resources” on page 4-2
- “Set Resource Amount with Attributes” on page 4-4
- “Process Batched Entities Using Event Actions” on page 4-6
- “Find and Extract Entities in SimEvents Models” on page 4-10

Model Using Resources

In this section...

“Resource Blocks” on page 4-2

“Resource Creation Workflow” on page 4-2

Resource Blocks

Resources are commodities shared by entities in your model. They are independent of entities and attributes, and can exist in the model even if no entity exists or uses them. Resources are different from attributes, which are associated with entities and exist or disappear with their entity.

For example, if you are modeling a restaurant, you can create tables and food as resources for customer entities. Entities can access resources from types of resources.

The SimEvents software supplies the following resource allocation blocks:

Action	Block
Acquire resource	Resource Acquirer
Define resource	Resource Pool
Release resource	Resource Releaser

Resource Creation Workflow

- 1 Specify resources using the Resource Pool block. Define one resource per Resource Pool block. Multiple Resource Pool blocks can exist in the model with multiple entities sharing the resources.
- 2 Identify resources to be used with the Resource Acquirer block. You can identify these resources before specifying them in a Resource Pool block, or select them from the available resources list. However, the resource definitions must exist by the time you simulate the model. Multiple Resource Acquire blocks can exist in the model.
- 3 To release resources, include one or more Resource Releaser blocks. You can configure Resource Release blocks to release some or all resources for an entity. Alternatively, you can release all resources for an entity directly using the Entity Terminator block.

Tip To determine how long an entity holds a resource, insert a server block after the Resource Acquire block. In the **Service time** parameter, enter how long you want the entity to hold the resource.

An entity implicitly releases held resources when it:

- Is destroyed.
- Enters an Entity Replicator block and the block creates multiple copies of that entity.
- Is combined with other entities using the Composite Entity Creator block.
- Is split into its component entities using the Composite Entity Splitter block.

See Also

Resource Acquirer | Resource Pool | Resource Releaser

Set Resource Amount with Attributes

Use the **Selected Resources** table of the Resource Acquirer block to receive the resource amount definition from the block dialog box or an entity attribute. Using attributes as the source for the resource requires synchronicity between these blocks:

- Entity Generator block with the attribute definition that Resource Acquirer wants to supply the source amount
- Resource Pool block that defines the resource
- Resource Acquirer block that acquires the resource

This example shows this synchronicity.

- 1** Open a new model and add Resource Pool, Entity Generator, and Resource Acquirer blocks. For the Resource Pool block:
 - Set **Resource name** to water.
 - Set **Resource amount** to 20.
 - In the **Statistics** tab, select **Amount in use, #u**.
- 2** In the Entity Generator block dialog box, click the **Entity type** tab and in the **Define attributes** table:
 - Enter the attribute name, `water_amount`, to indicate that the attribute defines the amount of the resource.
 - Set the value to 10.
- 3** In the Resource Acquirer block dialog box, click the **Entity type** tab and under Available Resources, select `water` and move it to the **Selected Resources** table.
- 4** In the **Selected Resources** table, in the `water` entry:
 - For **Amount Source**, select `Attribute`.
 - For **Amount**, enter `water_amount` to match the attribute name defined in the Entity Generator block.
- 5** To complete the model, add the following blocks and connect them as shown in the figure:
 - Entity Terminator (select the **Statistics** tab **Number of entities arrived, #a** check box)

- Two Scope blocks

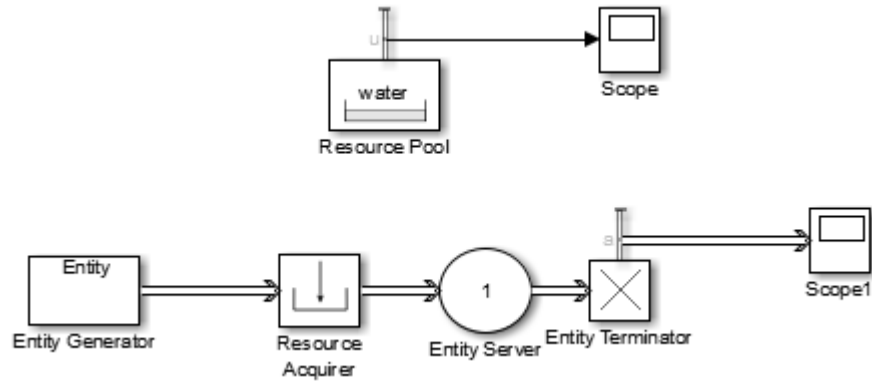

- 6 Simulate the model and observe the amount of resources in use (Scope).

See Also

Resource Acquirer | Resource Pool | Resource Releaser

Process Batched Entities Using Event Actions

This example shows how to create, process, and split batched entities using Entity Batch Creator and Entity Batch Splitter blocks. In the model, An Entity Generator block is used to represent produced parts in a facility. The parts are batched by an Entity Batch Creator block. A batch is processed by an Entity Server block. When the processing is complete, the batch is split into individual parts by the Entity Batch Splitter block for their delivery.

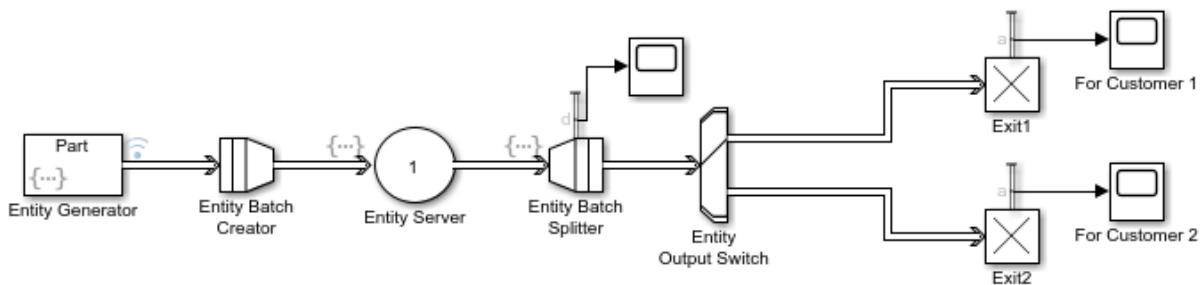

Copyright 2019 The MathWorks, Inc.

In the model:

- Use an Entity Generator block to generate a Part with two attributes, Color and Customer, representing color and delivery destination. To generate three different colors and two different delivery destinations for each Part, in the **Event actions** tab, in the **Generate action** field enter this code. field:

```
entity.Color = randi([1 3]);
entity.Customer = randi([1 2]);
```

- Use an Entity Batch Creator block to generate a batch that contains four parts.
- Use an Entity Server block to process and change the color of the third Part in each batch. In the **Event actions** tab, in the **Entry** field enter this code.

```
entity.batch(3).Color = 5;
```

- Use an Entity Batch Splitter block to split parts. In the **Entry action**, use `disp(entity.batch(3).Color)` to display the color of the third Part in each processed batch.

- Use an Entity Output Switch block to route a Part to the corresponding customer based on its Customer attribute.

Simulate Model and Review Results

Simulate the model.

Open the Simulation Data Inspector and observe that the parts are generated with Color values 1, 2, or 3.

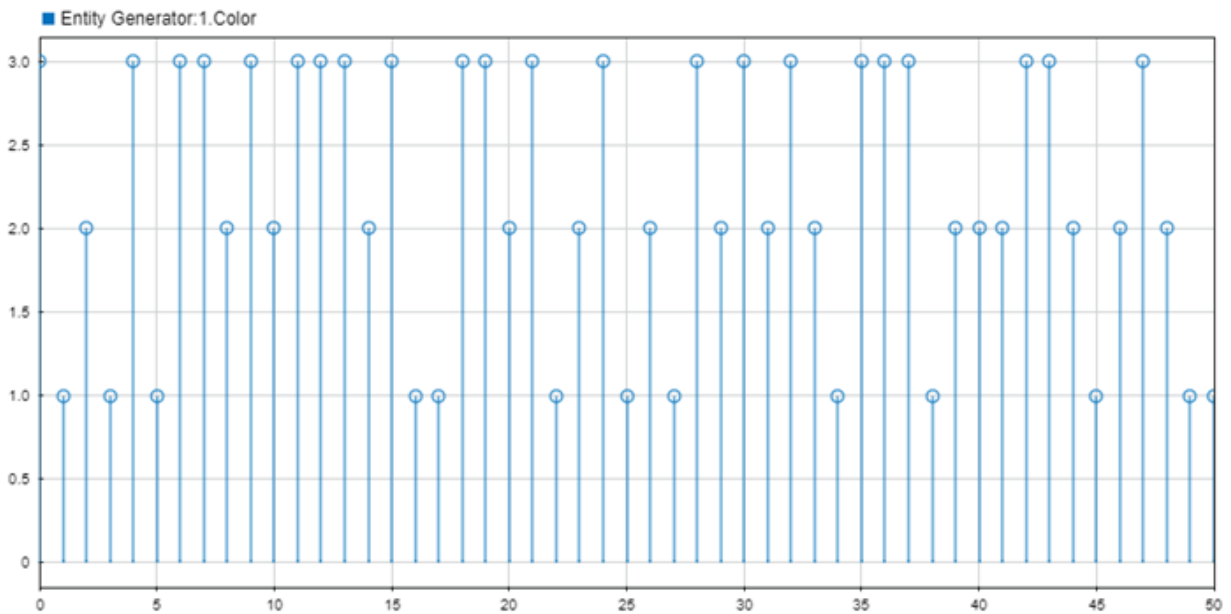

- Observe that the Diagnostic Viewer displays Color values of the third entity in each batch after batch processing.

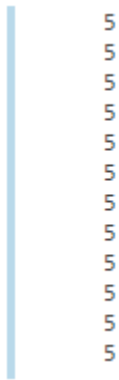

- Scope blocks labeled as For Customer 1 and For Customer 2 display the number of parts delivered to each customer.

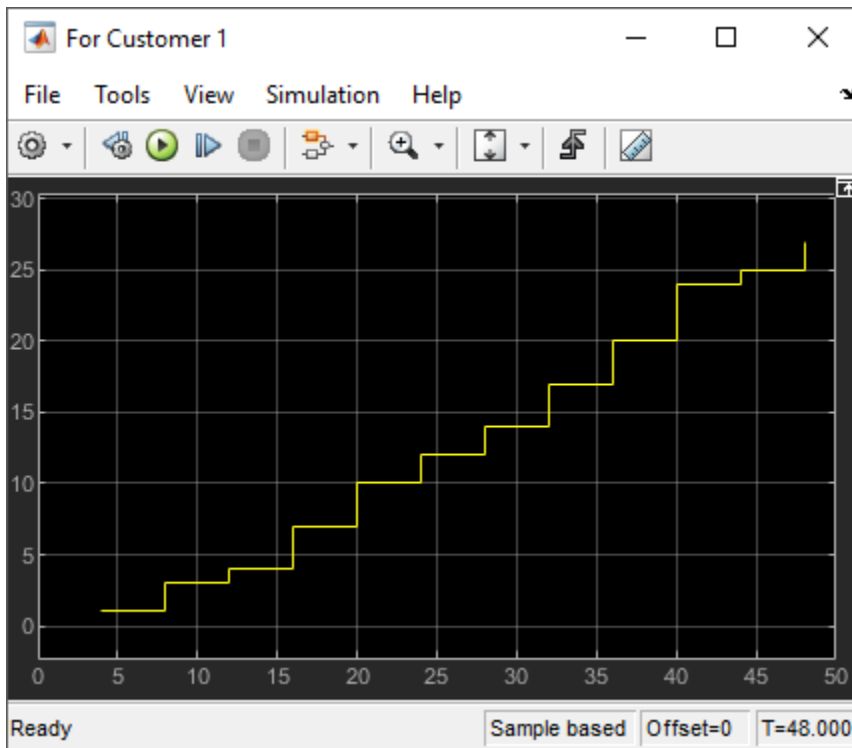

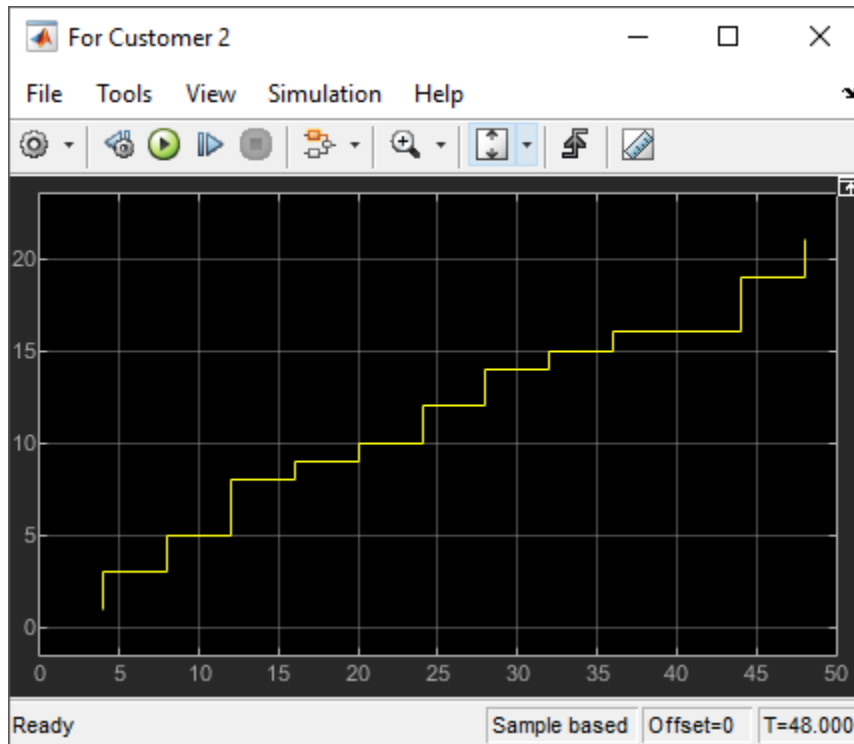

See Also

Entity Batch Creator | Entity Batch Splitter | Entity Generator | Entity Output Switch | Entity Server

More About

- “Model Using Resources” on page 4-2
- “Optimize SimEvents Models by Running Multiple Simulations” on page 5-26
- “Find and Extract Entities in SimEvents Models” on page 4-10
- “Resource Scheduling Using MATLAB Discrete-Event System and Data Store Memory Blocks” on page 9-80

Find and Extract Entities in SimEvents Models

You can find entities in a SimEvents model by using an Entity Find block. The block searches and finds entities that use a particular resource from a Resource Pool block and acquire it through a Resource Acquirer block.

You can use the Entity Find block for these applications.

- Model a supply chain to monitor perishable items and update the inventory records. For instance, you can modify the price of an item when it is closer to its expiration date.
- Model timers and perform actions on products based on timers.
- Model recall of products from a supply chain. You can reroute recalled products back to the supply chain after repair.

Finding and Examining Entities

The Entity Find block helps you find and examine entities at their location. In this example, the block finds entities that are tagged with a Resource1 resource from the Resource Pool block. Then, an additional filtering condition helps to further filter the found entities.

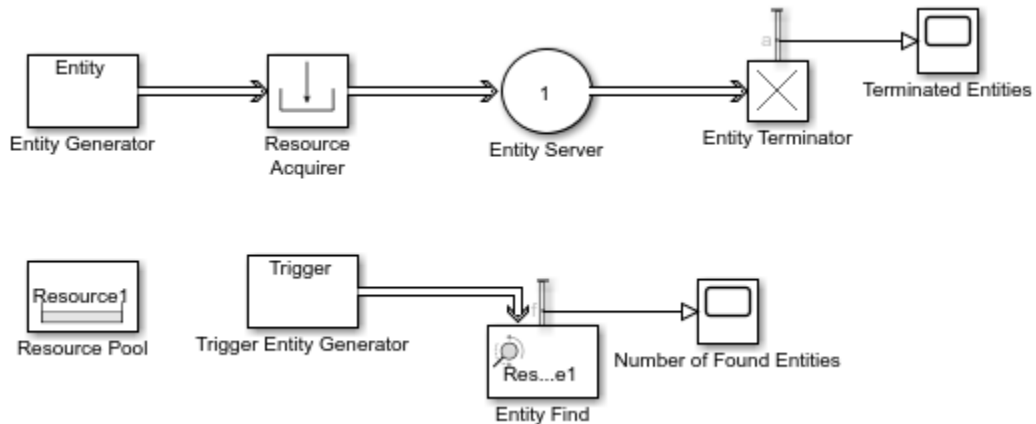

- 1 Add an Entity Generator block, Resource Pool block, Resource Acquirer block, Entity Server block, and Entity Terminator block.

The top model represents the flow of entities that acquires a Resource1 resource.

- 2 In the Entity Terminator block, output the **Number of entities arrived, a** statistic and connect to a scope.
- 3 Add an Entity Find block. Output the **Number of entities found, f** statistic and connect it to a scope.

By default, the block finds entities with the Resource1 tag.

- 4 Add another Entity Generator block and label it Trigger Entity Generator. Connect it to the input port of the Entity Find block. In the block, change the **Entity type name** to Trigger and **Entity priority** to 100.

Every time the Trigger Entity Generator generates a trigger entity, the Entity Find block is triggered to find entities.

Note The entities in the model have priority 300 and the priority of the trigger entity is set to 100 to make trigger entities higher priority in the event calendar. This prevents the termination of the entities before they are found by the Entity Find block.

- 5 Simulate the model and observe that the number of terminated entities is 10, which is equal to the number of found entities by the Entity Find block. Every generated entity acquires a Resource1 tag and there is no blocking of entities in the model.

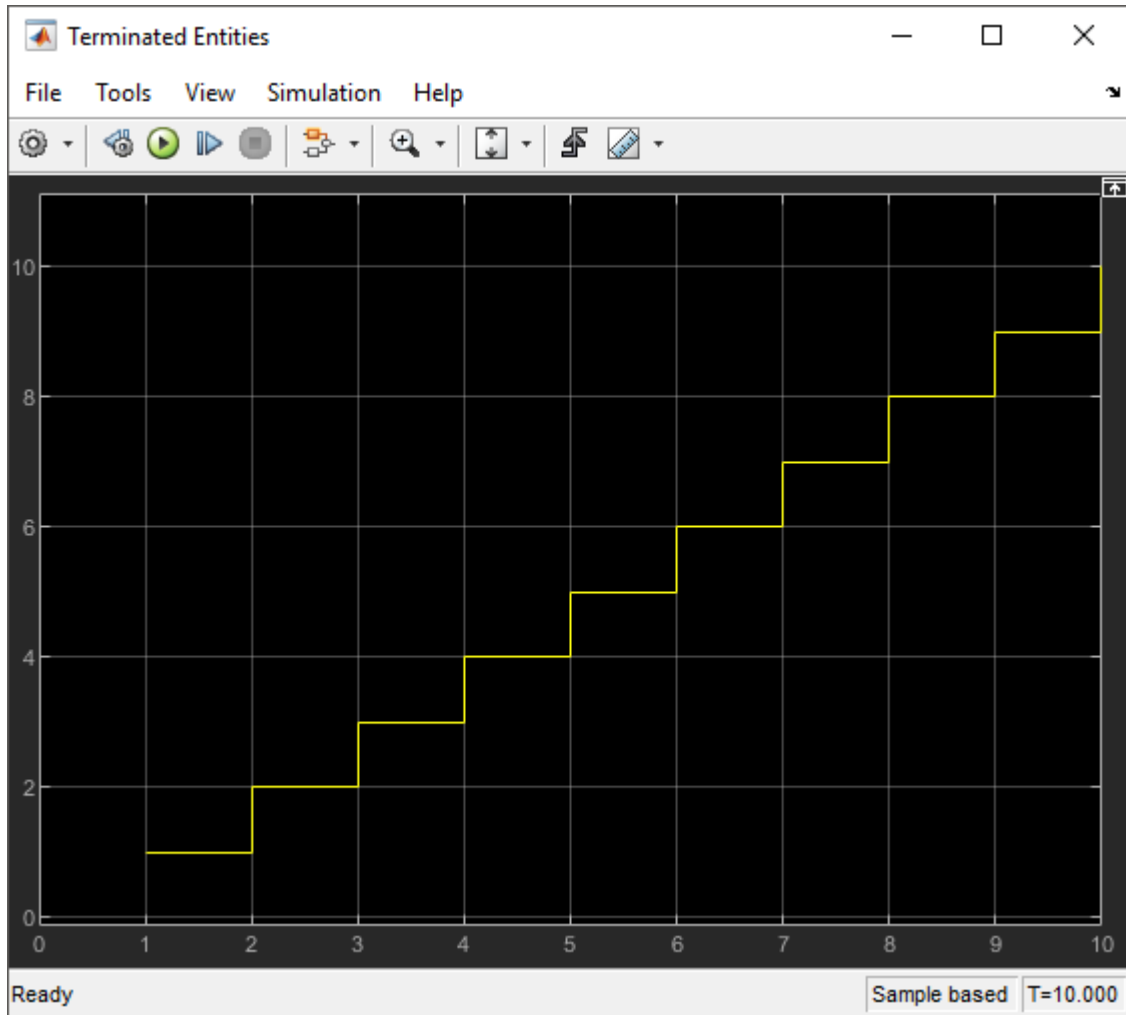

The Entity Find block finds entities with the Resource1 resource for every generated trigger entity.

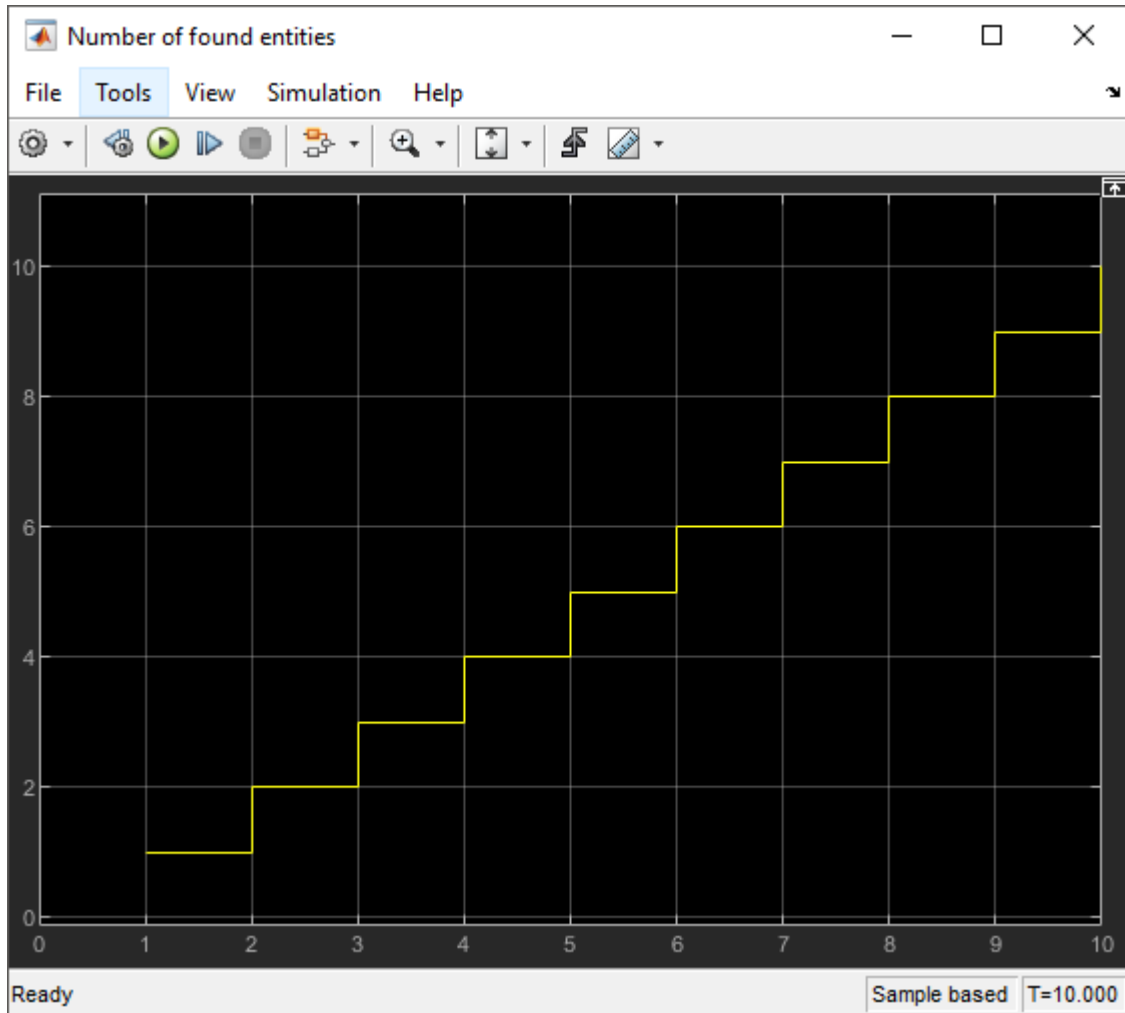

- 6 In the Entity Generator Block Parameters dialog box, in the **Generate action** field, add this code.

```
entity.Attribute1 = randi([1,2]);
```

The entities are generated with a random Attribute1 value 1 or 2.

- 7 In the Entity Find Block Parameters dialog box, select the **Additional filtering condition** check box. Add this code to replace any existing code and to set the filtering condition.

```
match = isequal(trigger.Attribute1, entity.Attribute1);
```

The block finds the entities that acquire the `Resource1` tag when the `match` is `true`. That is, the `Attribute1` value of an entity is equal to the trigger entity `Attribute1` value.

- 8 In the Trigger Entity Generator, observe that the `Attribute1` value is 1.
- 9 Simulate the model, observe that the number of found entities decreased to 3 because entities with the `Attribute1` value 2 are filtered out by the additional matching condition.

The trigger entity `Attribute1` value is 1. The block finds entities that acquire `Resource1` tag and have the `Attribute1` value 1.

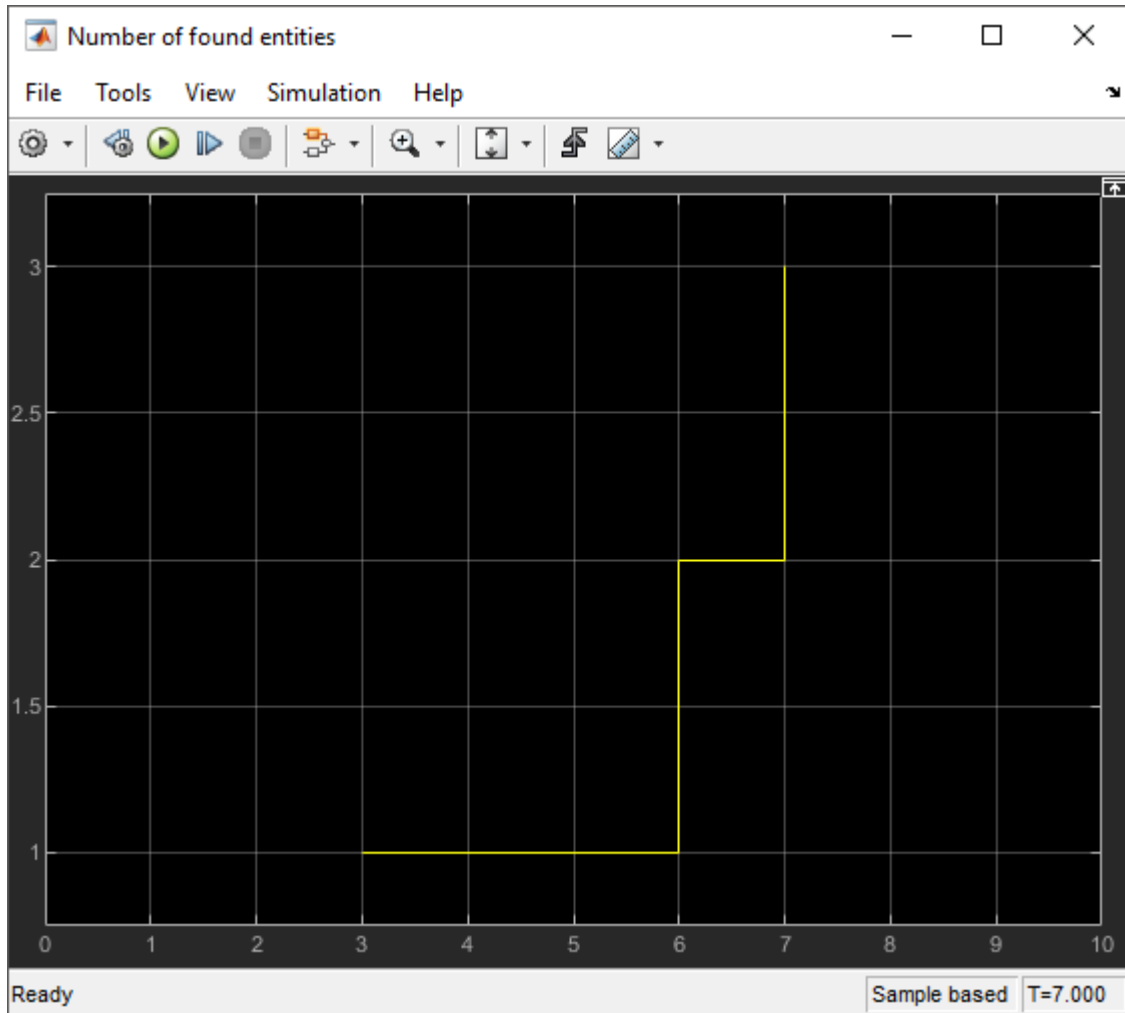

Extracting Found Entities

You can use the Entity Find block to find entities and extract them from their location to reroute. In this example, 3 entities found in the previous example are extracted from the system to be terminated.

To open the model, see [Extract Found Entities Example](#).

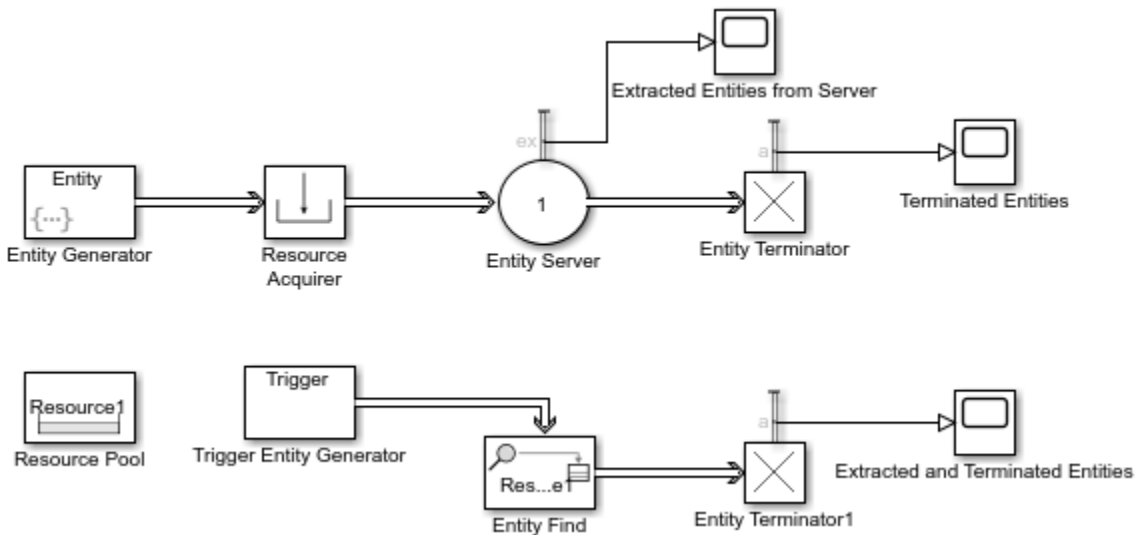

- 1 In the Entity Find Block Parameters dialog box, select the **Extract found entities** check box.
- Observe that a new output port appears at the Entity Find block for the extracted entities.
- 2 Connect the output of the Entity Find block to a new Entity Terminator1 block.
 - 3 Output the **Number of entities extracted, ex** statistic from the Entity Server block and connect it to a scope.

Visualize the number of extracted entities from the server.

- 4 Output the **Number of entities arrived, a** statistic from the Entity Terminator1 block and connect it to a scope.

The statistic is used to observe the number of found and extracted entities from the system.

- 5 Simulate the model. Observe that the **Number of entities extracted, ex** is 3.

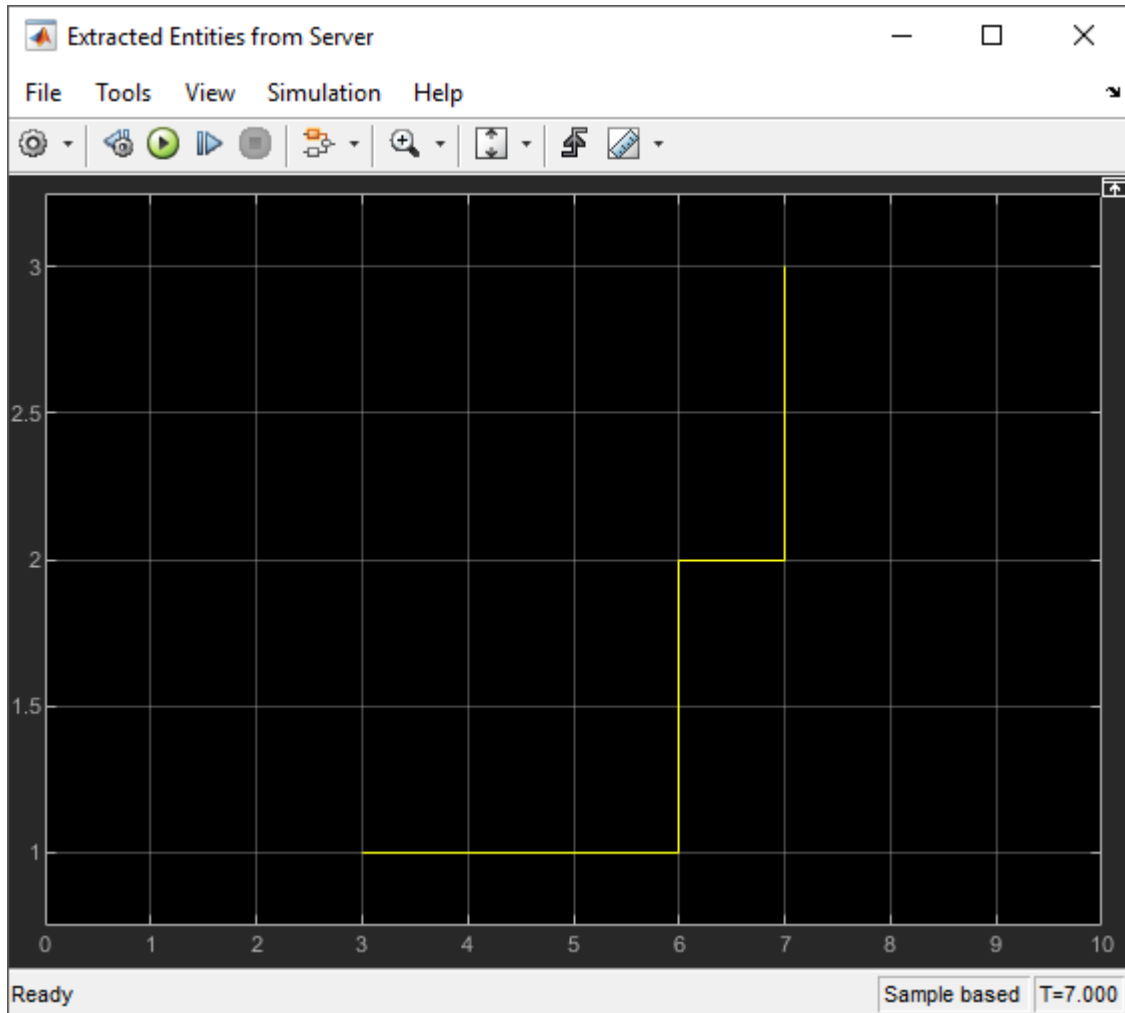

- 6 Observe that 3 found entities are extracted from the Entity Server block and terminated in the Entity Terminator1 block.

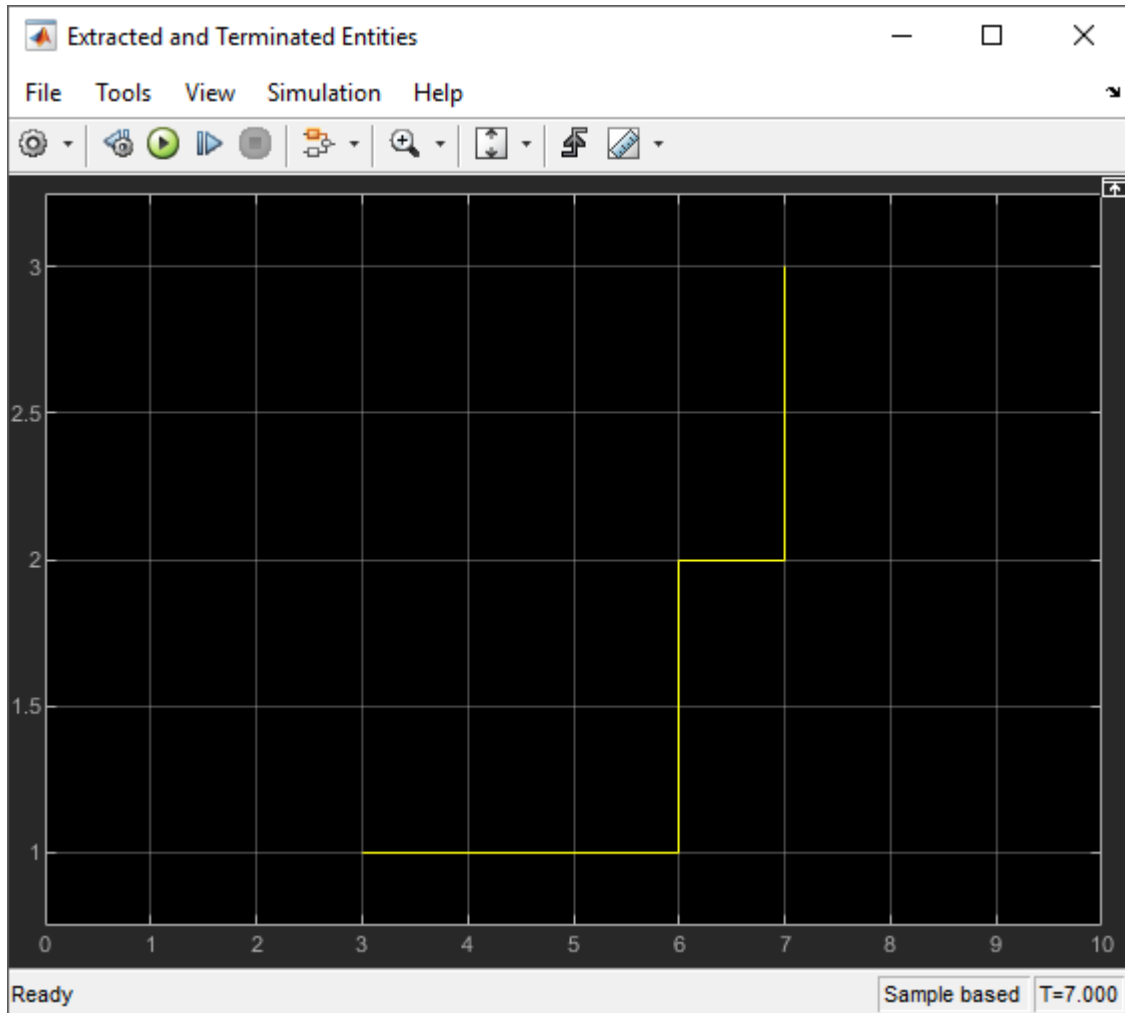

As a result, 7 entities arrive at the Entity Terminator block in the model.

Changing Found Entity Attributes

You can change the attributes of the found entities at their location or with extraction.

- 1 Change the attributes of found entities at their location by entering MATLAB code in the **OnFound** action field of the **OnFound** event action. For more information about events and event actions, see “Events and Event Actions” on page 1-2.
- 2 Change the attributes of found and extracted entities when they enter, exit, or are blocked by the Entity Find block. Enter MATLAB code in the **Entry** action, **Exit** action, and **Blocked** action, field of the **Event actions** tab.

Triggering Entity Find Block with Event Actions

You can trigger the Entity Find block with event actions. In this example, the Entity Find block is triggered when an entity enters the Entity Server block. Modify the previous example by removing the Trigger Entity Generator and by adding the Entity Output Switch, Entity Server1, Entity Terminator2 and Scope blocks to the model and connect them as shown.

To open the model, see [Trigger Entity Find Example](#).

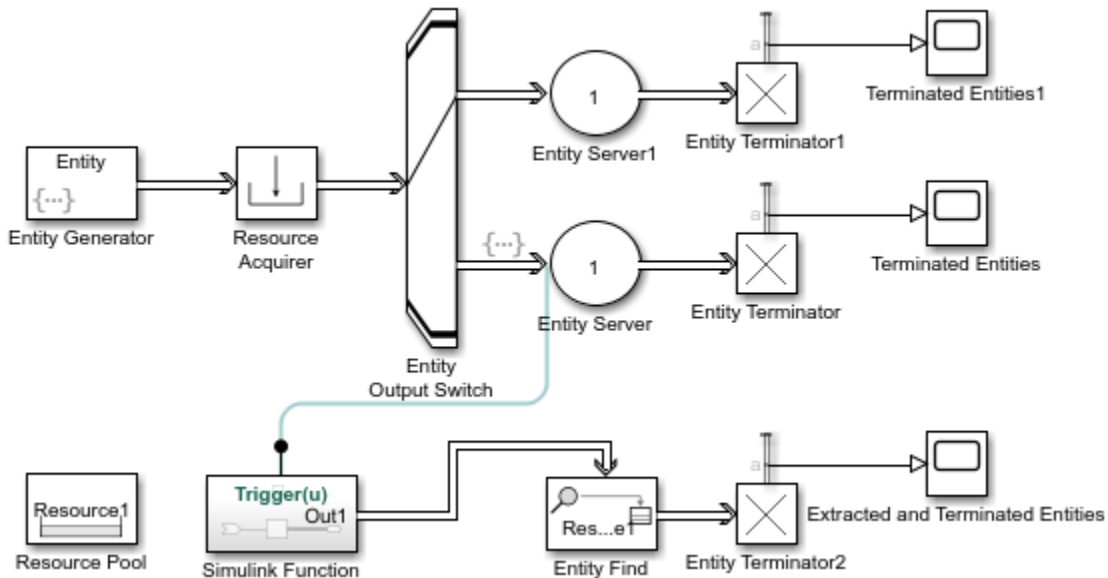

- 1 In the Entity Output Switch block, set the **Switching criterion** to Equiprobable.

Entities flow through the Entity Server and Entity Server1 blocks with equal probability.

- 2 Replace the Trigger Entity Generator block by a Simulink Function block to trigger Entity Find block. On the Simulink Function block, double-click the function signature and enter `Trigger(u)`.
- 3 In the Simulink Function block, add the Message Send block and connect it to an Out1 block.

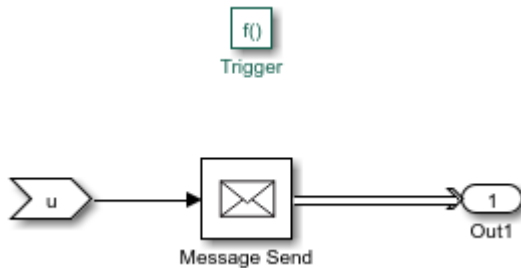

The `Trigger(u)` function call generates a message to trigger the Entity Find block every time an entity enters the Entity Server1 block.

- 4 In the Entity Server block, in the **Entry action** field, enter this code.

```
Trigger(double(1));
```

Every entity entry calls the `Trigger(u)` function in the Simulink Function block that triggers the Entity Find block.

- 5 In the Entity Find block, select the **Additional filtering condition** check box. Enter this code.

```
match = isequal(2, entity.Attribute1);
```

Found entities have the `Attribute1` value 2.

- 6 Simulate the model. Observe the scope that displays the extracted and terminated entities when the Entity Find block is triggered by the entity entry to the Entity Server block.

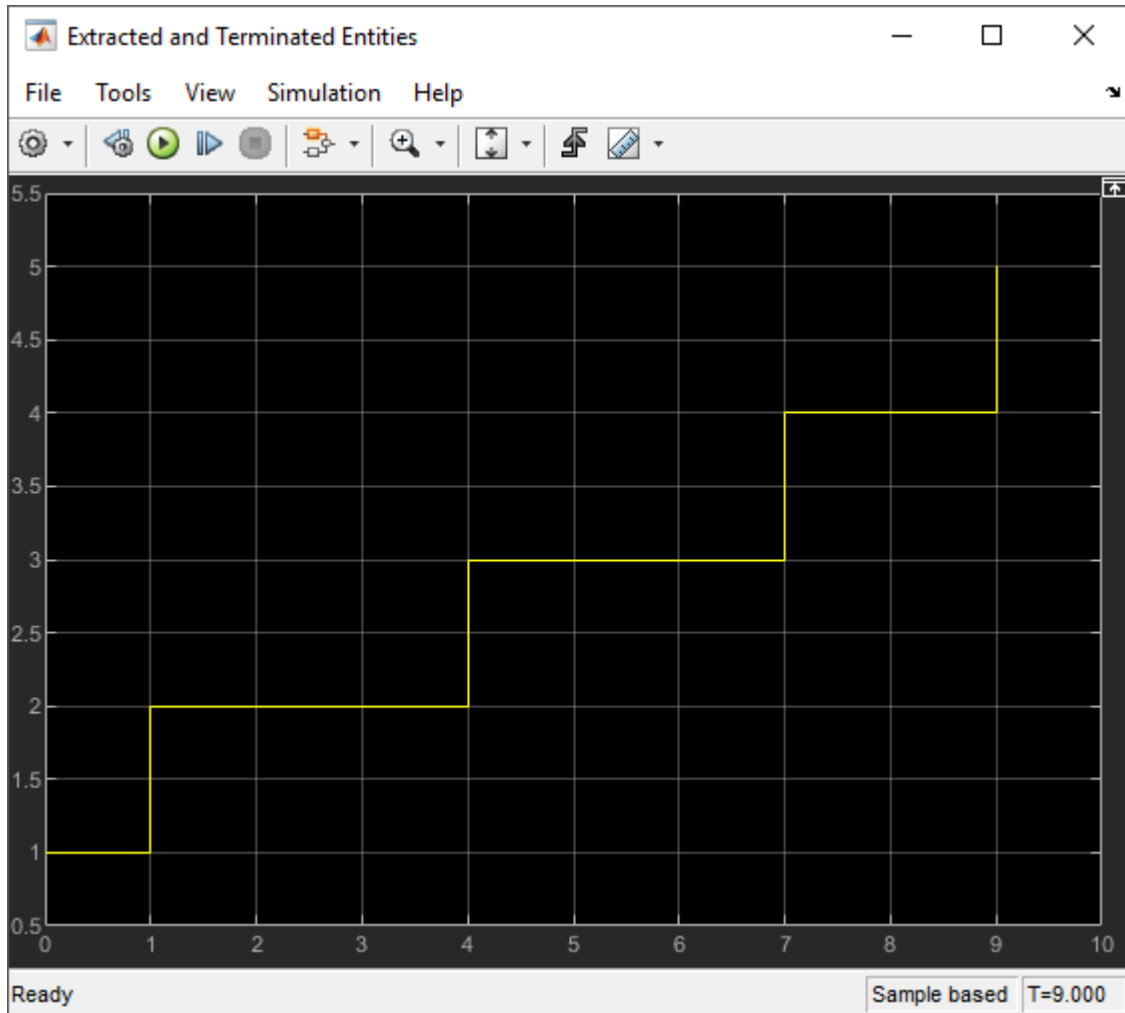

Building a Firewall and an Email Server

You can use the Entity Find block to monitor multiple blocks in a model to examine or extract entities and modify entity attributes.

This example represents an email server with a firewall to track, monitor, and discard harmful emails before they reach the user. In the model, emails arrive from the Internet

through an Entity Generator block. In the Firewall component, emails are classified as harmful for instant discarding, suspicious for monitoring, or safe based on their source. Harmful emails are tagged with a `DiscardTag` resource from the Resource Pool block and instantly discarded from the system. Suspicious emails are tagged with `MonitorTag` and tracked throughout the system for suspicious activity. If a suspicious activity is detected, the email is discarded before it reaches the user. Safe emails are not monitored or discarded.

To open the model, see [Email Monitoring Example](#).

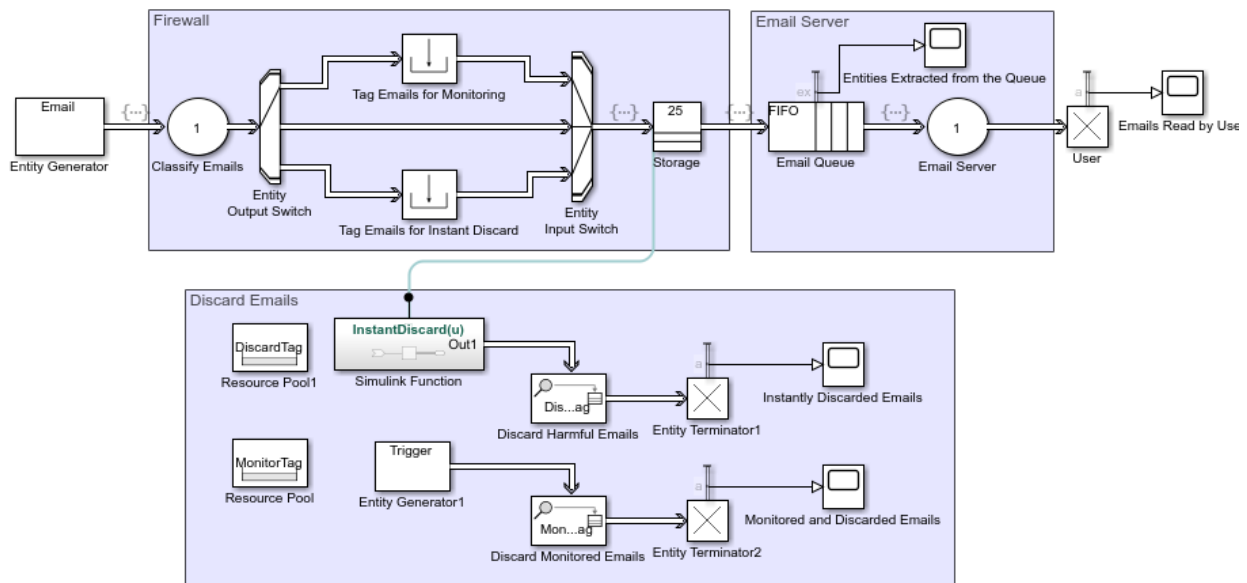

Build Firewall and Email Server Components

- 1 Add an Entity Generator block. In the block, set the **Entity type name** to `Email` and attach two attributes as `Source` and `Suspicious` with initial value `0`.
- 2 Add an Entity Server block. In the block, select the **Event actions** tab, and in the **Entry action** field enter this code.

```
entity.Source = randi([1,3]);
```

The `Source` attribute value is randomly generated and it is 1 for a suspicious, 2 for a safe, and 3 for a harmful email source.

- 3 Add an Entity Output Switch block. In the block, set the **Number of output ports** to 3, the **Switching criterion** to From attribute, and the **Switch attribute name** to Source.
- 4 Add two Resource Pool blocks and set their **Resource name** parameters to MonitorTag and DiscardTag.
- 5 Add a Resource Acquirer block labeled Tag Emails for Monitoring. In the block, select MonitorTag as **Selected Resources**.
- 6 Add another Resource Acquirer block labeled Tag Emails for Instant Discard. In the block, select DiscardTag as **Selected Resources**.
- 7 Add an Entity Input Switch block. In the block, set the **Number of input ports** to 3.
- 8 Add an Entity Store block. In the block, select the **Event actions** tab, and in the **Entry action** field enter this code.

```
InstantDiscard(1);
entity.Suspicious = randi([1,2]);
```

- 9 Add an Entity Queue block. In the block, select the **Event actions** tab, and in the **Entry action** field enter this code.

```
entity.Suspicious = randi([1,2]);
```

The Suspicious attribute of an email changes in the entry. If the Suspicious attribute value is 2, the email is extracted and terminated. This represents the randomly observed suspicious activity in the system.

- 10 Add another Entity Server block. In the block, set the **Service time value** to 3, select the **Event actions** tab, in the **Entry action** field, enter this code.

```
entity.Suspicious = randi([1,2]);
```

- 11 Add an Entity Terminator block labeled Emails Read by User, and connect all the blocks as shown in the model.

Monitor and Discard Emails with Entity Find Block

- 1 Add a Simulink Function block.
 - a Double-click the function signature on the Simulink Function block and enter InstantDiscard(u).
 - b Double-click the Simulink Function block. Add a Message Send block and an Out1 block.

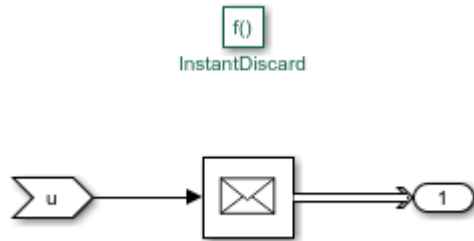

- 2 In the parent model, add an Entity Find block. In the block, set **Resource** to DiscardTag and select **Extract found entities** check box.

Any email entry calls the `InstantDiscard()` function and triggers the Entity Find block to find and discard harmful emails.

- 3 Add another Entity Terminator block labeled Instantly Discarded Emails.
- 4 Add another Entity Find block. In the block, set the **Resource** to MonitorTag and select the **Extract found entities** and the **Additional filtering condition** check boxes. In the **Matching condition** field, enter this code.

```
match = isequal(trigger.Attribute1, entity.Suspicious);
```

- 5 Add another Entity Generator block labeled Entity Generator1. In the block, set the **Period** to 5, the **Entity priority** to 100, the **Entity type name** to Trigger, and the **Attribute Initial Value** to 2.
- 6 Add another Entity Terminator block labeled Monitored and Discarded Emails. Connect all the blocks as shown in the model.
- 7 Output the **Number of entities arrived**, a statistic from all of the Entity Terminator blocks, and connect them to the Scope blocks for visualization.
- 8 Increase the simulation time to 50 and simulate the model. Observe the emails that are instantly discarded or discarded after monitoring.

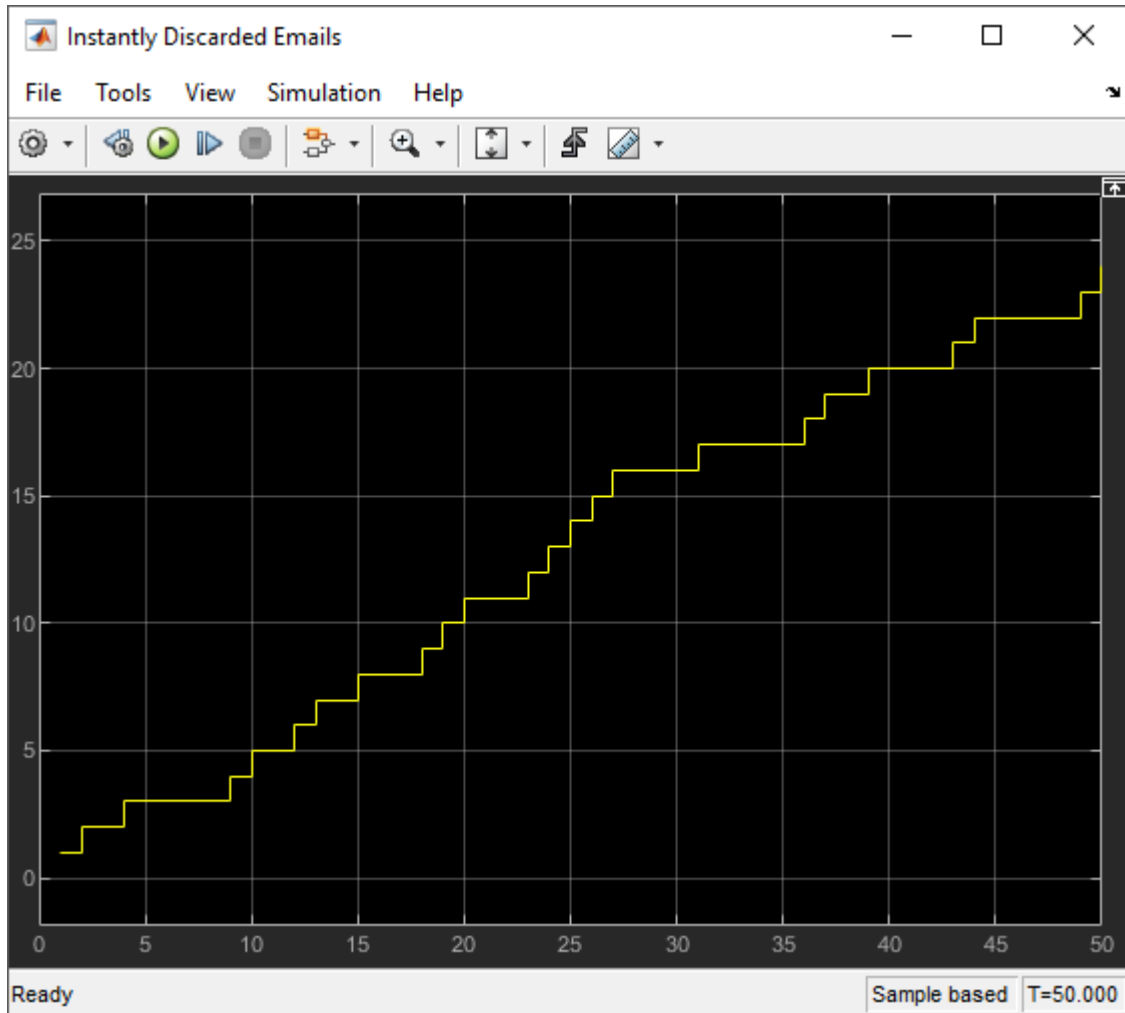

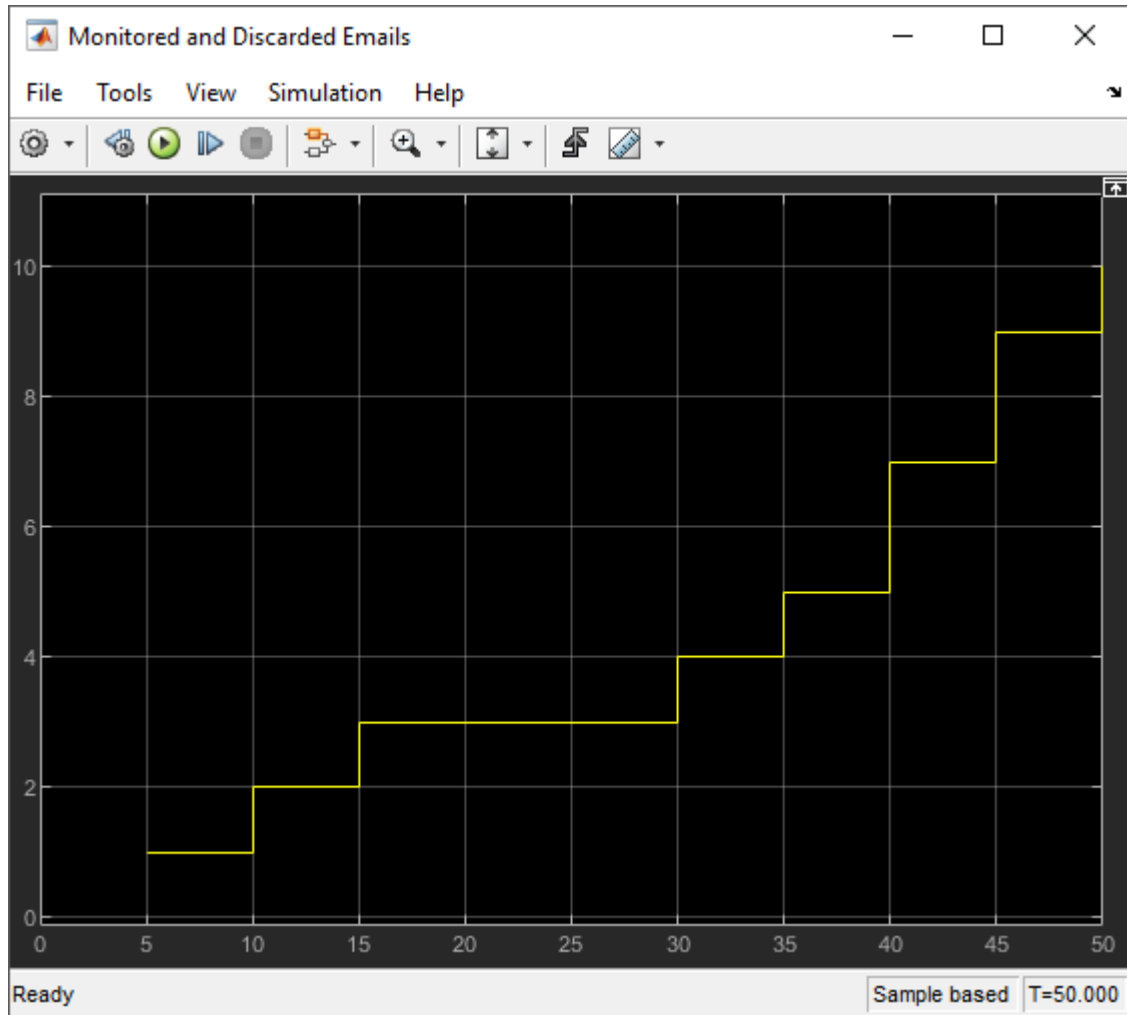

Observe the emails that reach the user after the filtering.

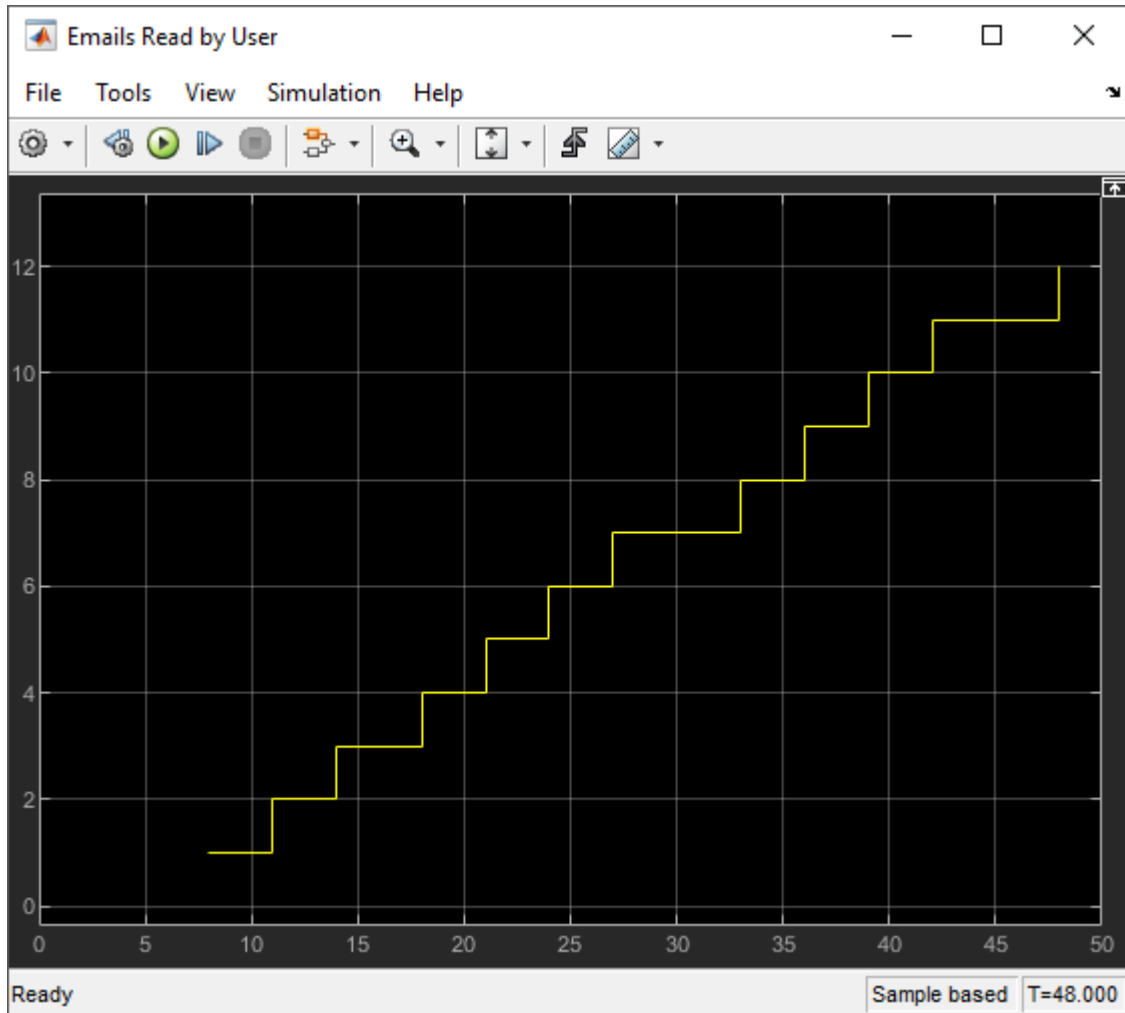

- Optionally, visualize the number of extracted emails from any block in the model. For instance, in the Email Queue, select the **Number of entities extracted, ex** statistic and connect to a scope. Observe that six emails are extracted from the queue.

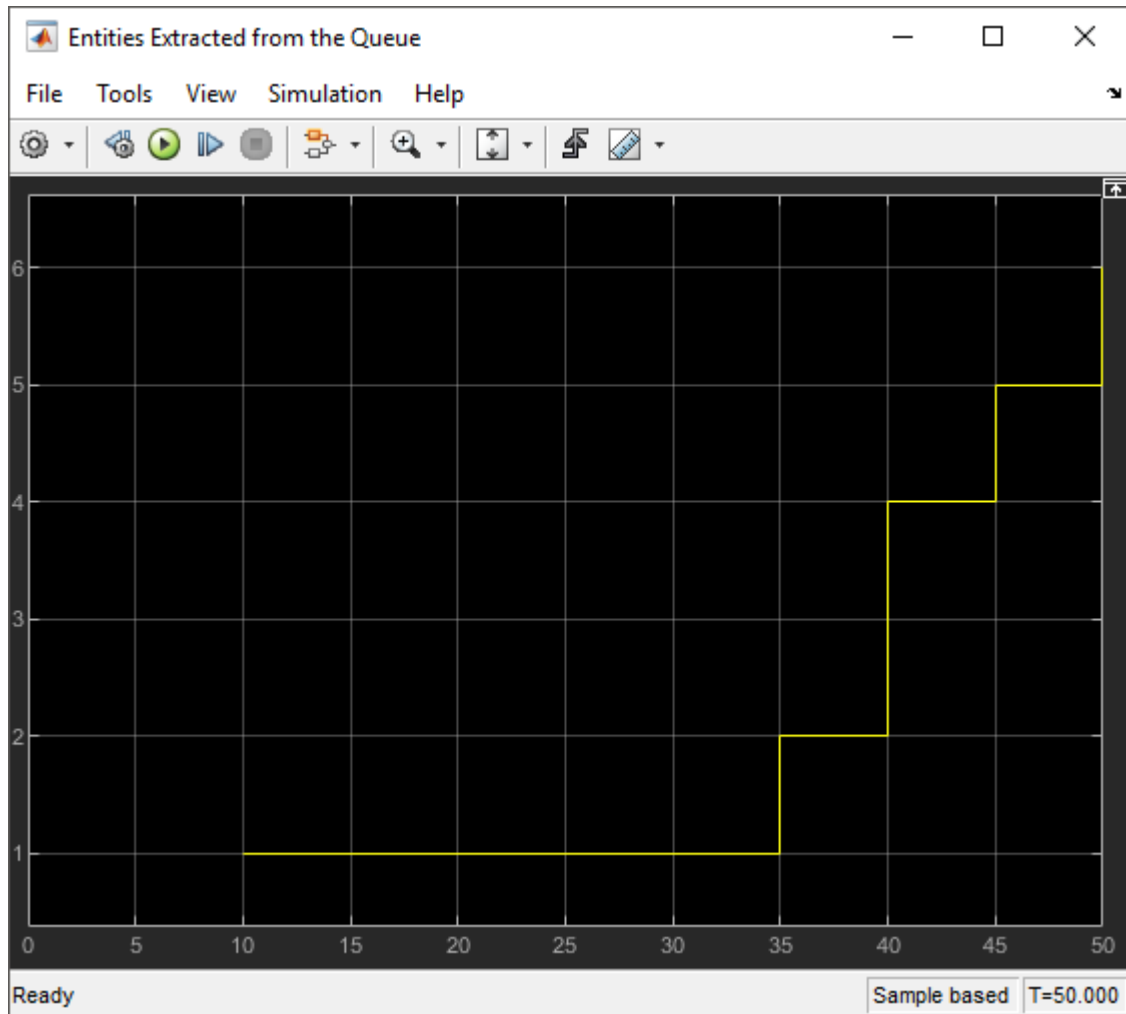

See Also

Resource Acquirer | Resource Pool | Resource Releaser

Related Examples

- “Optimize SimEvents Models by Running Multiple Simulations” on page 5-26

More About

- “Model Using Resources” on page 4-2
- “Set Resource Amount with Attributes” on page 4-4

Visualization, Statistics, and Animation

- “Interpret SimEvents Models Using Statistical Analysis” on page 5-2
- “Visualization and Animation for Debugging” on page 5-14
- “Model Traffic Intersections as a Queuing Network” on page 5-17
- “Optimize SimEvents Models by Running Multiple Simulations” on page 5-26
- “Use the Sequence Viewer Block to Visualize Messages, Events, and Entities” on page 5-32

Interpret SimEvents Models Using Statistical Analysis

In this section...

“Output Statistics for Data Analysis” on page 5-2
“Output Statistics for Run-Time Control” on page 5-2
“Average Queue Length and Average Store Size” on page 5-6
“Average Wait” on page 5-9
“Number of Entities Arrived” on page 5-11
“Number of Entities Departed” on page 5-11
“Number of Entities Extracted” on page 5-12
“Number of Entities in Block” on page 5-12
“Number of Pending Entities” on page 5-12
“Pending Entity Present in Block” on page 5-12
“Utilization” on page 5-12

Choosing the right statistical measure is critical for evaluating the model performance. You can use output statistics from the SimEvents library blocks for data analysis and run-time control.

Output Statistics for Data Analysis

Consider these statistical measures for more efficient behavior interpretation.

- Identify the appropriate size of the samples to compute more meaningful statistics.
- Decide if you want to investigate the transient behavior, the steady-state behavior, or both.
- Specify the number of simulations that ensures sufficient confidence in the results.

For an example, see “Explore Statistics and Visualize Simulation Results”.

Output Statistics for Run-Time Control

Some systems rely on statistics to influence the dynamics. In this example, a queuing system with discouraged arrivals has a feedback loop that adjusts the arrival rate throughout the simulation based on the statistics reported by the queue and the server. To

learn more details about this example, see “Adjust Entity Generation Times Through Feedback” on page 1-26.

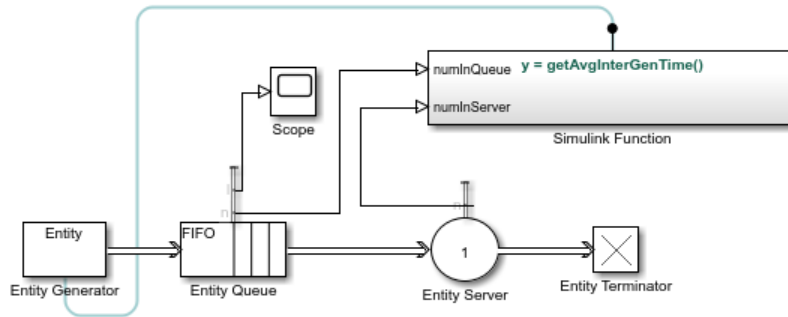

A subset of the blocks in SimEvents library provides statistics output for run-time control. When you create simulations that use statistical signals to control the dynamics, you access the current statistical values at key times throughout the simulation, not just at the end of the simulation.

This table lists SimEvents blocks that output commonly used statistics for data analysis and run-time control.

Block Name	Statistics Parameter								
	Average queue length/store size, l	Average wait, w	Number of entities arrived, a	Number of entities departed, d	Number of entities extracted, ex	Number of entities in block, n	Number of pending entities, np	Pending entity present in block, pe	Utilization, util
Conveyor System				✓		✓		✓	
Entity Batch Creator			✓	✓				✓	

Block Name	Statistics Parameter								
	Average queue length/store size, l	Average wait, w	Number of entities arrived, a	Number of entities departed, d	Number of entities extracted, ex	Number of entities in block, n	Number of pending entities, np	Pending entity present in block, pe	Utilization, util
Entity Batch Splitter			✓	✓				✓	
Entity Find	✓	✓		✓	✓				
Entity Generator				✓				✓	
Entity Queue	✓	✓		✓	✓	✓			
Entity Selector				✓	✓	✓			
Entity Server		✓		✓	✓	✓	✓	✓	✓
Entity Store	✓	✓		✓	✓	✓			
Entity Terminator			✓						
Multicast Receive Queue	✓	✓		✓	✓	✓			

Block Name	Statistics Parameter								
	Average queue length/store size, l	Average wait, w	Number of entities arrived, a	Number of entities departed, d	Number of entities extracted, ex	Number of entities in block, n	Number of pending entities, np	Pending entity present in block, pe	Utilization, util
Resource Acquirer		✓		✓	✓	✓			
Resource Pool									✓

The statistical parameters are updated on particular events during the simulation. For example, when a full N-server advances one entity to the next block, the statistical signal representing the number of entities in the block assumes the value N-1. However, if the departure causes another entity to arrive at the block at the same time instant, then the statistical signal assumes the value N. The value of N-1, which does not persist for a positive duration, is a zero-duration value.. This phenomenon occurs in many situations.

This table lists the events that update the block statistics.

Statistics Port	Updated on Event				
	Entry	Exit	Blocked	Preempted	Extracted
Average queue length/store size, l	✓	✓			✓
Average wait, w		✓		✓	✓
Number of entities arrived, a	✓				
Number of entities departed, d		✓			✓

Statistics Port	Updated on Event				
	Entry	Exit	Blocked	Preempted	Extracted
Number of entities extracted, ex					✓
Number of entities in block, n	✓				✓
Number of pending entities, np		✓	✓	✓	
Pending entity present in block, pe		✓	✓	✓	
Utilization, util	✓	✓		✓	✓

Average Queue Length and Average Store Size

The formula to compute average queue length or store size

Average queue length, l is the accumulated time-weighted average queue. To compute **Average queue length, l** at time t_f , the block:

- 1 Multiplies the size of the queue n by its duration, $t = t_i - t_{i-1}$, to calculate the time-weighted queue.
- 2 Sums over the time-weighted queue and averages it over total time t_f .

$$l = \frac{1}{t_f} \sum_{i=1}^f n_t \times t$$

Where:

- t is the time between the entity arrival and / or the number of departure events.
- f is the total number of entity arrival and / or the number of departure events between t_0 and t_f .

- $i = 1$ for simulation time $t_0 = 0$.

Average store size, I is computed similarly by replacing the queue length with the store size.

Average queue length example in the Entity Queue block

This example shows the average queue length of the entities in the Entity Queue block.

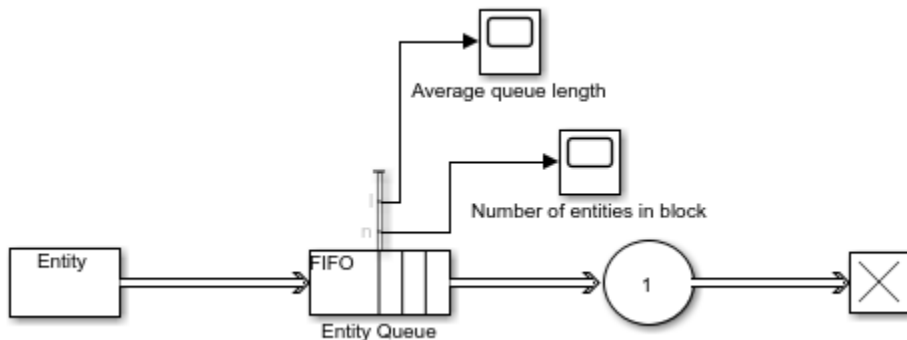

Calculate average queue length in the simple queuing system example

The service time for the Entity Server block is larger than the entity intergeneration time of the Entity Generator block. The entities are queued and sorted in the Entity Queue block. The scope displays the number of entities.

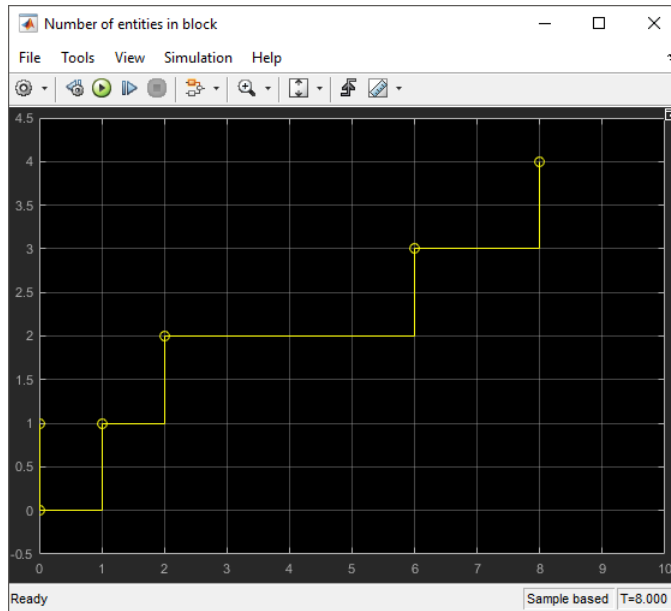

For the duration between 0 and 1, the average queue length is 0 because the size of the queue is 0. Between 1 and 2 the queue length is 1. Average queue length at time $t_f = 2$ is calculated as follows.

$$l = \frac{1}{2} \sum_{i=1}^2 n_t \times t = \frac{1}{2}(0 + 1 \times 1) = 0.5$$

The queue size is 2 between the times 2 and 6 for the duration of 4. Average queue length at time $t_f = 6$ is calculated using this equation.

$$l = \frac{1}{6} \sum_{i=1}^6 n_t \times t = \frac{1}{6}(0 + 1 \times 1 + 2 \times 4) = 1.5$$

The average queue size is calculated for each duration. The Scope block displays its value for the duration of the simulation.

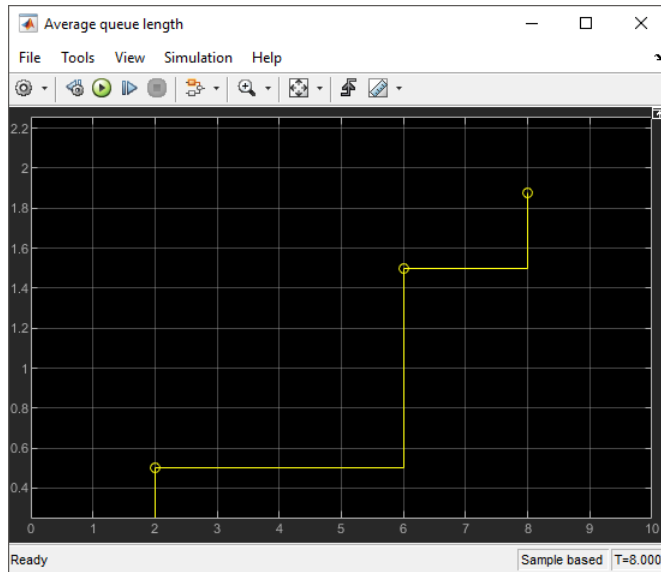

Average Wait

The formula to compute average wait

The **Average wait**, w parameter represents the sum of the wait times for entities departing the block, divided by their total number, n .

Wait time, w_j , is the simulated time that an entity resides within a block. This wait time is not necessarily equivalent to the time an entity is blocked. It is the duration between an entity's entry into and exit from a block. For instance, wait time is 1 for an entity that travels through an unblocked Entity Server with a service time of 1s.

$$w = \frac{\sum_{j=1}^n w_j}{n}$$

Average wait of entities example in the Entity Server block

This example shows the average wait time for entities that are served in the Entity Server block.

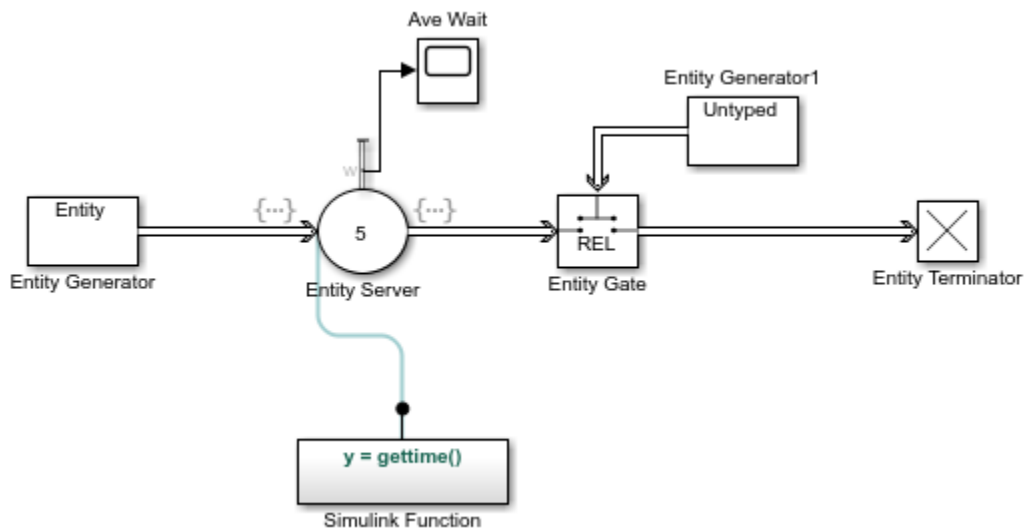

Calculate average wait in the example

The duration of an entity's entry into and exit from the Entity Server block is computed by the `gettime()` function in the Simulink Function block.

The Diagnostic Viewer displays the duration between the entry and exit of six consecutive entities.

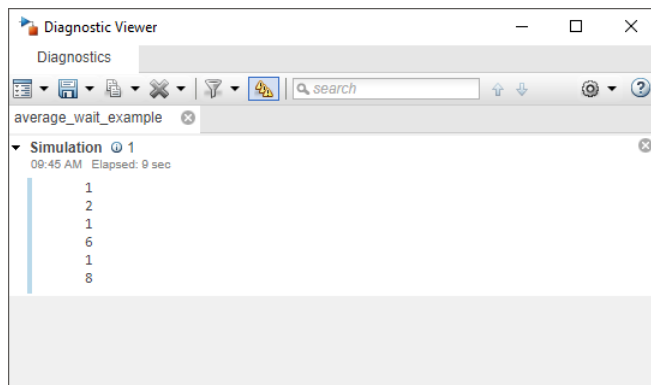

The Scope block shows the average wait time for each entity departure event from the Entity Server block. For instance, the wait time for the first entity is 1 and the wait time for the second entity is 2. The average wait time calculated for the first two entities is 1.5. The plot displays this value at the simulation time 6. For the first four entities, the sum of the wait times is 10 and the average wait time at simulation time 12 becomes 2.5. For the first five entities, the sum of the wait times is 15 and the average wait time at simulation time 18 becomes 3.

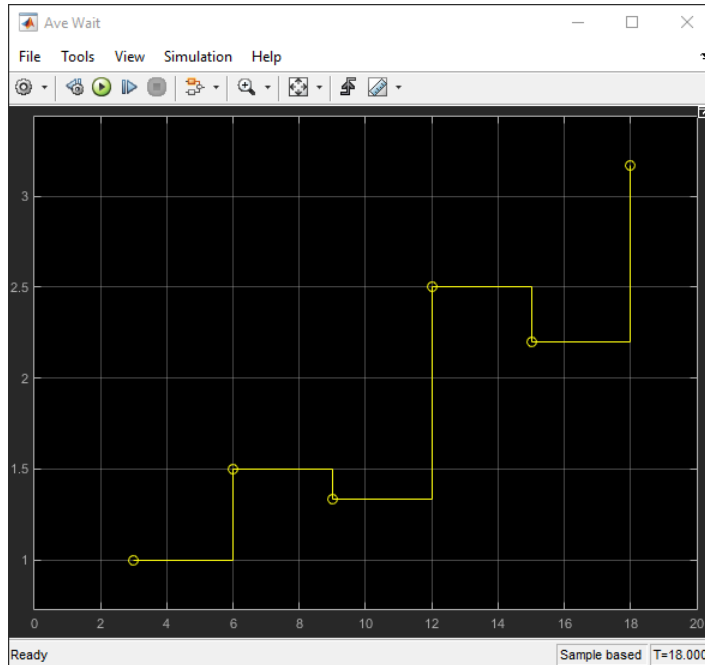

Number of Entities Arrived

The **Number of entities arrived**, **a** parameter outputs the cumulative count for the number of entities that arrive at the block.

Number of Entities Departed

The **Number of entities departed**, **d** parameter outputs the cumulative count for the number of entities that depart the block.

Number of Entities Extracted

Entity Find block finds entities in a SimEvents model and extracts them from their location to reroute. The **Number of entities extracted**, **ex** parameter outputs the number of entities that are extracted from a block.

Number of Entities in Block

The **Number of entities in block**, **n** parameter outputs the number of entities that are in the block.

Number of Pending Entities

The **Number of pending entities**, **np** parameter outputs the number of pending entities the block has served that have yet to depart.

Pending Entity Present in Block

The **Pending entity present in block**, **pe** parameter indicates whether an entity that is yet to depart is present in the block. The value is 1 if there are any pending entities, and 0 otherwise.

Utilization

The **Utilization**, **util** parameter indicates the average time a block is occupied. The block calculates utilization for each entity departure event, which is the ratio of the total wait time for entities to the server capacity, C , multiplied by the total simulation time, t_f . Utilization for n entities is calculated using this equation.

$$util = \frac{\sum_{j=1}^n w_j}{C \times t_f}$$

References

- [1] Cassandras, Christos G. *Discrete Event Systems: Modeling and Performance Analysis*. Homewood, Illinois: Irwin and Aksen Associates, 1993.

See Also

Entity Generator | Entity Queue | Entity Server | Entity Terminator | Multicast Receive Queue | Resource Acquirer

More About

- *“Count Entities”*
- *“Visualization and Animation for Debugging”* on page 5-14
- *“Explore Statistics and Visualize Simulation Results”*

Visualization and Animation for Debugging

In this section...

“Which Debugging Tool to Use” on page 5-14

“Observe Entities with Animation” on page 5-15

“Explore the System Using the Simulink Simulation Stepper” on page 5-15

“Information About Race Conditions and Random Times” on page 5-16

Visualize and animate simulations in SimEvents models using tools available in Simulink and SimEvents software.

- You can place many Simulink Sink blocks directly on the entity line to observe entities, including the To Workspace and dashboard scopes.
- If the entity type is anonymous, you can place a Scope block.
- To observe bus or structured type entities, use the Simulation Data Inspector or dashboard scopes. The Scope and Display blocks do not support buses.

Which Debugging Tool to Use

These tools help you explore various elements of a SimEvents model.

Items to Observe	Visualization Tool and Its Purpose
Statistics	<ul style="list-style-type: none"> • Simulation Data Inspector — Show the statistic throughout the simulation. For more information, see “Inspect and Analyze Simulation Results” (Simulink). • Simulink To Workspace block — Write the data set to the MATLAB workspace when the simulation stops or pauses. • Simulink Scope block — Create a plot using the statistic. • Simulink Display block — Show the statistic throughout the simulation. • Simulink To File block — Write the data set into a MAT-file. • Simulink Dashboard Scope block — Create a plot using the statistic.
Entities passing through model	
Entity animation	Animation — Highlight active entities in the simulation.

Items to Observe	Visualization Tool and Its Purpose
Step of a Simulation	Simulink Simulation Stepper — Step forward and back through a simulation. For more information, see “Use Simulation Stepper” (Simulink).
Custom animation	Use SimEvents custom visualization API — Create custom observers of the entities and events in a model. For more information, see “Use SimulationObserver Class to Monitor a SimEvents Model” on page 10-2.

Note The Simulink Floating Scope does not support SimEvents models.

Simulation Data Inspector is a unified user interface for viewing both entities and signal (for example, statistics) data. For more information, see “Inspect and Analyze Simulation Results” (Simulink).

Observe Entities with Animation

During simulation, animation provides visual verification that your model behaves as you expect. Animation highlights active entities in a model as execution progresses. You can control the speed of entity activity animation during simulation, or turn off animation. In a model window, right-click and select **Animation Speed**.

- **Fast**
- **Medium**
- **Slow**
- **None**

The **Fast** animation speed shows the active highlights at each time step. To add delay with each time step, set the animation speed to **Medium** or **Slow**. To turn off the animation, select **None**.

Explore the System Using the Simulink Simulation Stepper

Simulation Stepper enables you to step through major time steps of a simulation. Use this tool to explore your discrete-event system. For more information, see “Simulation Stepper” (Simulink).

Information About Race Conditions and Random Times

You can vary the processing sequence for simultaneous events or make the intergeneration times or service times random.

See Also

Entity Generator | Entity Queue | Entity Server | Entity Terminator | Multicast Receive Queue | Resource Acquirer

More About

- “Explore Statistics and Visualize Simulation Results”
- “Count Entities”

Model Traffic Intersections as a Queuing Network

This example shows how to create a SimEvents® model to represent a vehicle traffic network and to investigate mean waiting time of vehicles when the network is in steady-state.

Suppose a vehicle traffic network consists of two vehicle entry and two vehicle exit points, represented by brown and green nodes in the next figure. Each blue node in the network represents a route intersection with a traffic light, and the arrows represent the route connections at each intersection. The values next to the arrows represent the percentage of vehicles taking the route in that intersection.

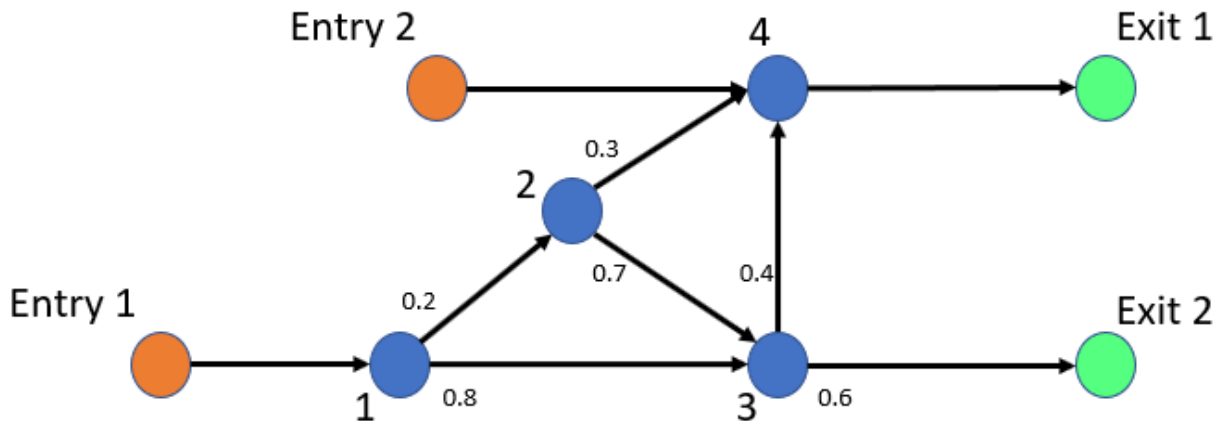

The rate of vehicle entries into the network are represented by the Poisson processes with rates 0.5 for Entry 1 and 0.15 for Entry 2. Service rates represent the time vehicles spend at each intersection, which are drawn from exponential distribution with mean 1. The arrow values are the probabilities of choosing a route for vehicles in the intersection.

Model Traffic Network

To represent a vehicle traffic network, this model uses Entity Generator, Entity Server, Entity Queue, Entity Input Switch, Entity Output Switch, and Entity Terminator blocks.

```

model = 'QueueServerTransportationNetwork';
open_system(model);
  
```

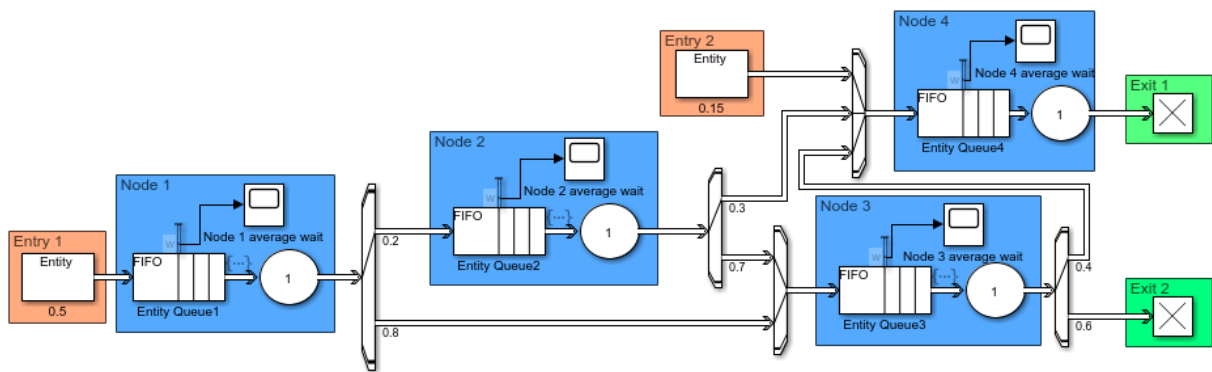

Copyright 2019 The MathWorks, Inc.

Model Vehicle Arrivals

The two Entity Generator blocks represent the network entry points. Their entity intergeneration time is set to create a Poisson arrival process.

This is the code in the **Intergeneration time action** field of the Entry 1 block.

```
% Random number generation
coder.extrinsic('rand');
ValEntry1 = 1;
ValEntry1 = rand();
% Pattern: Exponential distribution
mu = 0.5;
dt = -1/mu * log(1 - ValEntry1);
```

In the code, μ is the Poisson arrival rate. The `coder.extrinsic('rand')` is used because there is no unique seed assigned for the randomization. For more information about random number generation in event actions, see “Event Action Languages and Random Number Generation” on page 1-5. To learn more about extrinsic functions, see “Working with mxArray” (Simulink).

Model Vehicle Route Selection

Entities have a `Route` attribute that takes value 1 or 2. The value of the attribute determines the output port from which the entities depart an Entity Output Switch block.

This code in the **Entry action** of the Entity Server 1 represents the random route selections of vehicles at the intersection represented by Node 1.

```

Coin1 = 1;
coder.extrinsic('rand');
Coin1 = rand;
if Coin1 <= 0.2
    entity.Route = 1;
else
    entity.Route = 2;
end

```

This is an example of random `Route` attribute assignments when entities enter the Entity Server 1 block. The value of `Route` is assigned based on the value of the random variable `rand` that takes values between 0 and 1. `Route` becomes 1 if `rand` is less than or equal to 0.2, or 2 if `rand` is greater than 0.2.

Model Route Intersections

Each blue node represents a route intersection and includes an infinite capacity queue, and a server with service time drawn from an exponential distribution with mean 1.

Entity Server 1 contains this code.

```

% Pattern: Exponential distribution
coder.extrinsic('rand');
Val1 = 1;
Val1 = rand();
mu = 1;
dt = -mu * log(1 - Val1);

```

Calculate Mean Waiting Time for Vehicles in the Network

The network is constructed as an open Jackson network that satisfies these conditions.

- All arriving vehicles can exit the network.
- Vehicle arrivals are represented by Poisson process.
- Vehicles depart an intersection as first-in first-out. The wait time in an intersection is exponentially distributed with mean 1.
- A vehicle departing the intersection either takes an available route or leaves the network.
- The utilization of each traffic intersection queue is less than 1.

In the steady state, every queue in an open Jackson network behaves independently as an M/M/1 queue. The behavior of the network is the product of individual queues in

equilibrium distributions. For more information about M/M/1 queues, see “M/M/1 Queuing System”.

The vehicle arrival rate for each node i is calculated using this formula.

$$\lambda_i = r_i + \sum_{j=1}^N \theta_{ji} \lambda_j,$$

In the formula:

- r_i is the rate of external arrivals for node i .
- $j = 1, \dots, N$ is the total number of incoming arrows to node i .
- θ_{ji} is the probability of choosing the node i from node j .
- λ_j is the total vehicle arrival rate to node j .

For all of the nodes in the network, the equation takes this matrix form.

$$\lambda = R(I - \theta)^{-1}$$

Here, θ is the routing matrix, and each element represents the probability of transition from node j to node i .

For the network investigated here, this is the routing matrix.

$$\theta = \begin{bmatrix} 0 & 0.2 & 0.8 & 0 \\ 0 & 0 & 0.7 & 0.3 \\ 0 & 0 & 0 & 0.4 \\ 0 & 0 & 0 & 0 \end{bmatrix}$$

R is the vector of external arrivals to each node.

$$R = [0.5 \quad 0 \quad 0 \quad 0.15]$$

Using these values, the mean arrival rate is calculated for each node.

$$\lambda = [0.5 \quad 0.1 \quad 0.47 \quad 0.368]$$

Each node behaves as an independent M/M/1 queue, and the mean waiting time for each node i is calculated by this formula. See “M/M/1 Queuing System”.

$$\rho_i = \frac{\lambda_i}{1-\lambda_i}$$

Mean waiting time for each node is calculated by incorporating each element of λ .

$$\rho = [1 \quad 0.11 \quad 0.88 \quad 0.58]$$

View Simulation Results

Simulate the model and observe that the mean waiting time in each queue in the network matches the calculated theoretical results.

- The waiting time for the queue in node 1 converges to 1.

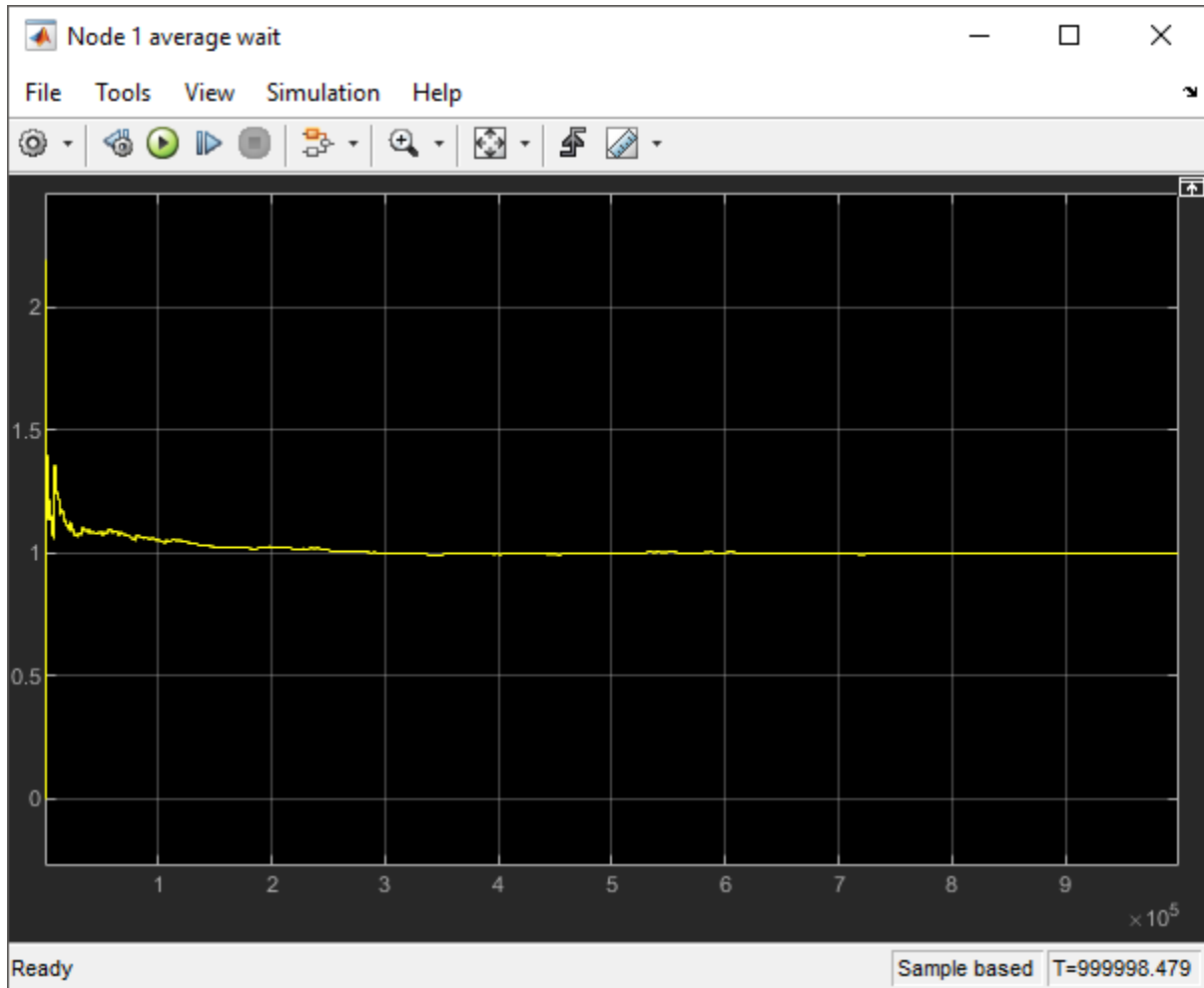

- The waiting time for the queue in node 2 converges to 0.11.

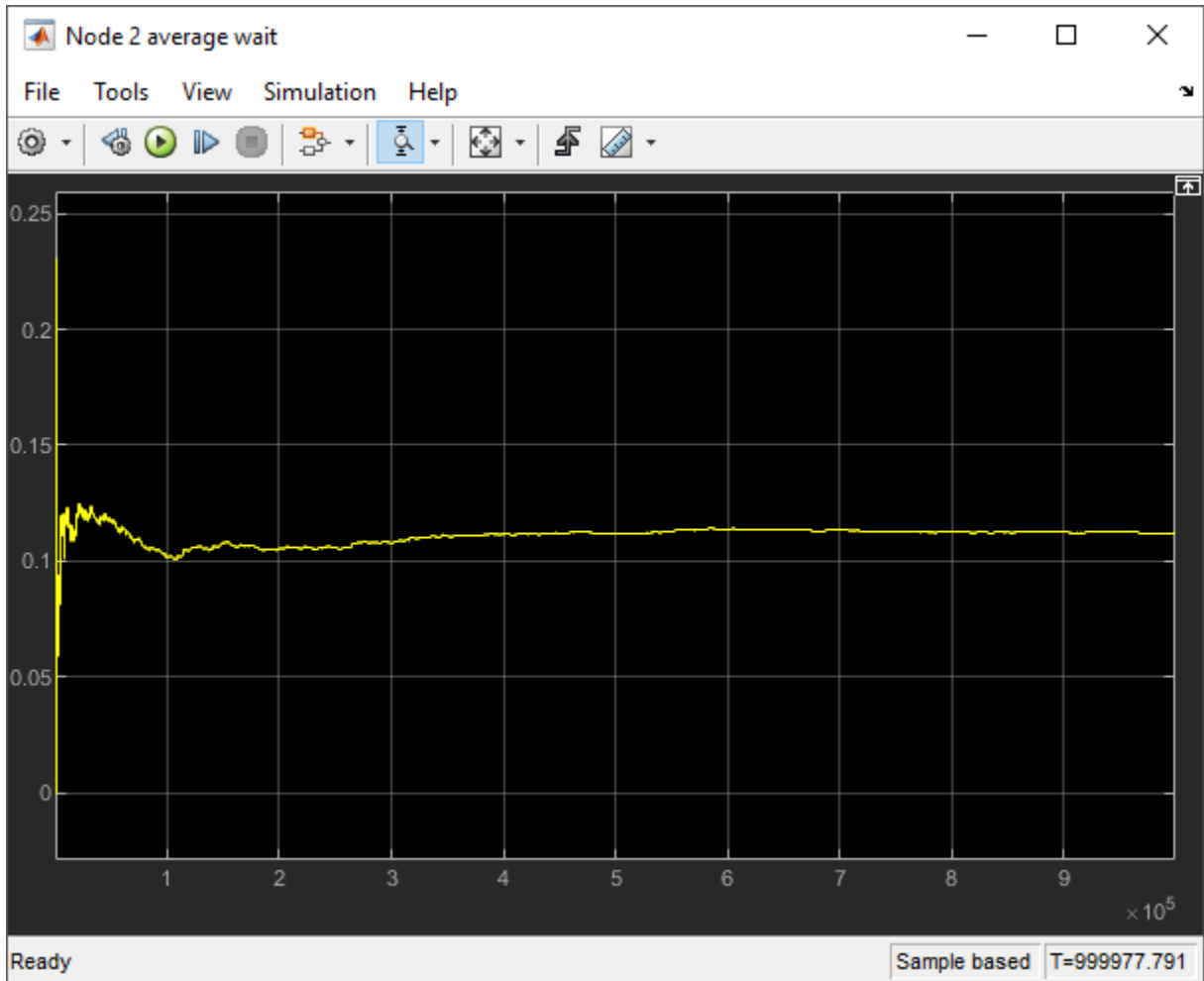

- The waiting time for the queue in node 3 converges to 0.88.

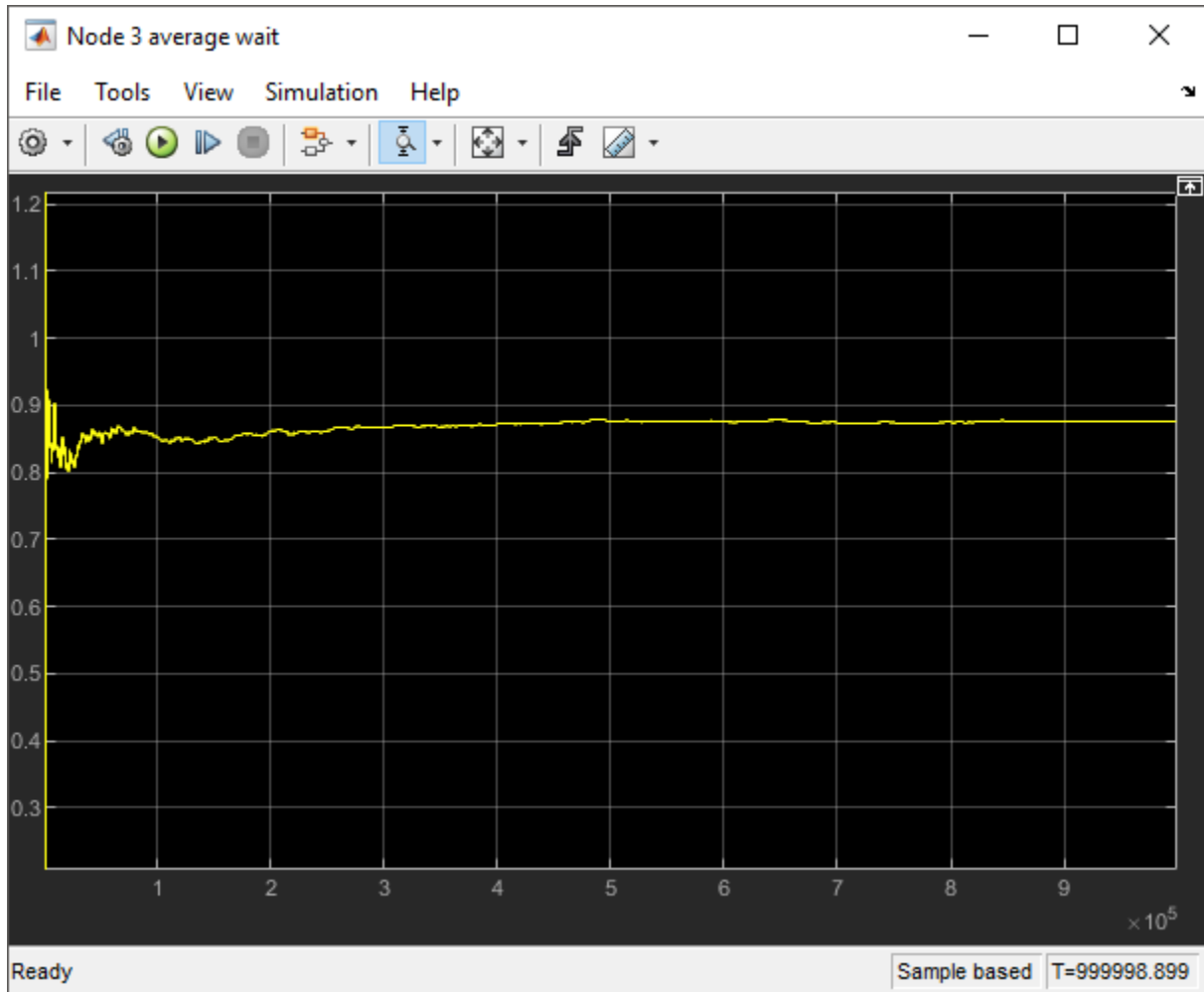

- The waiting time for the queue in node 4 converges to 0.58.

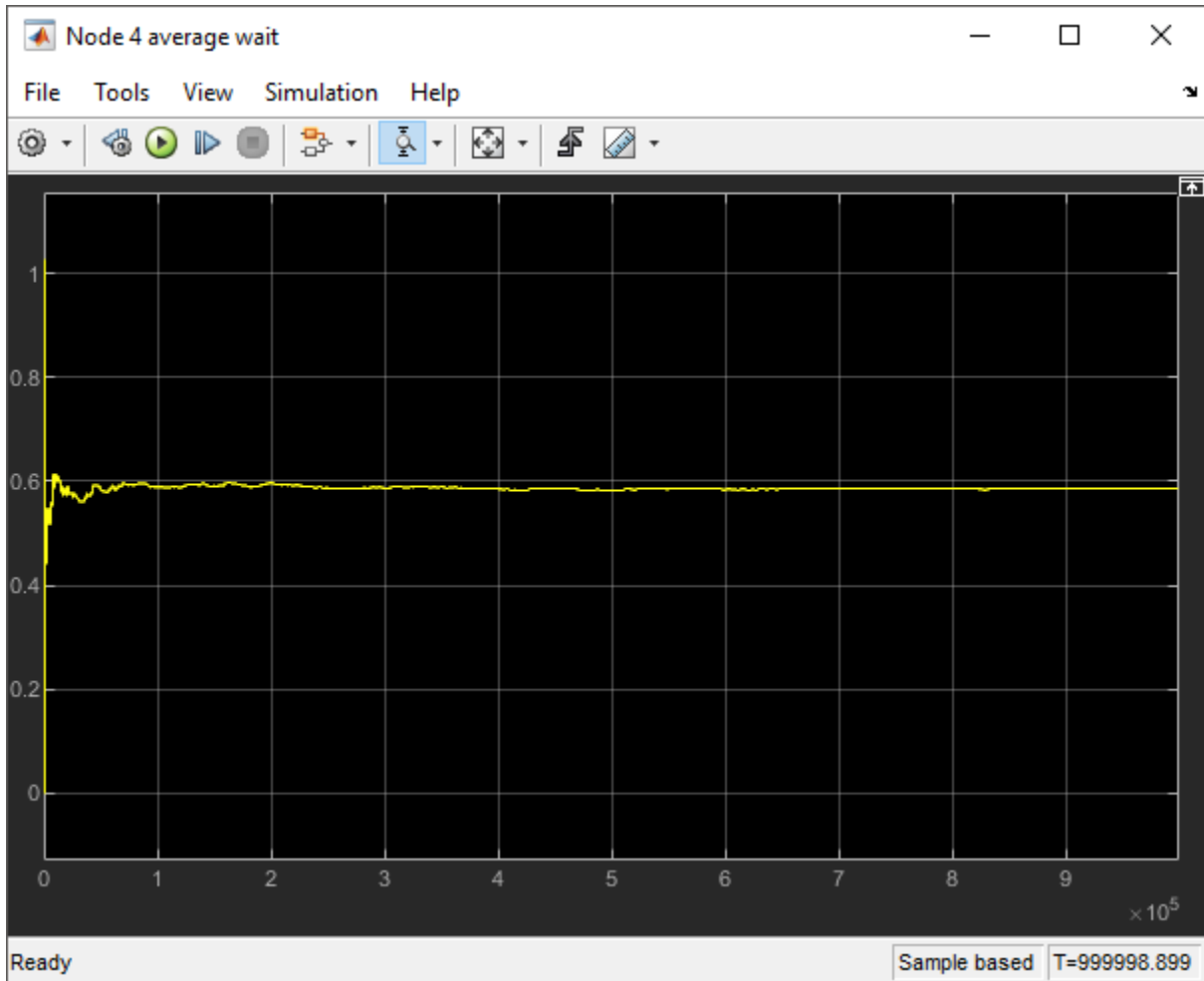

References

- [1] Jackson, James R. *Operations research* Vol. 5, No. 4 (Aug., 1957), pp 518-521.

Optimize SimEvents Models by Running Multiple Simulations

To optimize models in workflows that involve running multiple simulations, you can create simulation tests using the `Simulink.SimulationInput` object.

Grocery Store Model

The grocery store example uses multiple simulations approach to optimize the number of shopping carts required to prevent long customer waiting lines.

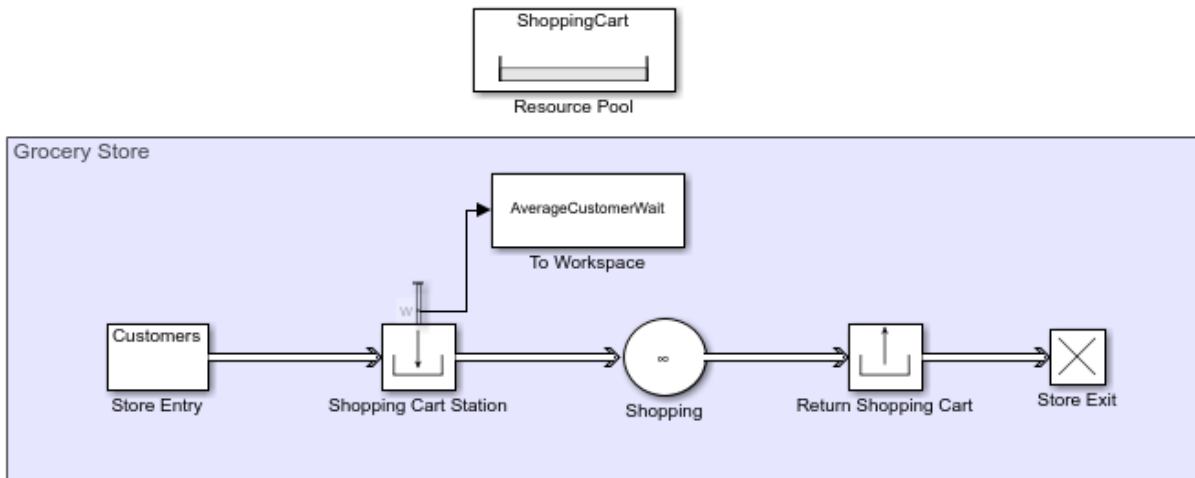

In this example, the Entity Generator block represents the customer entry to the store. The customers wait in line if necessary and get a shopping cart through the Resource Acquirer block. The Resource Pool block represents the available shopping carts in the store. The Entity Server block represents the time each customer spends in the store. The customers return the shopping carts through the Resource Releaser block, while the Entity Terminator block represents customer departure from the store. The Average wait,

w statistic from the Resource Acquirer block is saved to the workspace by the To Workspace block from the Simulink® library.

Build the Model

Grocery store customers wait in line if there are not enough shopping carts. However, having too many unused shopping carts is considered a waste. The goal of the example is to investigate the average customer wait time for a varying number of available shopping carts in the store. To compute the average customer wait time, multiple simulations are run by using the `sim` command. For each simulation, a single available shopping cart value is used. For more information on the `sim` command, see “Run Multiple Simulations” (Simulink) and “Run Parallel Simulations” (Simulink).

In the simulations, the available shopping cart value ranges from 20 to 50 and in each simulation it increases by 1. It is assumed that during the operational hours, customers arrive at the store with a random rate drawn from an exponential distribution and their shopping duration is drawn from a uniform distribution.

- 1 In the Entity Generator block, set the **Entity type name** to Customers and the **Time source** to MATLAB action. Then, enter this code.

```
persistent rngInit;
if isempty(rngInit)
    seed = 12345;
    rng(seed);
    rngInit = true;
end

% Pattern: Exponential distribution
mu = 1;
dt = -mu*log(1-rand());
```

The time between the customer arrivals is drawn from an exponential distribution with mean 1 minute.

- 2 In the Resource Pool block, specify the **Resource name** as ShoppingCart. Set the **Resource amount** to 20.

Initial value of available shopping carts is 20.

- 3 In the Resource Acquirer block, set the ShoppingCart as the **Selected Resources**, and set the **Maximum number of waiting entities** to Inf.

The example assumes a limitless number of customers who can wait for a shopping cart.

- 4 In the Entity Server block, set the **Capacity** to Inf.

The example assumes a limitless number of customers who can shop in the store.

- 5 In the Entity Server block, set the **Service time source** to MATLAB action and enter the code below.

```
persistent rngInit;
if isempty(rngInit)
    seed = 123456;
    rng(seed);
    rngInit = true;
end

% Pattern: Uniform distribution
% m: Minimum, M: Maximum
m = 20;
M = 40;
dt = m+(M-m)*rand;
```

The time a customer spends in the store is drawn from a uniform distribution on the interval between 20 minutes and 40 minutes.

- 6 Connect the **Average wait, w** statistic from the Resource Acquirer block to a To Workspace block and set its **Variable name** to AverageCustomerWait.
- 7 Set the simulation time to 600.

The duration of one simulation is 10 hours of operation which is 600 minutes.

- 8 Save the model.

For this example, the model is saved with the name GroceryStore_ShoppingCartExample.

Run Multiple Simulations to Optimize Resources

- 1 Open a new MATLAB script and run this MATLAB code for multiple simulations.
 - a Initialize the model and the available number of shopping carts for each simulation, which determines the number of simulations.

```
% Initialize the Grocery Store model with
% random intergeneration time and service time value
```

```
mdl = 'GroceryStore_ShoppingCartExample';
isModelOpen = bdIsLoaded(mdl);
open_system(mdl);

% Range of number of shopping carts that is
% used in each simulation
ShoppingCartNumber_Sweep = (20:1:50);
NumSims = length(ShoppingCartNumber_Sweep);
```

In each simulation, number of available shopping carts is increased by 1.

- b** Run each simulation with the corresponding available shopping cart value and output the results.

```
% Run NumSims number of simulations
NumCustomer = zeros(1,NumSims);
for i = 1:1:NumSims
    in(i) = Simulink.SimulationInput(mdl);
    % Use one ShoppingCartNumber_sweep value for each iteration
    in(i) = setBlockParameter(in(i), [mdl '/Resource Pool'], ...
        'ResourceAmount', num2str(ShoppingCartNumber_Sweep(i)));
end

% Output the results for each simulation
out = sim(in);
```

- c** Gather and visualize the results.

```
% Compute maximum average wait time for the
% customers for each simulation
MaximumWait = zeros(1,NumSims);
for i=1:NumSims
    MaximumWait(i) = max(out(1, i).AverageCustomerWait.Data);
end
% Visualize the plot
plot(ShoppingCartNumber_Sweep, MaximumWait,'bo');
grid on
xlabel('Number of Available Shopping Carts')
ylabel('Maximum Wait Time')
```

- 2** Observe the plot that displays the maximum average wait time for the customers as a function of available shopping carts.

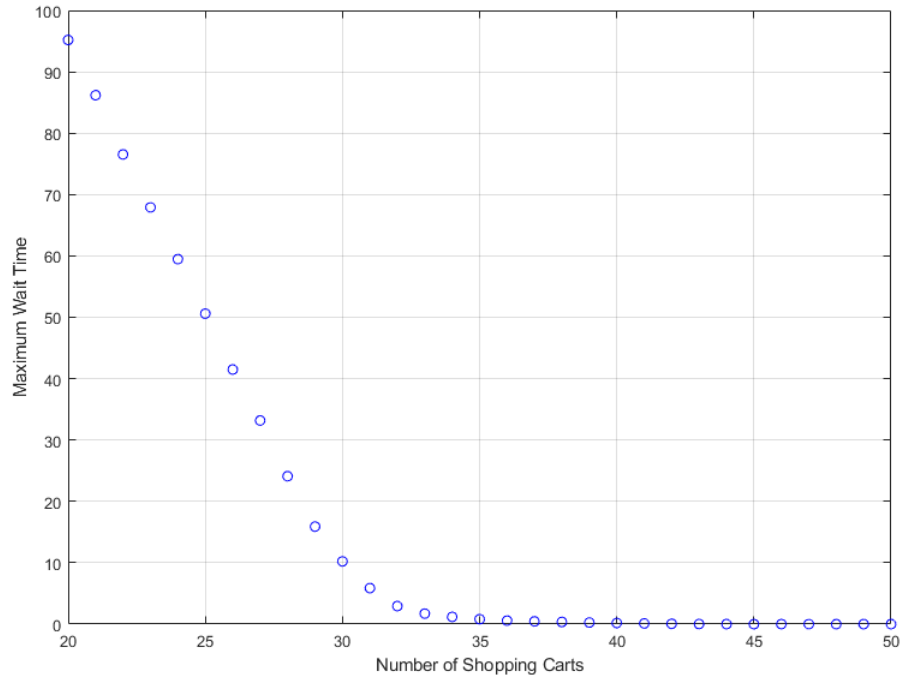

The plot displays the tradeoff between having 46 shopping carts available for zero wait time versus 33 shopping carts for a 2-minute customer wait time.

See Also

Entity Generator | Entity Queue | Entity Server | Entity Terminator | Resource Acquirer | Resource Pool | Resource Releaser

Related Examples

- “Optimization of Shared Resources in a Batch Production Process”
- “Explore Statistics and Visualize Simulation Results”

More About

- “Interpret SimEvents Models Using Statistical Analysis” on page 5-2
- “Count Entities”
- “Visualization and Animation for Debugging” on page 5-14
- “Adjust Entity Generation Times Through Feedback” on page 1-26
- “Save SimEvents Simulation Operating Point” on page 6-6

Use the Sequence Viewer Block to Visualize Messages, Events, and Entities

To see the interchange of messages and events between Stateflow charts in Simulink models and the movement of entities between SimEvents blocks, add a Sequence Viewer block to your Simulink model.

In the Sequence Viewer block, you can view event data related to Stateflow chart execution and the exchange of messages between Stateflow charts. The Sequence Viewer window shows messages as they are created, sent, forwarded, received, and destroyed at different times during model execution. The Sequence Viewer window also displays state activity, transitions, and function calls to Stateflow graphical functions, Simulink functions, and MATLAB functions.

With the Sequence Viewer block, you can visualize the movement of entities between blocks when simulating SimEvents models. All SimEvents blocks that can store entities appear as lifelines in the Sequence Viewer window. Entities moving between these blocks appear as lines with arrows. You can view calls to Simulink Function blocks and to MATLABFunction blocks.

You can add a Sequence Viewer block to the top level of a model or any subsystem. If you place a Sequence Viewer block in a subsystem that does not have messages, events, or state activity, the Sequence Viewer window informs you that there is nothing to display.

For instance, suppose that you simulate the Stateflow example `sf_msg_traffic_light`.

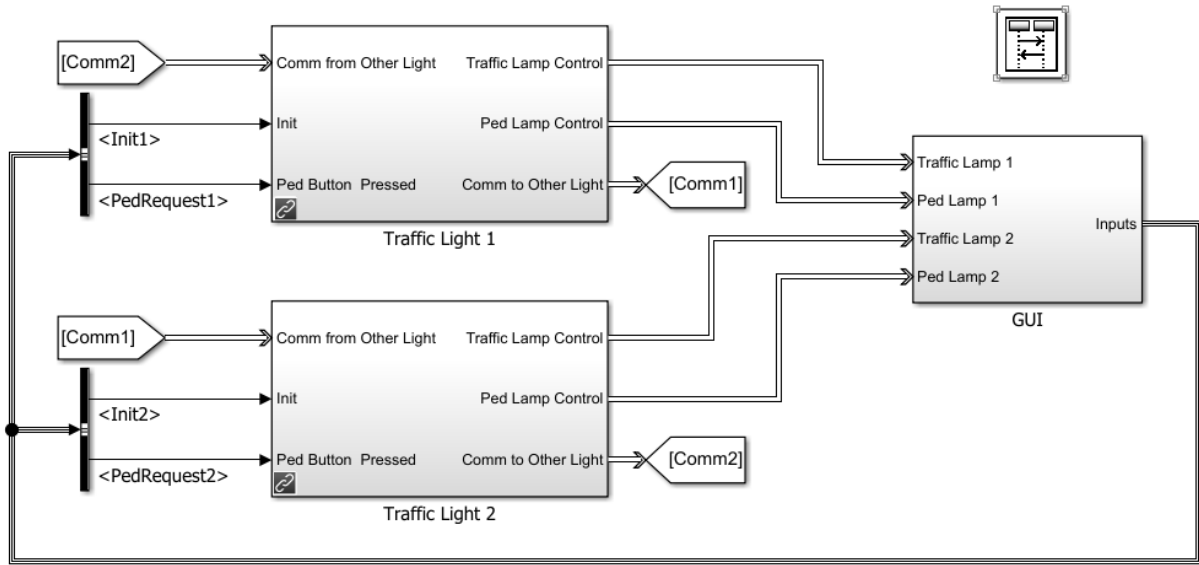

Copyright 2015, The MathWorks, Inc.



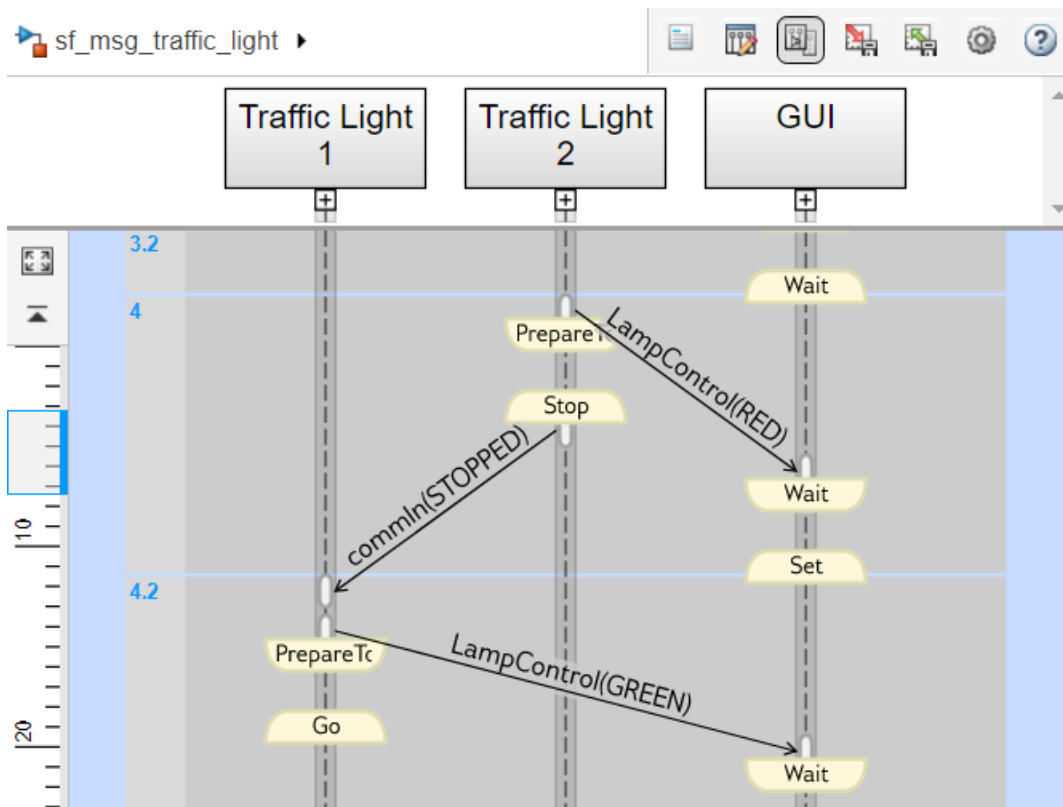

This model has three Simulink subsystems: Traffic Light 1, Traffic Light 2, and GUI. The Stateflow charts in these subsystems exchange data by sending messages. As messages pass through the system, you can view them in the Sequence Viewer window. The Sequence Viewer window represents each block in the model as a vertical lifeline with simulation time progressing downward.





Components of the Sequence Viewer Window

Navigation Toolbar

At the top of the Sequence Viewer window, a navigation toolbar displays the model hierarchy path. Using the toolbar buttons, you can:

-  Show or hide the Property Inspector.
-  Select an automatic or manual layout.
-  Show or hide inactive lifelines.
-  Save Sequence Viewer block settings.

-  Restore Sequence Viewer block settings.
-  Configure Sequence Viewer block parameters.
-  Access the Sequence Viewer block documentation.

Property Inspector

In the Property Inspector, you can choose filters to show or hide:

- Events
- Messages
- Function Calls
- State Changes and Transitions

Header Pane

The header pane below the Sequence Viewer toolbar shows lifeline headers containing the names of the corresponding blocks in a model.

- Gray rectangular headers correspond to subsystems.
- White rectangular headers correspond to masked subsystems.
- Yellow headers with rounded corners correspond to Stateflow charts.

To open a block in the model, click the name in the corresponding lifeline header. To show or hide a lifeline, double-click the corresponding header. To resize a lifeline header, click and drag its right-hand side. To fit all lifeline headers in the Sequence Viewer window, press the space bar.

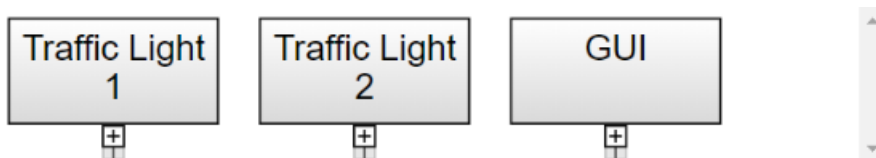

Message Pane

Below the header pane is the message pane. The message pane displays messages, events, and function calls between lifelines as arrows from the sender to the receiver. To display sender, receiver, and payload information in the Property Inspector, click the arrow corresponding to the message, event, or function call.

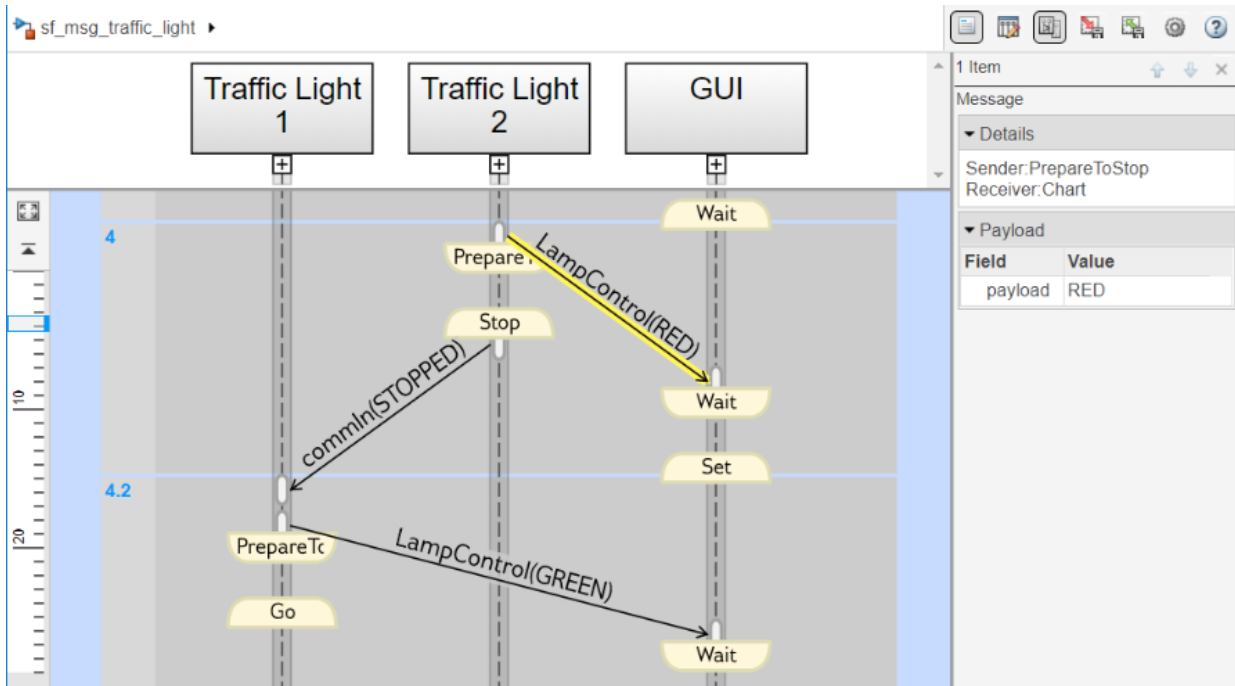

Navigate the Lifeline Hierarchy

In the Sequence Viewer window, the hierarchy of lifelines corresponds to the model hierarchy. When you pause or stop the model, you can expand or contract lifelines and change the root of focus for the viewer.

Expand a Parent Lifeline

In the message pane, a thick, gray lifeline indicates that you can expand the lifeline to see its children. To show the children of a lifeline, click the expander icon  below the header or double-click the parent lifeline.

For example, expanding the lifeline for the Traffic Light 1 block reveals two new lifelines corresponding to the Stateflow charts Ped Button Sensor and Controller.

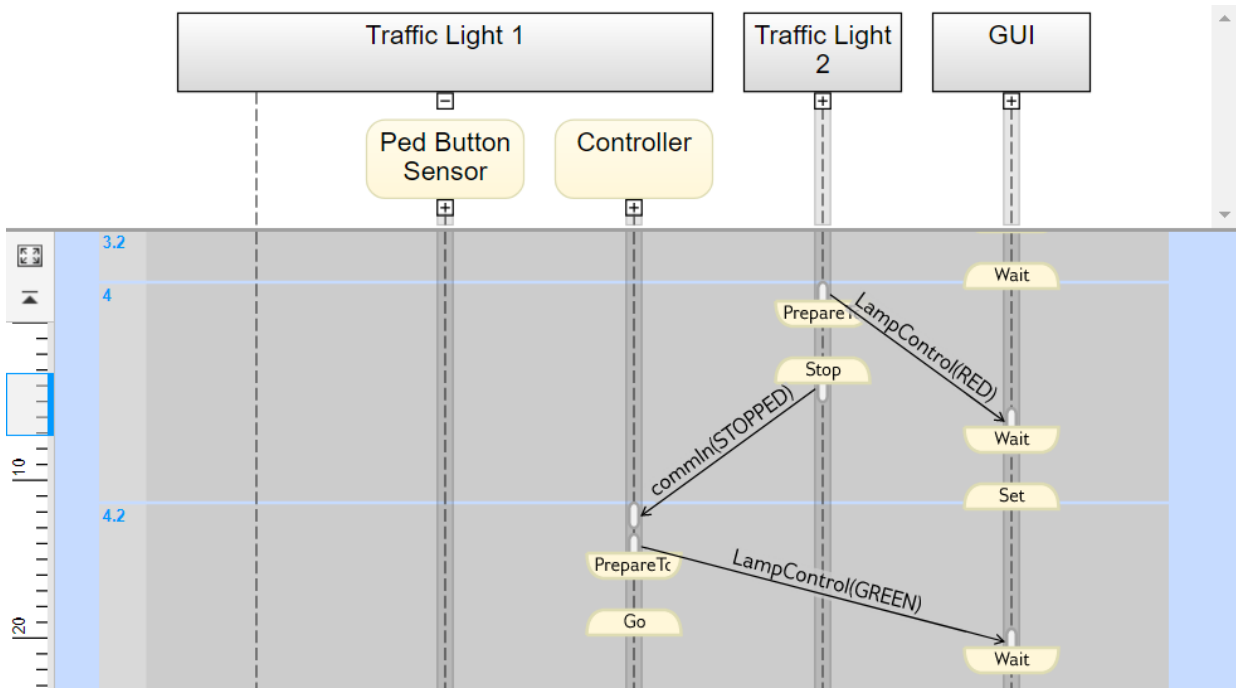

Expand a Masked Subsystem Lifeline

The Sequence Viewer window displays masked subsystems as white blocks. To show the children of a masked subsystem, point over the bottom left corner of the lifeline header and click the arrow.

For example, the GUI subsystem contains four masked subsystems: Traffic Lamp 1, Traffic Lamp 2, Ped Lamp 1, and Ped Lamp 2.



You can display the child lifelines in these masked subsystems by clicking the arrow in the parent lifeline header.

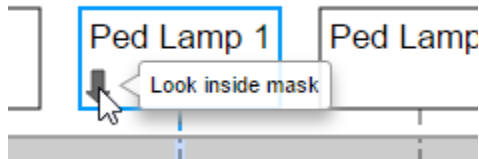

Change Root of Focus

To make a lifeline the root of focus for the viewer, point over the bottom left corner of the lifeline header and click the arrow. Alternatively, you can use the navigation toolbar at the top of the Sequence Viewer window to move the current root up and down the lifeline hierarchy. To move the current root up one level, press the **Esc** key.

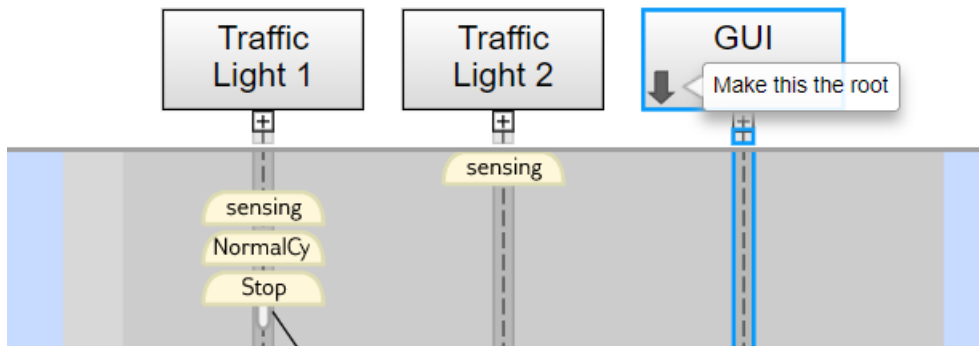

The Sequence Viewer window displays the current root lifeline path and shows its child lifelines. Any external events and messages are displayed as entering or exiting through vertical slots in the diagram gutter. When you point to a slot in the diagram gutter, a tooltip displays the name of the sending or receiving block.

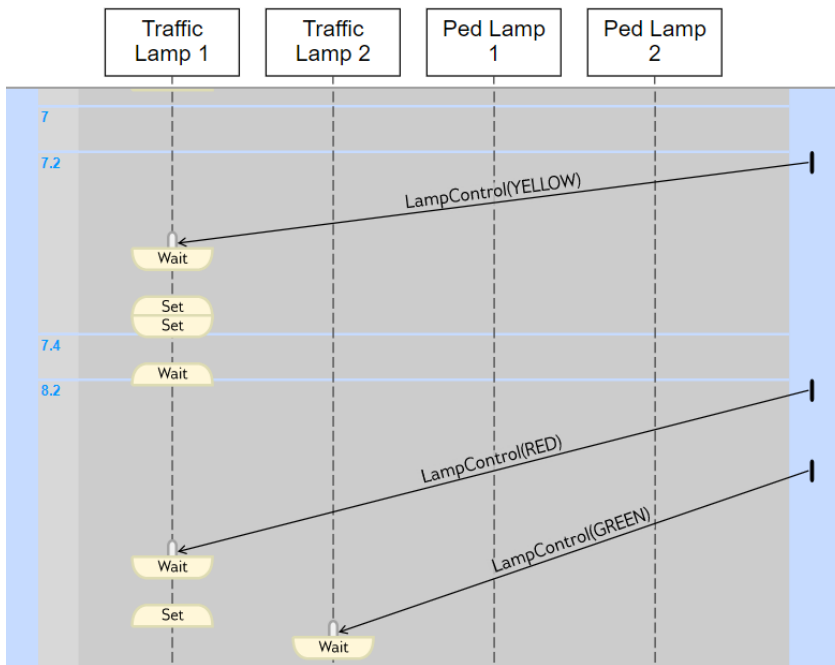

View State Activity and Transitions

To see state activity and transitions in the Sequence Viewer window, expand the state hierarchy until you have reached the lowest child state. Vertical yellow bars show which state is active. Blue horizontal arrows denote the transitions between states.

In this example, you can see a transition from Go to PrepareToStop followed, after 1 second, by a transition to Stop.

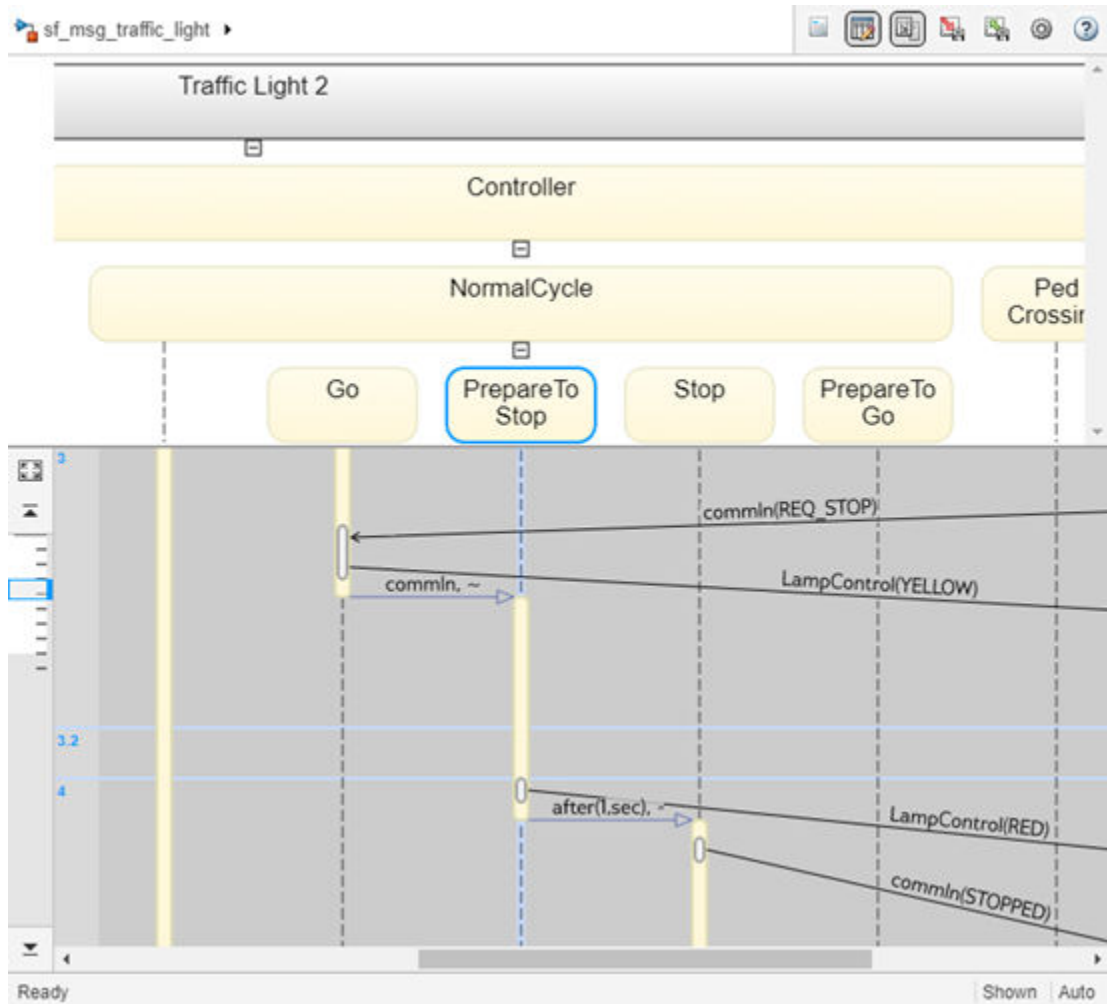

To display the start state, end state, and full transition label in the Property Inspector, click the arrow corresponding to the transition.

To display information about the interactions that occur while a state is active, click the yellow bar corresponding to the state. In the Property Inspector, use the **Search Up** and **Search Down** buttons to move through the transitions, messages, events, and function calls that take place while the state is active.

View Function Calls

The Sequence Viewer block displays function calls and replies. This table lists the type of support for each type of function call.

Function Call Type	Support
Calls to Simulink Function blocks	Fully supported
Calls to Stateflow graphical or Stateflow MATLAB functions	<ul style="list-style-type: none"> Scoped — Select the Export chart level functions chart option. Use the <i>chartName.functionName</i> dot notation. Global — Select the Treat exported functions as globally visible chart option. You do not need the dot notation.
Calls to function-call subsystems	Not displayed in the Sequence Viewer window

The Sequence Viewer window displays function calls as solid arrows labeled with the format *function_name(argument_list)*. Replies to function calls are displayed as dashed arrows labeled with the format *[argument_list]=function_name*.

For example, in the model `slexPrinterExample`, a subsystem calls the Simulink Function block `addPrinterJob`. The function block replies with an output value of `false`.

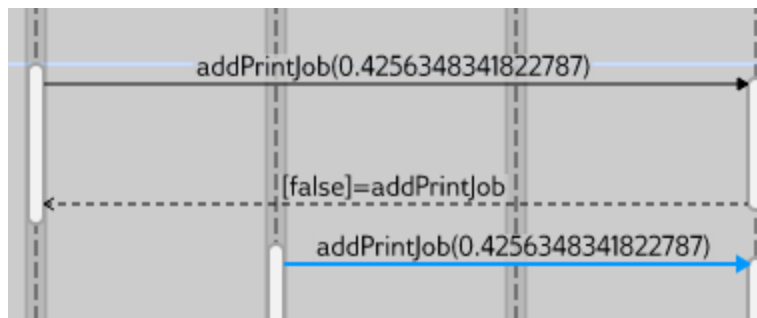

Simulation Time in the Sequence Viewer Window

The Sequence Viewer window shows events vertically, ordered in time. Multiple events in Simulink can happen at the same time. Conversely, there can be long periods of time during simulation with no events. As a consequence, the Sequence Viewer window shows

time by using a combination of linear and nonlinear displays. The time ruler shows linear simulation time. The time grid shows time in a nonlinear fashion. Each time grid row, bordered by two blue lines, contains events that occur at the same simulation time. The time strip provides the times of the events in that grid row.

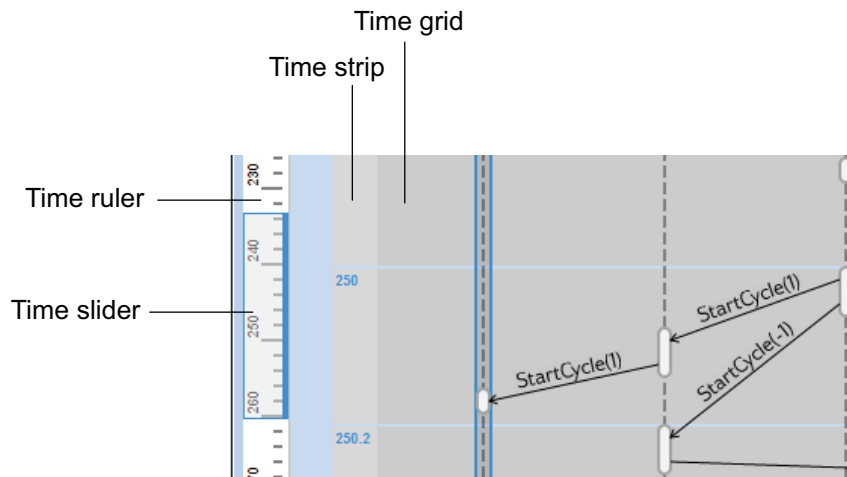



To show events in a specific simulation time range, use the scroll wheel or drag the time slider up and down the time ruler. To navigate to the beginning or end of the simulation, click the **Go to first event** or **Go to last event** buttons. To see the entire simulation duration on the time ruler, click the **Fit to view** button .

When using a variable step solver, you can adjust the precision of the time ruler. In the Model Explorer, on the **Main** tab of the Sequence Viewer Block Parameters pane, adjust the value of the **Time Precision for Variable Step** field.

Redisplay of Information in the Sequence Viewer Window

The Sequence Viewer block saves the order and states of lifelines between simulation runs. When you close and reopen the Sequence Viewer window, it preserves the last open

lifeline state. To save a particular viewer state, click the **Save Settings** button  in the toolbar. Saving the model then saves that state information across sessions. To load the saved settings, click the **Restore Settings** button .

You can modify the **Time Precision for Variable Step** and **History** parameters only between simulations. You can access the buttons in the toolbar before simulation or when the simulation is paused. During a simulation, the buttons in the toolbar are disabled.

See Also

Sequence Viewer

More About

- “Synchronize Model Components by Broadcasting Events” (Stateflow)
- “Communicate with Stateflow Charts by Sending Messages” (Stateflow)

Learning More About SimEvents Software

- “Event Calendar” on page 6-2
- “Entity Priorities” on page 6-3
- “Livelock Prevention” on page 6-5
- “Save SimEvents Simulation Operating Point” on page 6-6
- “Example Model to Count Simultaneous Departures from a Server” on page 6-12
- “Example Model for Noncumulative Entity Count” on page 6-13
- “Example Model for Discouraged Arrival” on page 6-14
- “A Simple Example of Generating Multiple Entities” on page 6-15
- “A Simple Example of Event-Based Entity Generation” on page 6-16
- “Serve Preferred Customers First” on page 6-17
- “Find and Examine Entities” on page 6-18
- “Extract Found Entities” on page 6-21
- “Trigger Entity Find Block with Event Actions” on page 6-22
- “Build a Firewall and an Email Server” on page 6-23
- “Implement the Custom Entity Storage Block” on page 6-24
- “Implement the Custom Entity Storage Block with Iteration Event” on page 6-25
- “Implement the Custom Entity Storage Block with Two Timer Events” on page 6-26
- “Implement the Custom Entity Generator Block” on page 6-27
- “Implement the Custom Entity Storage Block with Two Storages” on page 6-28

Event Calendar

During a simulation, the model maintains a list, called the event calendar, of upcoming events that are scheduled for the current simulation time or future times. The event calendar sorts multiple events that are scheduled for the same time by the priority of the entity for which they are scheduled. The model refers to the event calendar to execute events at the correct simulation time and in an appropriately prioritized sequence.

These are the events that the event calendar tracks.

Event	For Blocks
Generate	Entity Generator, MATLAB Discrete-Event System
Forward	Entity Generator, Entity Queue, Multicast Receive Queue, Entity Server, Entity Terminator, Discrete Event Chart, MATLAB Discrete Event System, Entity Replicator, Resource Acquirer
ServiceComplete	Entity Server
Timer	MATLAB Discrete-Event System, Discrete Event Chart
Iterate	MATLAB Discrete-Event System
Destroy	MATLAB Discrete-Event System

See Also

Discrete Event Chart | Entity Generator | Entity Queue | Entity Server | MATLAB Discrete Event System | Resource Acquirer

More About

- “Debug SimEvents Models” on page 12-2
- “Visualization and Animation for Debugging” on page 5-14
- “Observe Entities Using simevents.SimulationObserver Class” on page 10-8
- “Use SimulationObserver Class to Monitor a SimEvents Model” on page 10-2

Entity Priorities

SimEvents software uses entity priorities to prioritize events. The smaller the priority value, the higher the priority.

You specify entity priorities when you generate entities. You can later change entity priorities using an event action for the priority. For example, in the Entity Generator **Event actions** tab, you can define an event action to change the entity priority during simulation using code such as:

```
entitySys.priority=MATLAB code
```

The event calendar includes event types such as:

- Entity generation
- Entity forwarding
- Entity destruction
- Timer
- Service completion

The event calendar sorts events based on times and associated entity priorities as outlined here:

- 1 The event that has the earliest time executes first.
- 2 If two entities have events occurring at the same time, the event with the entity of higher priority occurs first.
- 3 If both entities have the same priority, it is undefined which event is served first. To get deterministic order, change one of the entity priorities.

For example, assume a forward event associated with an entity that exits block *A* and enters block *B*. The priority of this event is the priority of the entity being forwarded. If there are two entities trying to depart a block at the same time, the entity with the higher priority departs first.

See Also

Discrete Event Chart | Entity Generator | Entity Queue | Entity Replicator | Entity Server | Entity Terminator | MATLAB Discrete Event System | Multicast Receive Queue | Resource Acquirer

Related Examples

- “Sort by Priority” on page 2-6

Livelock Prevention

Large Finite Numbers of Simultaneous Events

Simultaneous events are events that occur at the same simulation clock time. Events scheduled on the event calendar for times T and $T+\Delta t$ are considered simultaneous if $0 \leq \Delta t \leq 128*\text{eps}*T$, where eps is the floating-point relative accuracy in MATLAB software and T is the simulation time. If your simulation creates a large number of simultaneous events, this number might be an indication of an unwanted livelock situation. In this situation, a block returns to the same state infinitely often at the same time instant. SimEvents software prevents livelock with these limits:

- SimEvents software limits the maximum number of simultaneous events per block to 5,000.
- SimEvents software limits the maximum number of simultaneous events per model to 100,000.

See Also

More About

- “Solvers for Discrete-Event Systems” on page 7-6

Save SimEvents Simulation Operating Point

This example shows how to save and restore the simulation state of a SimEvents model by using **Save final operating point** check box and use it as an initial state for future simulations. For more information about using **Save final operating point**, see “Save and Restore Simulation Operating Point” (Simulink).

The **Save final operating point** check box is used to save the state of a simple queuing system with an Entity Generator block, an Entity Queue block, an Entity Server block, and an Entity Terminator block. The signal output port **n** displaying the number of entities departed the Entity Queue block is connected to a Scope block. For more information about performing basic tasks to create this model, see “Create a Discrete-Event Model”. The only difference in the model is the placement of the scope.

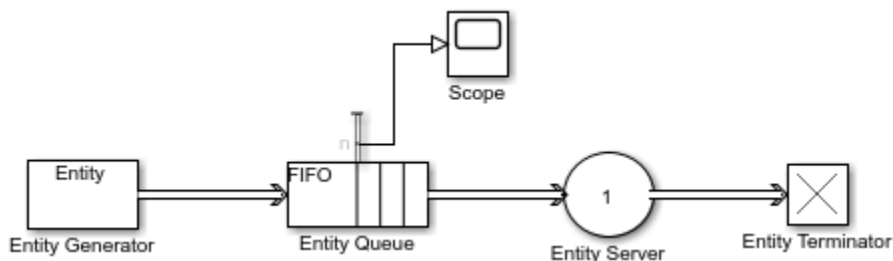

- 1 Open the Entity Server Block Parameters dialog box. Set the **Service time value** to 2.

The queue length increases throughout the simulation because service time is larger than the entity intergeneration time.

- 2 From the Simulink Toolstrip, select **Modeling** tab and **Model Settings**. In the Configuration Parameters dialog box, in the **Data Import/Export** pane, select the **Final states** check box with the variable name `xFinal` and select the **Save final operating point** check box.

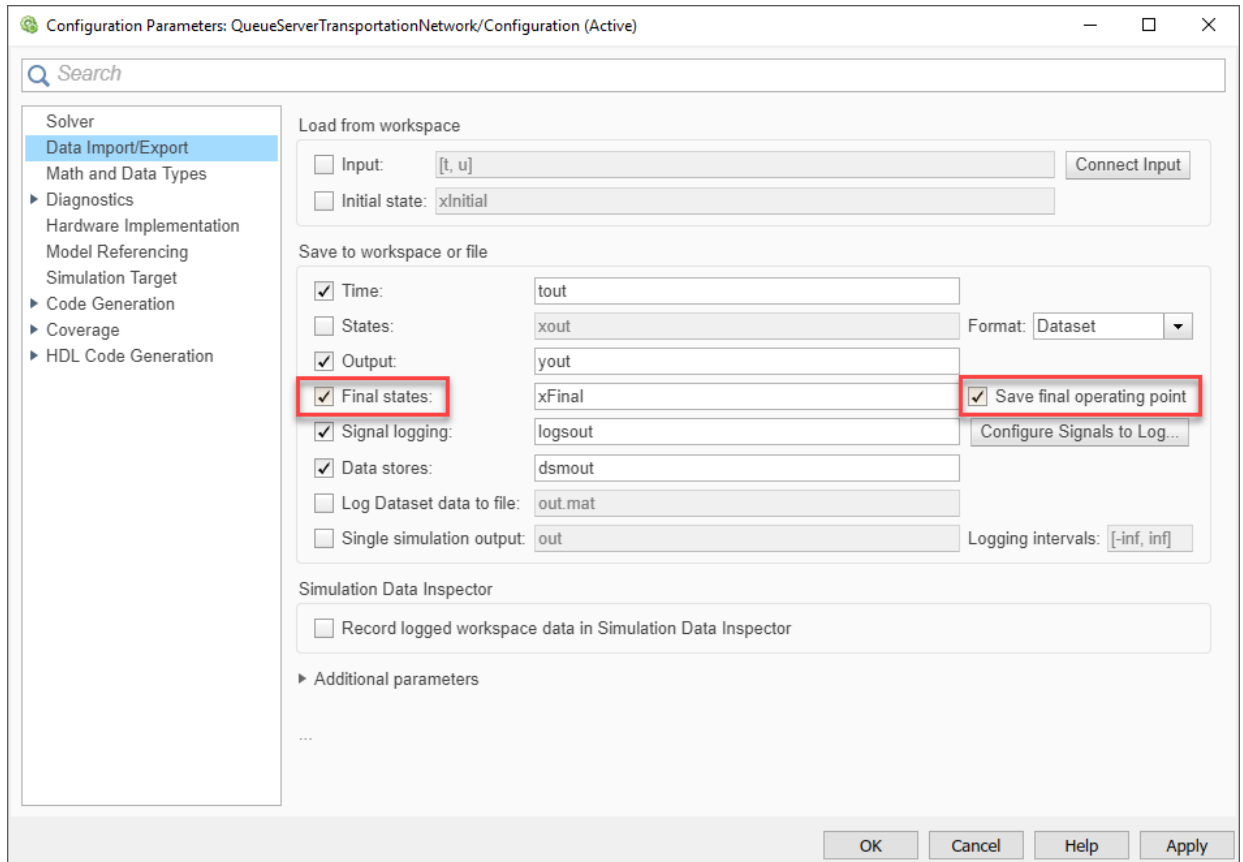

- 3 Simulate the model and open the Scope block. Observe that the final queue length is 6.

The queue length increases, with spikes at times 2, 4, 6, 8, and 10 because the **Service time value** of the Entity Server block is 2. The entity in the Entity Server block departs, and the entity that arrives at the Entity Queue block immediately advances to the Entity Server block.

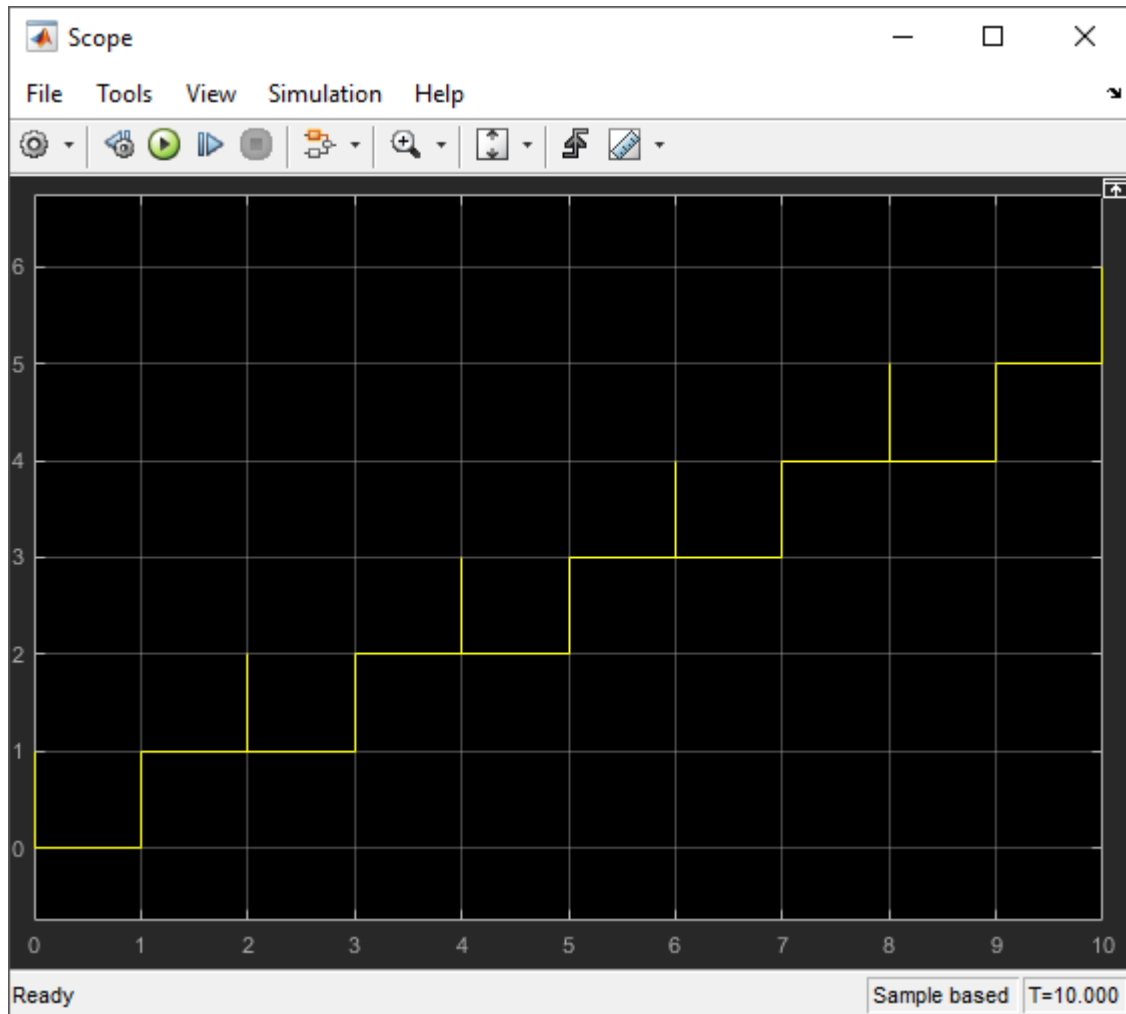

- 4 In the Configuration Parameters dialog box, select the **Initial state** check box and specify the variable name as `xFinal`.

`xFinal` is used as an initial state for the next simulation.

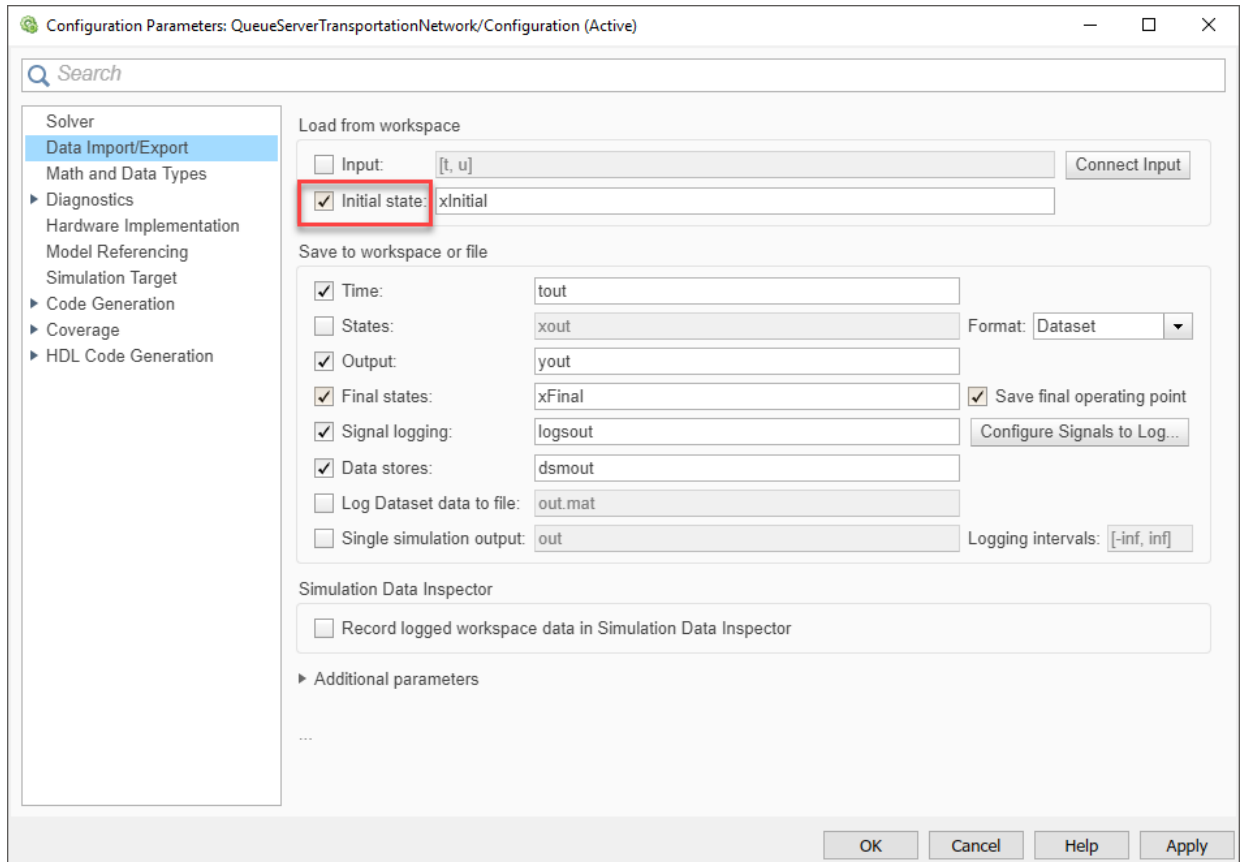

- 5 Increase the simulation time to 20.

Set the simulation time larger than 10 to observe simulation with the saved initial simulation state.

- 6 Simulate the model. Open the Scope block. Observe that the simulation starts from the queue length 6, which is the final state of the previous simulation.

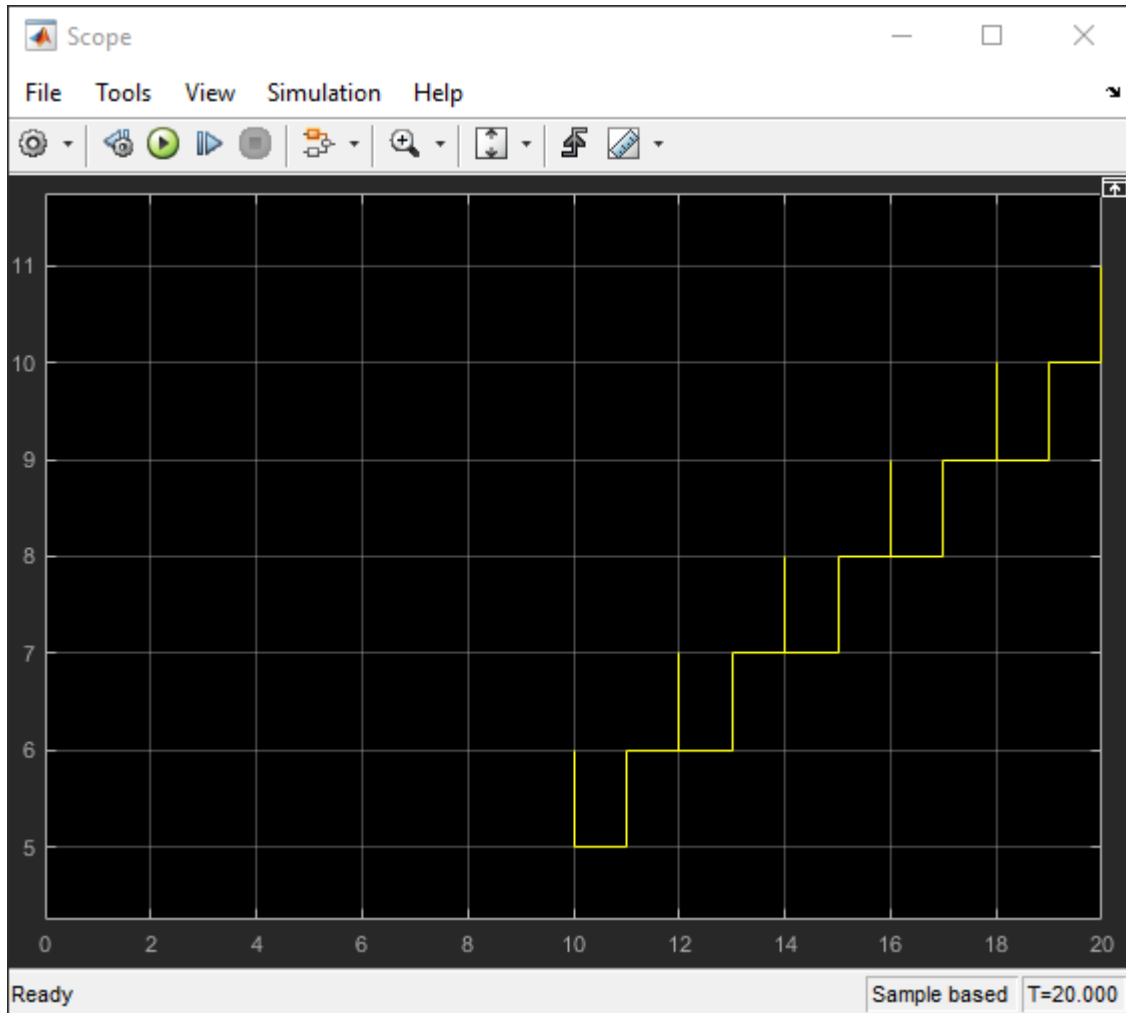

See Also

[Entity Generator](#) | [Entity Queue](#) | [Entity Server](#) | [Entity Terminator](#)

Related Examples

- “Solvers for Discrete-Event Systems” on page 7-6
- “Debug SimEvents Models” on page 12-2
- “Manage Entities Using Event Actions”

Example Model to Count Simultaneous Departures from a Server

This example shows how to count the simultaneous departures of entities from a server. Use the **Number of entities departed, d** statistic from the Entity Server block to learn how many entities have departed the block. The output signal also indicates when departures occurred. This method of counting is cumulative throughout the simulation.

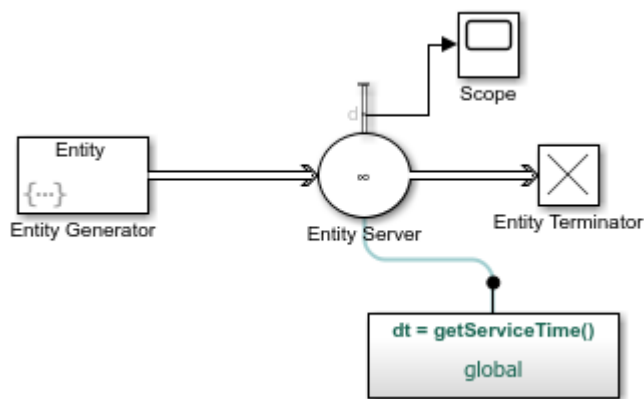

Example Model for Noncumulative Entity Count

This example shows how to count entities, which arrive to an Entity Terminator block, in a noncumulative way by resetting the counter at each time instant.

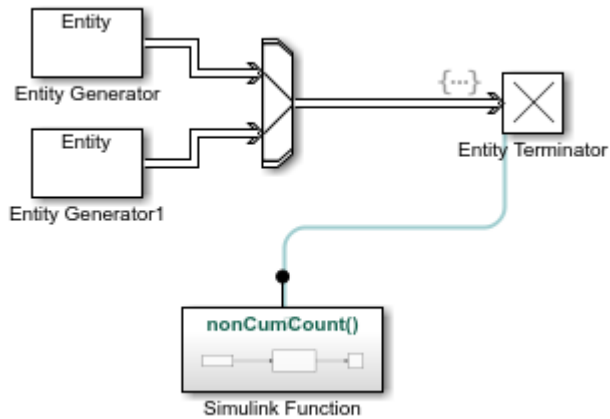

Example Model for Discouraged Arrival

This example shows a queuing system in which feedback influences the arrival rate. The goal of the feedback loop is to stabilize the entity queue by slowing the entity generation rate of the Entity Generator block as more entities accumulate in the Entity Queue block and the Entity Server block.

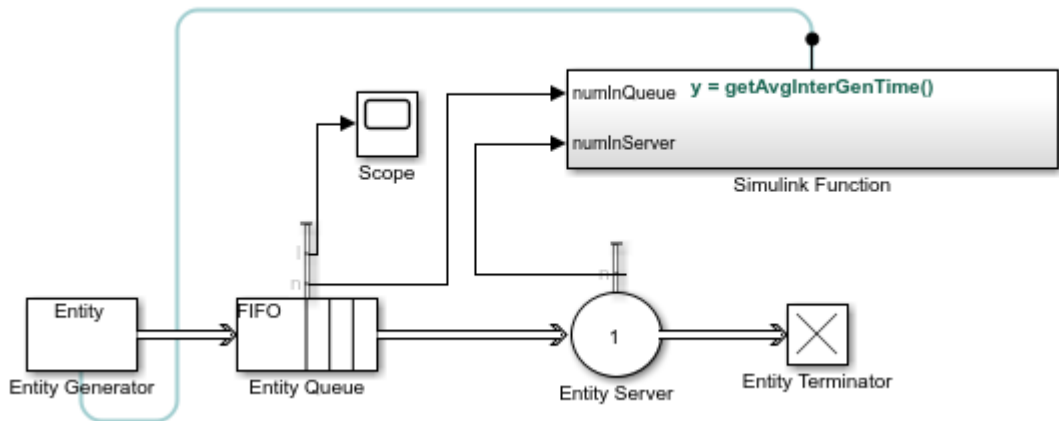

A Simple Example of Generating Multiple Entities

In this example, you can simultaneously generate multiple entities at the start of the simulation. You can then observe the behavior of the model from the output of the Dashboard Scope block.

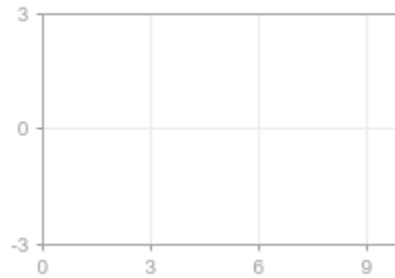

A Simple Example of Event-Based Entity Generation

In this example, you generate entities based on the message arrival to the Entity Generator block.

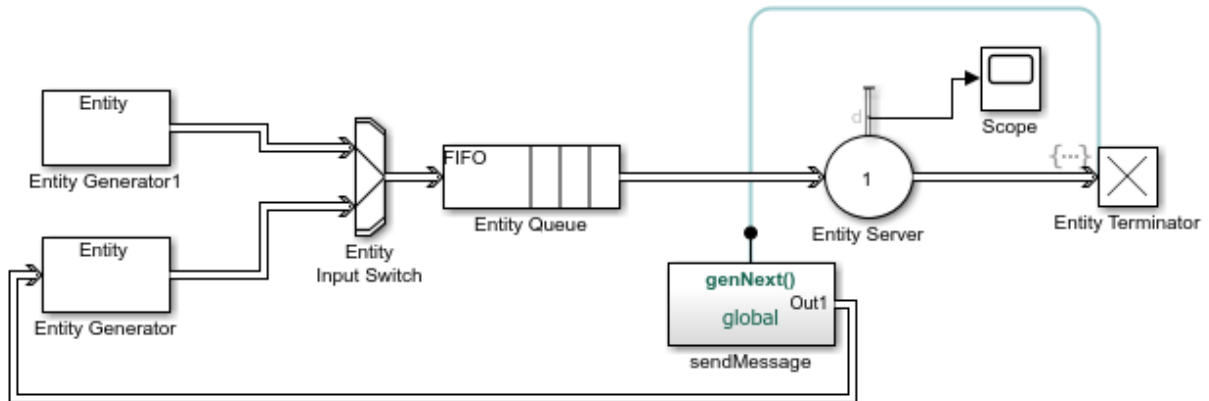

Serve Preferred Customers First

In this example, two types of customers enter a queuing system. One type, considered to be preferred customers, are less common but require longer service. The priority queue places preferred customers ahead of nonpreferred customers. The model plots the average system time for the set of preferred customers and separately for the set of nonpreferred customers in a Dashboard Scope block.

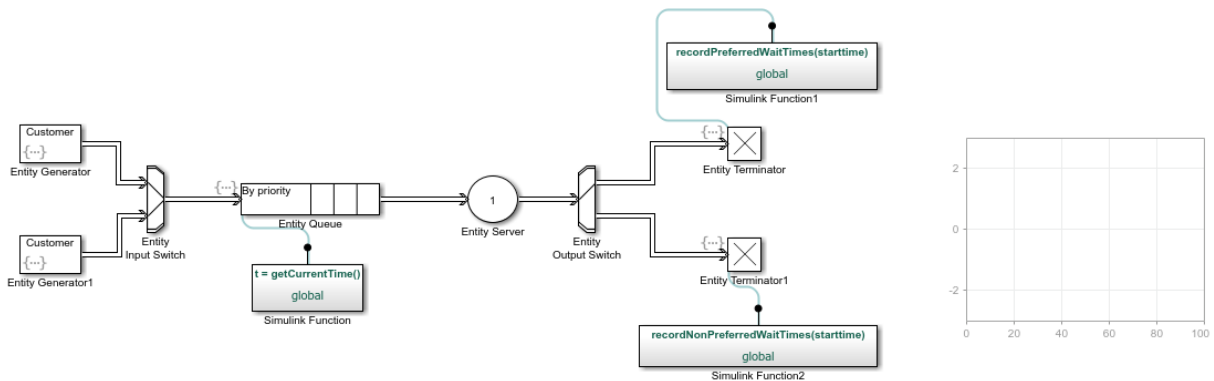

Find and Examine Entities

This example shows how to use the Entity Find block to find and examine entities at their location. In this example, the block finds entities that are tagged with a resource from the Resource Pool block.

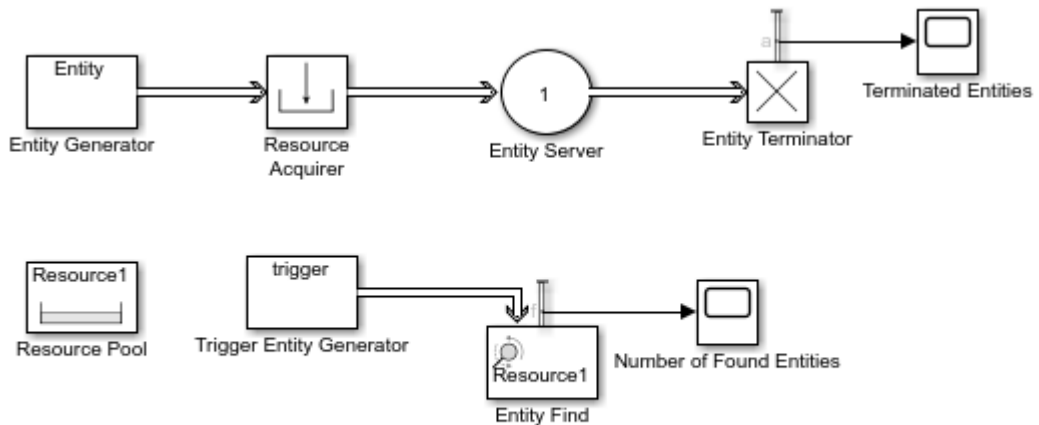

Copyright 2019 The MathWorks, Inc.

Model Description

- The top model represents the flow of entities that acquire a Resource1 resource.
- By default, the Entity Find block finds the entities having Resource1 tag.
- Every time the Trigger Entity Generator generates an entity, the Entity Find block is triggered to find entities.

Simulation Results

Simulate the model and observe the Scope blocks labeled as Terminated Entities and Number of Found Entities. The number of terminated entities is 10.

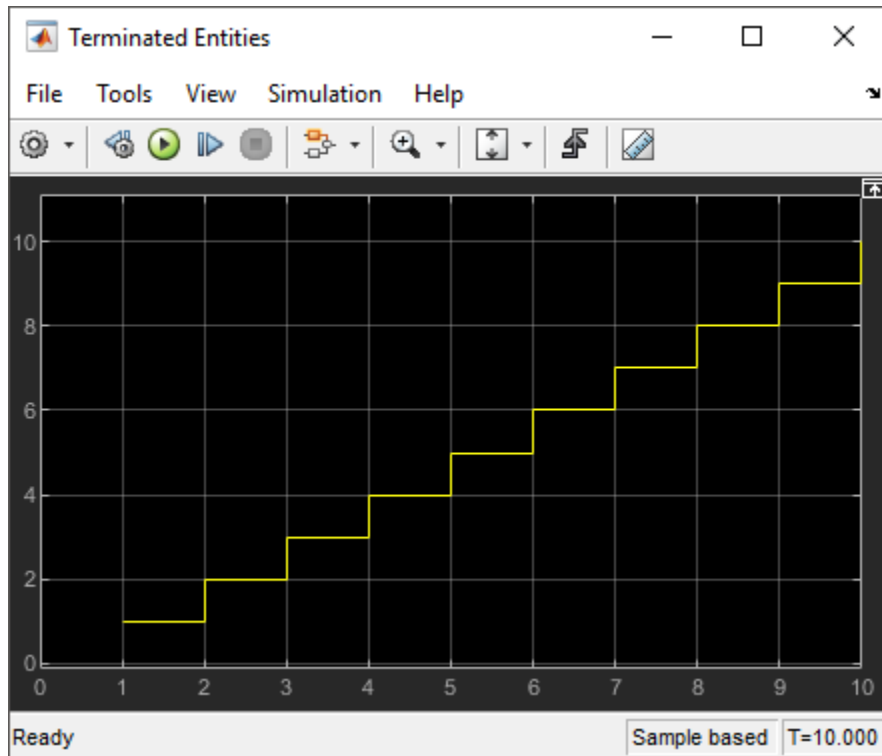

The number of found entities by the Entity Find block is also 10. This is because every generated entity acquires a Resource1 tag and no entities are blocked in the model.

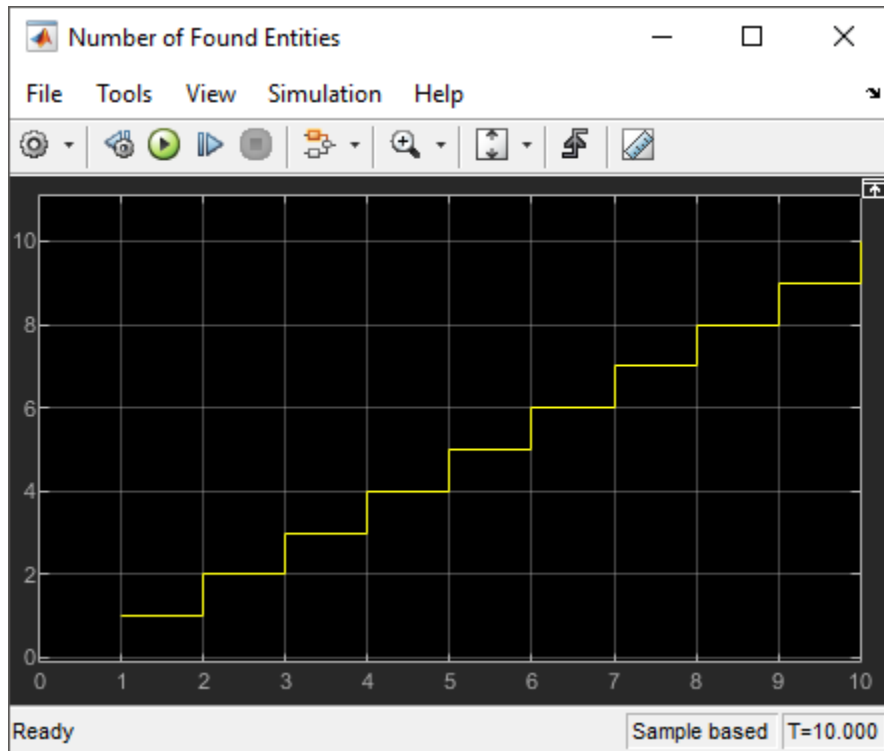

You can also modify and extract found entities. For more information, see “Find and Extract Entities in SimEvents Models” on page 4-10.

See Also

Entity Find | Resource Acquirer | Resource Pool

More About

- “Find and Extract Entities in SimEvents Models” on page 4-10

Extract Found Entities

You can use the Entity Find block to find entities and extract them from their location to reroute. In this example, 3 entities found in the previous example are extracted from the system to be terminated.

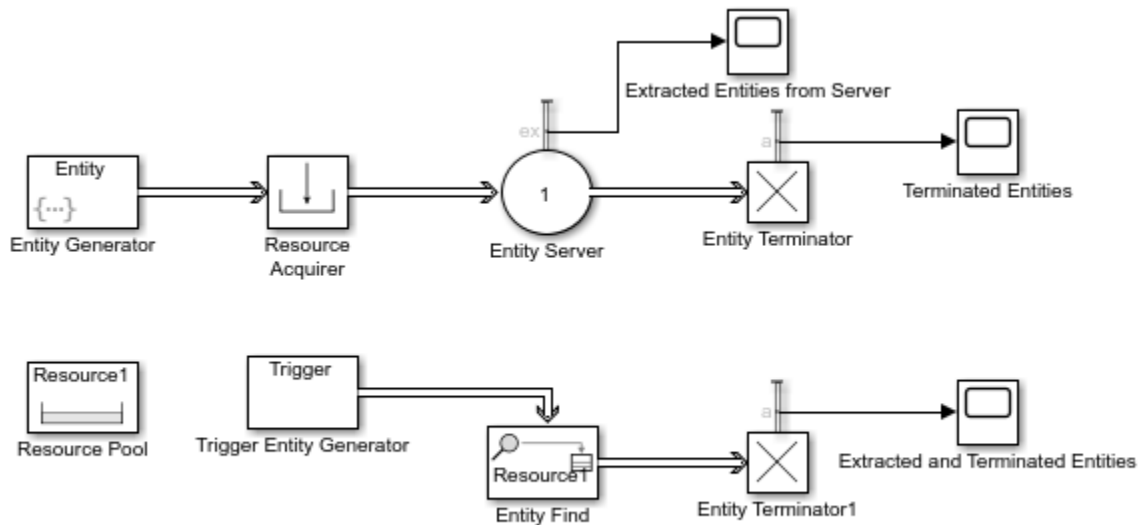

Copyright 2019 The MathWorks, Inc.

Trigger Entity Find Block with Event Actions

You can trigger the Entity Find block with event actions. In this example, the Entity Find block is triggered when an entity enters the Entity Server block. Modify the previous example by removing the Trigger Entity Generator and by adding the Entity Output Switch, Entity Server1, Entity Terminator2 and Scope blocks to the model and connect them as shown.

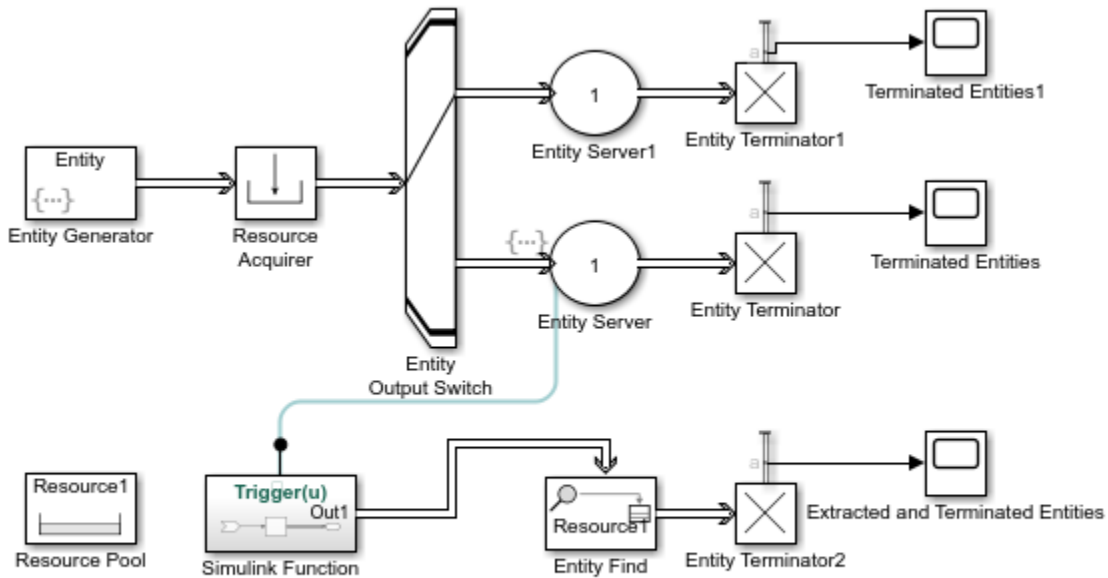

Copyright 2019 The MathWorks, Inc.

Build a Firewall and an Email Server

You can use the Entity Find block to monitor multiple blocks in a model, to examine, and to extract entities.

This example represents an email server with a firewall to track, monitor, and discard harmful emails before they reach the user. In the model, emails are generated using an Entity Generator block. In the Firewall component, all emails are classified as harmful for instant discarding, suspicious for monitoring, or safe based on their source. Harmful emails are tagged with a `DiscardTag` resource from the Resource Pool block and instantly discarded from the system. Suspicious emails are tagged with `MonitorTag` and tracked throughout the system for suspicious activity. If a suspicious activity is detected, the email is discarded before it reaches the user. Safe emails are not monitored or discarded.

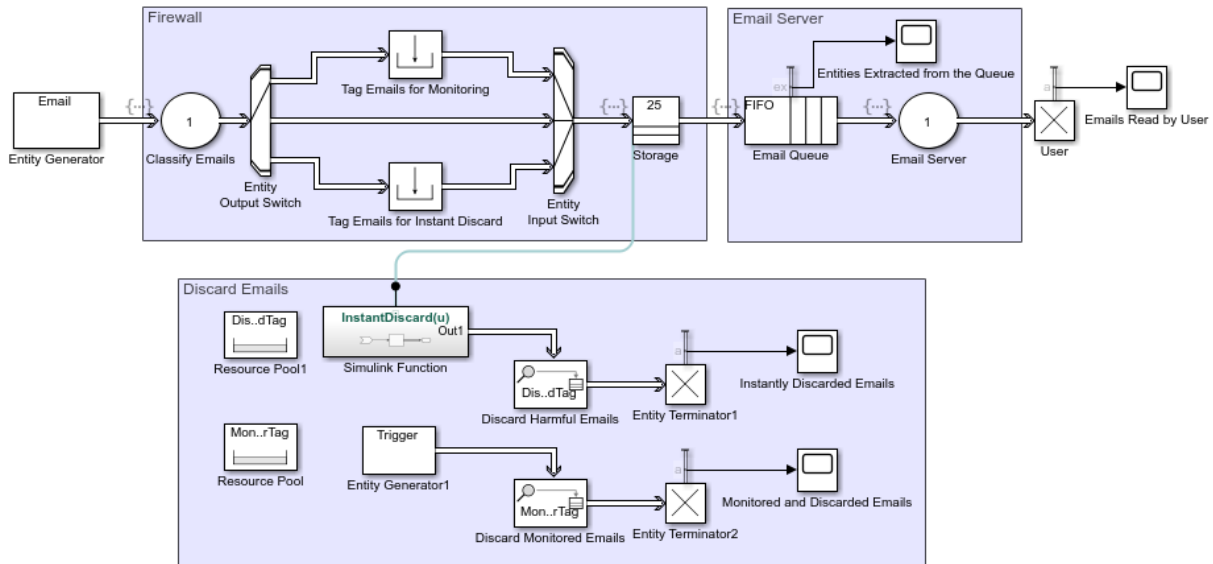

Copyright 2019 The MathWorks, Inc.

Implement the Custom Entity Storage Block

This example shows how to implement a discrete-event System Object™ using a MATLAB Discrete-Event system block. The model also includes an Entity Generator block and an Entity Terminator block. The custom block accepts entities and forwards them with a delay of 4.

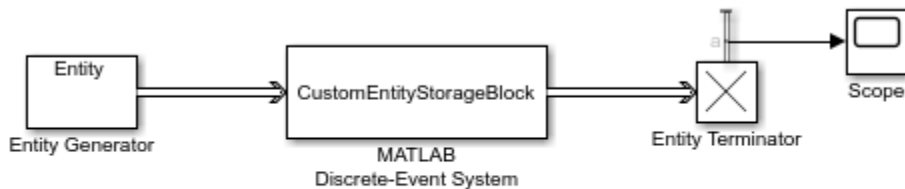

Copyright 2019 The MathWorks, Inc.

Implement the Custom Entity Storage Block with Iteration Event

This example shows how to implement a discrete-event System Object™ which represents a custom entity storage block with an iteration event. The model also includes an Entity Generator block that generates Wheels with various Diameter values.

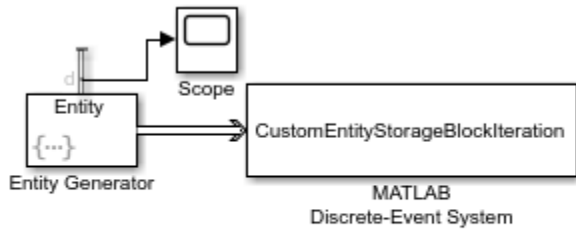

Copyright 2019 The MathWorks, Inc.

Implement the Custom Entity Storage Block with Two Timer Events

This example shows how to implement a discrete-event System Object™ which represents a custom entity storage block with two timer events. The model also includes an Entity Generator block that generates entities and two Entity Terminator blocks.

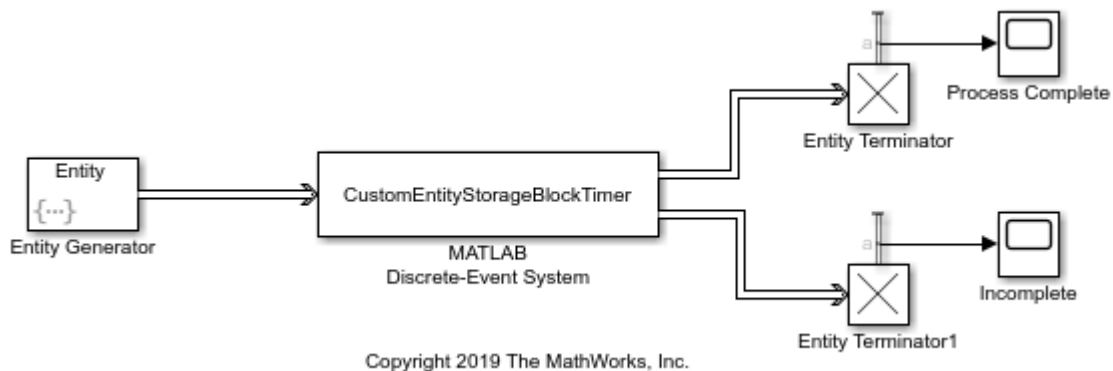

Implement the Custom Entity Generator Block

This example shows how to implement a discrete-event System Object™ which represents a custom entity generator block. The custom generator block also assigns priority values and data to each generated entity. The priority values are acquired from the incoming signal from the Ramp block. The model also includes an Entity Terminator block.

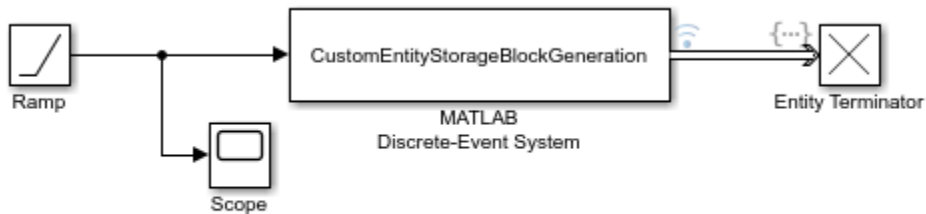

Copyright 2019 The MathWorks, Inc.

Implement the Custom Entity Storage Block with Two Storages

This example shows how to implement a discrete-event System Object™ which represents a custom entity storage block with two storages. The model also includes two Entity Generator blocks to generate two types of entities and an Entity Terminator block.

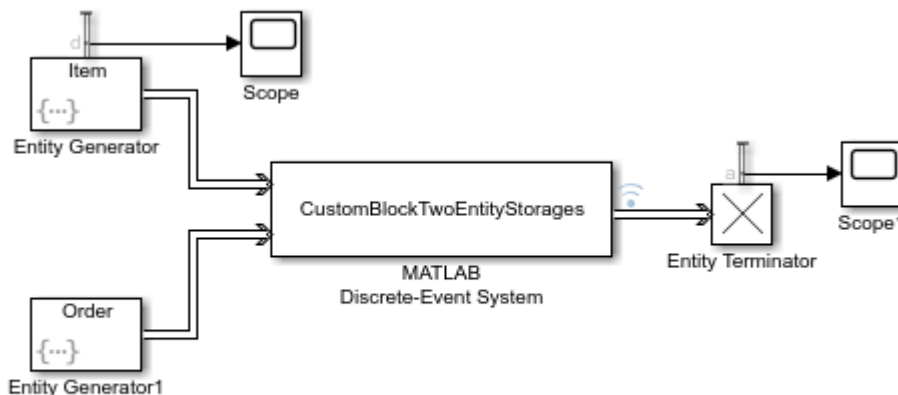

Copyright 2019 The MathWorks, Inc.

Use SimEvents with Simulink

- “Working with SimEvents and Simulink” on page 7-2
- “Solvers for Discrete-Event Systems” on page 7-6
- “Model Simple Order Fulfilment Using Autonomous Robots” on page 7-9

Working with SimEvents and Simulink

You can exchange data between SimEvents and Simulink environments. However, time-based signals and SimEvents signals have different characteristics.

Exchange Data Between SimEvents and Simulink

Use Simulink Function blocks in SimEvents models:

- To read or write attributes of entities.
- To send messages that trigger other events.
- To exchange data between event and time domain sections of a model.

Use Message Send and Receive blocks to send and receive messages between Simulink and SimEvents blocks.

Time-Based Signals and SimEvents Block Transitions

Time-based signals and SimEvents signals have different characteristics. Here are some indications that a time-based signal is automatically converted into a SimEvents signal, or conversely:

- You want to connect a time-based signal to an input port of a SimEvents block.
- You are using data from a SimEvents block to affect time-based dynamics.
- You want to perform a computation involving both time-based signals and SimEvents output.

When the transition occurs, a capital **E** appears on the line.

SimEvents Support for Simulink Subsystems

You can use SimEvents blocks (discrete-event blocks) without restriction in Simulink Virtual Subsystems, and in Simulink Nonvirtual Subsystems, observing some specific guidelines.

For more information about Simulink subsystems, see [Subsystem](#), [Atomic Subsystem](#), [Nonvirtual Subsystem](#), [CodeReuse Subsystem](#).

Discrete-Event Blocks in Virtual Subsystems

You can use discrete-event blocks without restriction in a virtual subsystem.

Discrete-Event Blocks in Nonvirtual Subsystems

When you use discrete-event blocks in an atomic subsystem, follow these guidelines:

- The entire discrete-event subsystem, which includes all discrete-event blocks, must reside entirely within the atomic subsystem. You cannot route entities into, or out of, the atomic subsystem.
- If you want to connect two or more atomic subsystems that contain discrete-event blocks, each atomic subsystem must meet all the preceding conditions.

For more information about atomic subsystems, see [Subsystem](#), [Atomic Subsystem](#), [Nonvirtual Subsystem](#), [CodeReuse Subsystem](#).

Discrete-Event Blocks in Variant Subsystems

You can use discrete-event blocks in a variant subsystem. The software permits both entities and time-based signals to enter and depart a virtual variant.

However, if you use an atomic subsystem as a variant, or within a variant, then that atomic subsystem must obey the rules for using discrete-event blocks in nonvirtual subsystems. These rules are described in “Discrete-Event Blocks in Nonvirtual Subsystems” on page 7-3. An atomic subsystem is the only type of nonvirtual subsystem that can contain discrete-event blocks, even when the nonvirtual subsystem is contained within a variant subsystem.

The SimEvents software does not support the selection of the **Analyze all choices during update diagram and generate preprocessor conditionals** check box for these blocks:

- Variant Subsystem
- Variant Sink
- Variant Source

Save Simulation Data

Behavior of the To Workspace Block

The To Workspace block writes event-based signals to the MATLAB workspace when the simulation stops or pauses. One-way to pause a running simulation is to select **Simulation > Pause**.

Send Queue Length to the Workspace

The example shows one way to write the times and values of signals to the MATLAB workspace. In this case, the signal is the **n** output from an Entity Queue block, which indicates how many entities the queue holds.

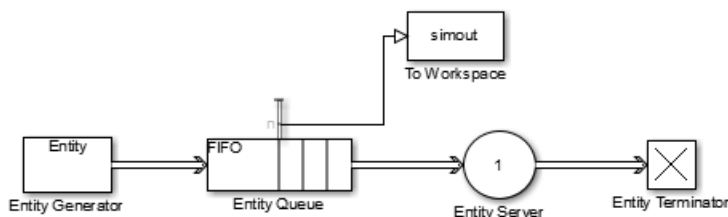

You can use different time formats in the To Workspace block to display the data.

To record entities and their attributes passing along an entity line, consider connecting a To Workspace block to that entity line.

Data Logging

You can log data from your SimEvents model using Simulink. For more information, see “Save Run-Time Data from Simulation” (Simulink).

See Also

Message Receive | Message Send | Simulink Function

Related Examples

- “Create a Hybrid Model with Time-Based and Event-Based Components”
- “Events and Event Actions” on page 1-2

- “Generate Entities When Events Occur” on page 1-12

More About

- “Solvers for Discrete-Event Systems” on page 7-6

Solvers for Discrete-Event Systems

In this section...
“Variable-Step Solvers for Discrete-Event Systems” on page 7-6
“Fixed-Step Solvers for Discrete-Event Systems” on page 7-7

Depending on your configuration, you can use both variable-step and fixed-step solvers with discrete-event systems. To choose solver settings for your model, navigate to the **Solver** pane of the model Configuration Parameters dialog box.

When choosing a solver type for your model, use the following guidelines:

- If your model contains only event-based computation and excludes continuous and discrete time-based computation, choose the variable-step, discrete solver. In this case, if you select a variable-step continuous solver, the software detects that your model does not contain any blocks with continuous states (Simulink blocks) and automatically switches the solver to discrete (no continuous states). When the software makes this change, it notifies you with a message in the MATLAB command window.
- If your discrete-event system is within a Simulink model that also contains time-based modeling, choose either a variable-step or fixed-step solver, depending on your simulation requirements. For each solver type, the following sections describe the behavior of discrete-event systems when contained within such models.

Variable-Step Solvers for Discrete-Event Systems

If your discrete-event system is within a Simulink model that contains time-based modeling, and you choose a variable-step solver for the model, the Simulink solver has a major time step each time the discrete-event system processes events.

The following graphic illustrates the behavior of the variable-step solver when used with a discrete-event system contained within a Simulink model.

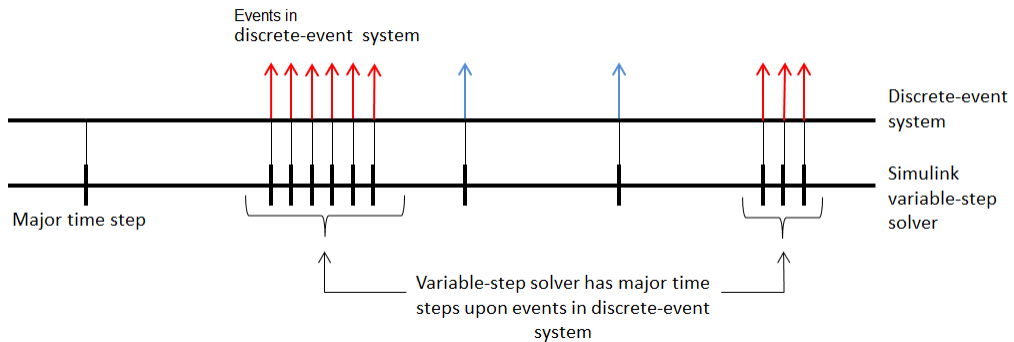

Fixed-Step Solvers for Discrete-Event Systems

If you have a discrete-event system within a Simulink model that includes time-based modeling, you can choose a fixed-step solver for the model.

When you use a fixed-step solver, the simulation still executes events in the discrete-event system at the times at which they occur. However, these events do not cause the Simulink solver to have sample hits at those times. The software insulates the discrete-event system from the time-based portions of the Simulink model.

The following graphic illustrates the behavior of the fixed-step solver when used with a discrete-event system.

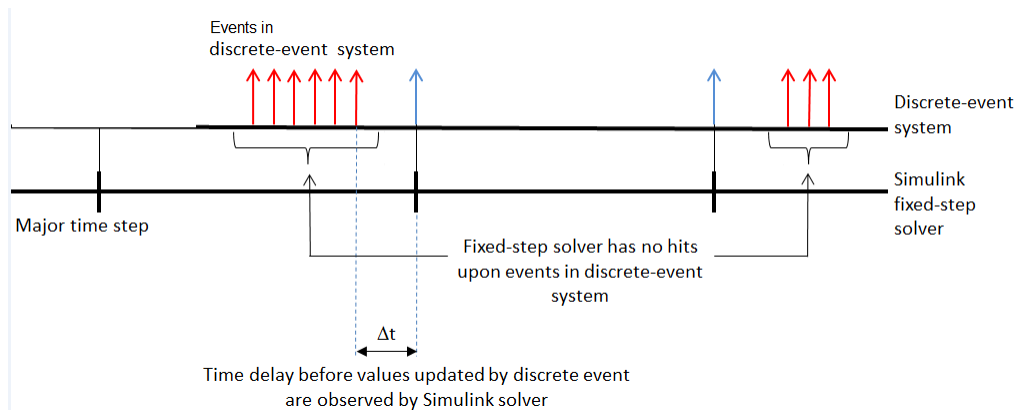

See Also

More About

- “Compare Solvers” (Simulink)
- “Working with SimEvents and Simulink” on page 7-2

Model Simple Order Fulfilment Using Autonomous Robots

This example models a warehouse with autonomous robots for order management. The goal of the example is to show how to facilitate complex models created with Simulink, Stateflow, and SimEvents components and their communication via messages. See “View Differences Between Stateflow Messages, Events, and Data” (Stateflow) for more information about messages.

Order Fulfilment Model

Order fulfilment model has two major components

- The Order Queue component represents an online order queue with the blocks from the SimEvents® library.
- The Warehouse component represents delivery of order items by autonomous robots. It uses blocks from Simulink® and SimEvents® libraries and a Stateflow® chart. The chart requires a Stateflow® license.

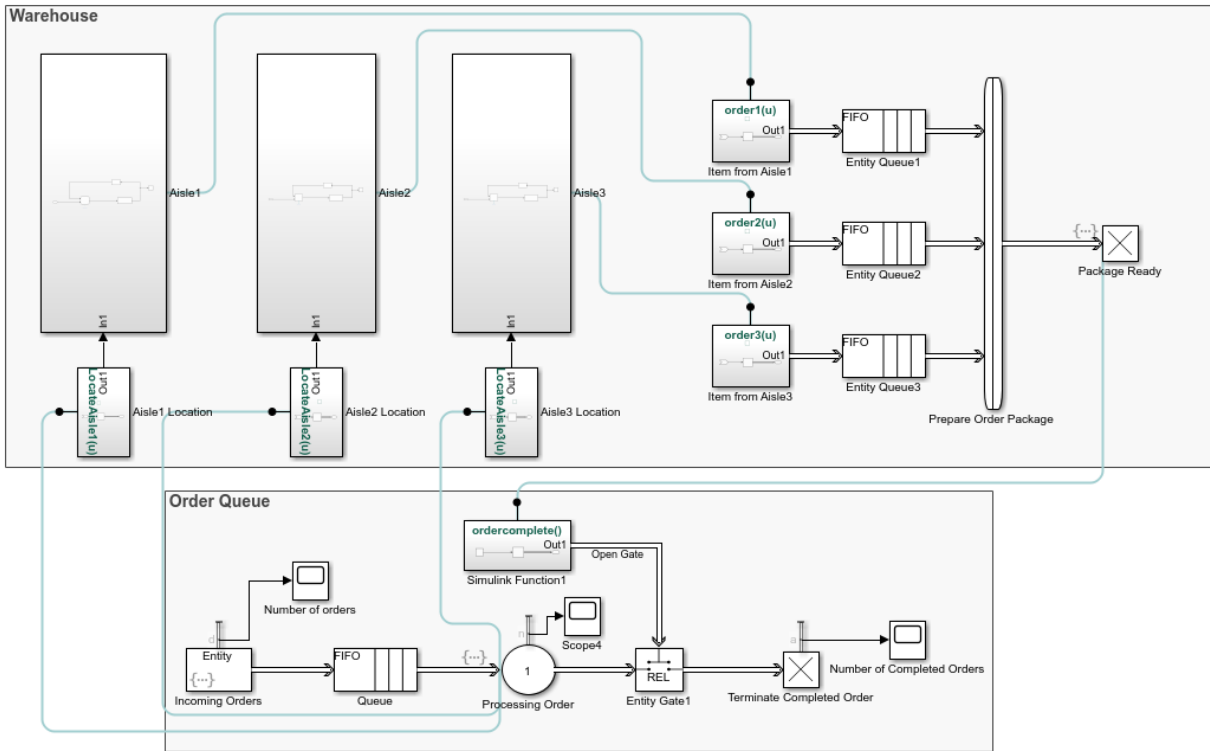

In this model, an online order for multiple items arrives at the Order Queue component. The locations of the ordered items are communicated from the Processing Order block to the autonomous robots in the Warehouse component. Three robots are assigned to three aisles. A robot picks up an item from its aisle location and returns it to its initial location for delivery. An order can have one, two, or three items. When all ordered items are delivered by the robots, the order is complete and a new order arrives. Until an order is complete, no new orders are received to the Order Queue component.

Warehouse Component

The warehouse has three aisles. The first aisle contains clothing items, the second aisle contains toys, and the third aisle contains electronics. Three delivery robots are identical and their dynamics are driven by a linear time-invariant system that is controlled by a tuned PID controller. For instance, the Aisle1 subsystem block consists of a Robot1 subsystem and a Discrete-Event Chart block as a scheduler.

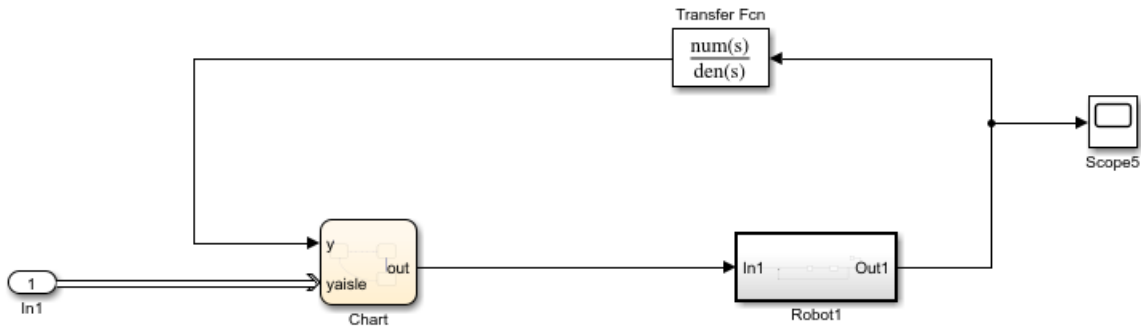

Robot1 Subsystem

The Robot1 subsystem has a generic feedback control loop with the dynamics of the robot represented by the State-Space block and the PID controller.

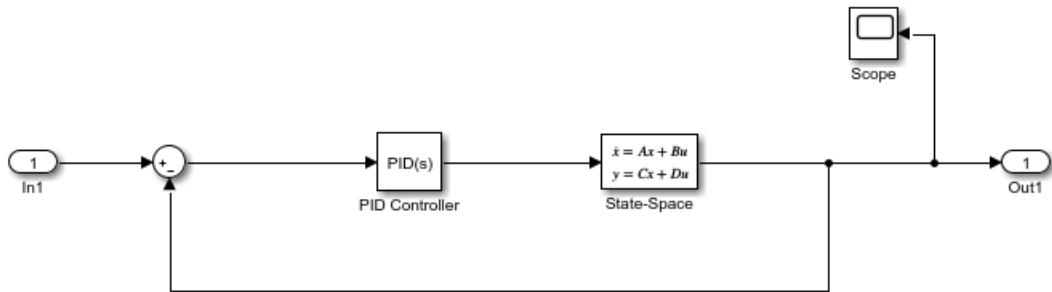

The Robot1 subsystem is designed to track a reference signal from the In1 block, which is the out signal from the Discrete-Event Chart block. The system compares the input value with the output from the State-Space block and the difference between signals is fed to the PID Controller block.

For instance, if the signal from the In1 block is a constant with value 10, starting from the initial state 0, the output of the system converges to 10.

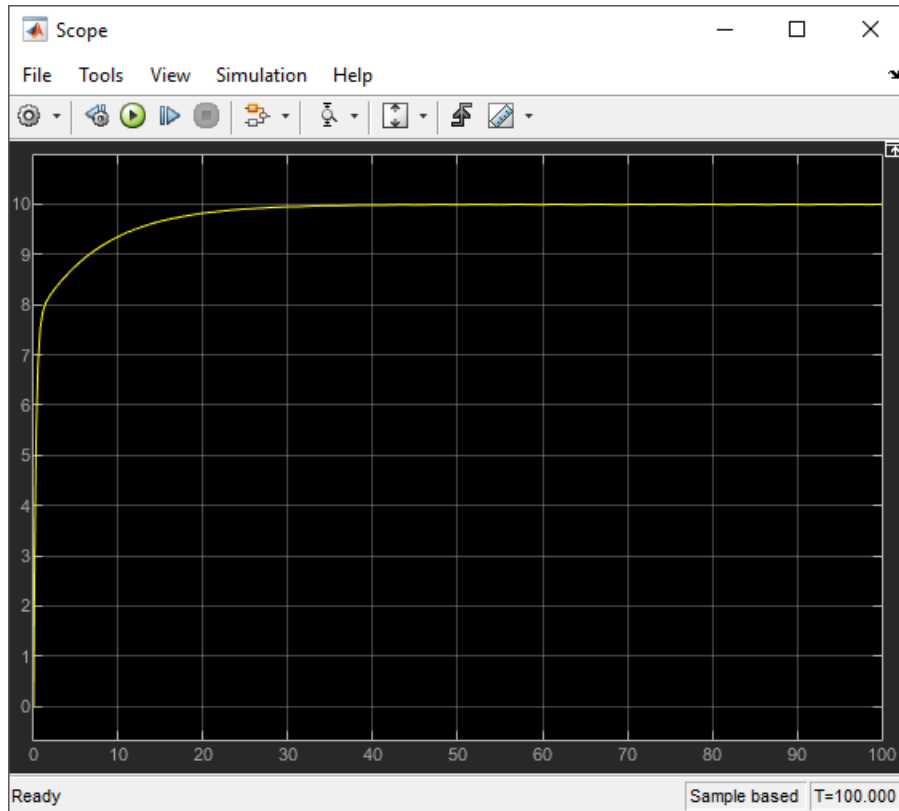

In the x -axis and y -axis, Robot1 moves as follows.

- Robot1 is initially at $x1$ and $y1 = 0$ coordinate. For item pickup and delivery, it moves only on the y -axis and its $x1$ coordinate remains the same.
- Each order item in Aisle1 has a *aisle* coordinate on the y -axis. *aisle* becomes the constant input reference signal to be tracked by Robot1 subsystem.
- When Robot1 subsystem reaches *aisle*, it picks up the order item and autonomously reruns back to $y1 = 0$ location for delivery.

The scope displays an example trajectory for Robot1 subsystem, which receives a *aisle* value 10 as the constant reference input at simulation time 265. When the distance between the robot's location and $y = 10$ is 0.1, reference input signal is 0 and the robot returns to its initial location for delivery.

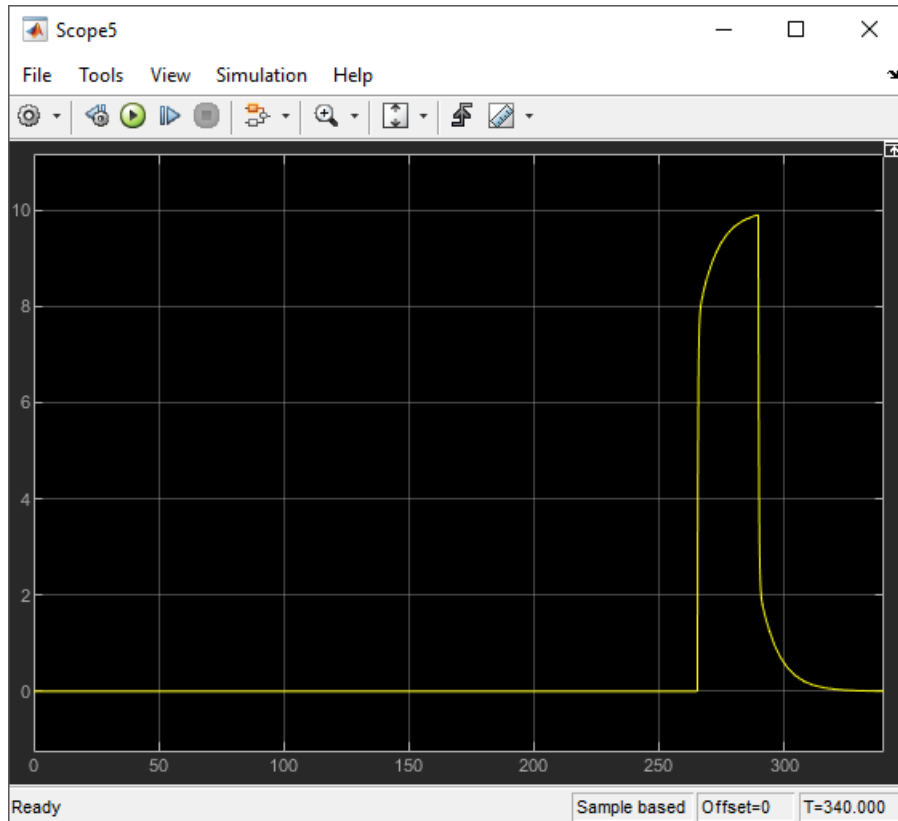

Robot2 subsystem and Robot3 subsystem have identical dynamics and behavior for the item delivery in Aisle2 subsystem and Aisle3 subsystem. Their x coordinates are x_2 and x_3 and they also move on the vertical y -axis.

Scheduler

In the previous example trajectory, Robot1 has three states. The Discrete-Event Chart block is used to schedule the transitions between these robot states.

- A robot waits in the `Wait` state, until it receives a `yaisle` item coordinate. Robot1 subsystem is in the `Wait` state, until the simulation time is 265.
- A robot transitions to the `PickUp` state, when there is an incoming message carrying the `yaisle` value of an item to the Discrete-Event Chart block. This value is assigned to `out`, which is the output signal from the Discrete-Event Chart block. The `out` signal is

fed to the Robot1 subsystem as the input signal In1 to be tracked and the robot moves towards the *yaisle* item location. Robot1 subsystem transitions to the *PickUp* state at time 265.

- When a robot is 0.1 units away from *yaisle*, it picks up the item. Then, the robot transitions to a *Deliver* state. The out signal becomes 0 and the robot returns back to $y = 0$ for delivery. At the simulation time 290, Robot1 subsystem is 0.1 unit away from $y = 10$ and transitions to the *Deliver* state.
- When a robot returns and it is 0.1 units away from $y = 0$, it transitions to the *Wait* state. At around 320, Robot1 subsystem delivers the item and transitions back to the *Wait* state.

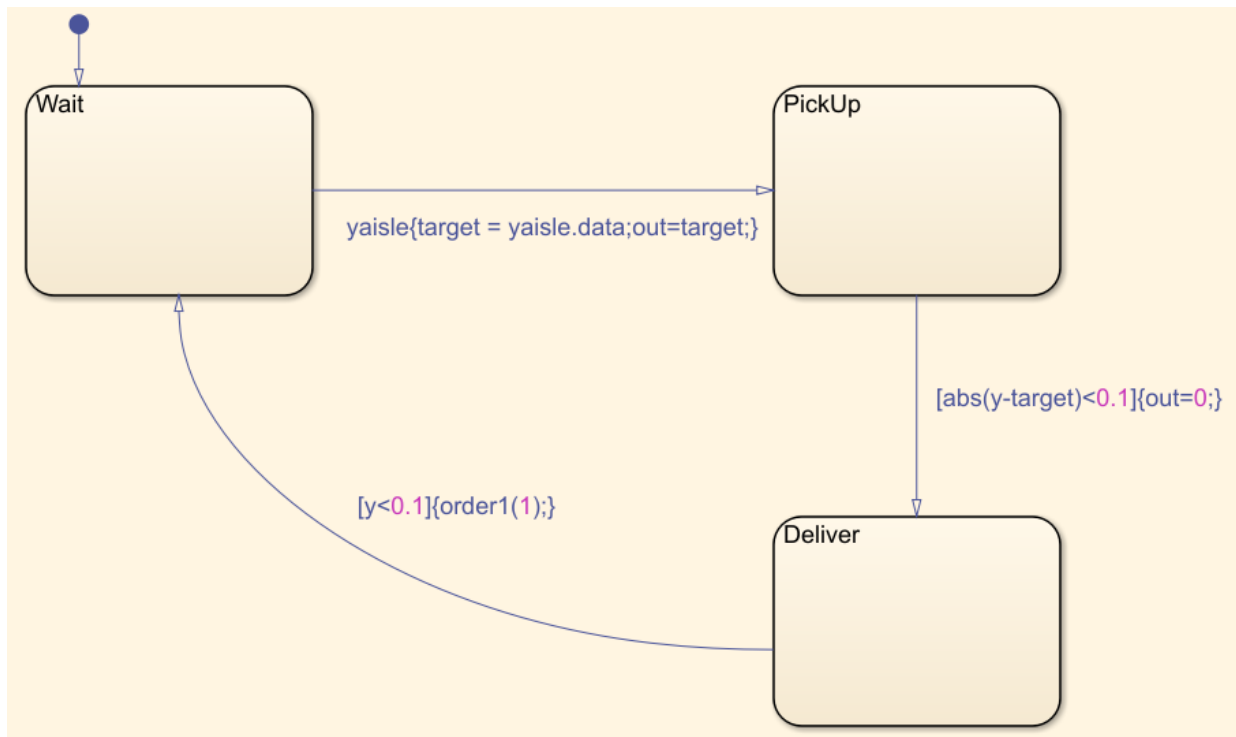

Order Package Preparation

- 1 When a robot delivers its item, the item is sent to generate the order package. This behavior is represented by the Message Send block that generates a message inside

the Item from Aisle Simulink Function block. Then, the generated message enters the Entity Queue block.

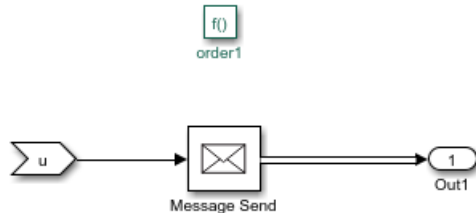

- 2 A Composite Entity Creator block waits for all three items from the three Entity Queue blocks to create a composite entity that represents the order.

To complete the order, all of the items from the three aisles are required to be delivered.

- 3 When all the items are delivered, the order is complete and it arrives at the Package Ready block.
- 4 The entry of the order to the Package Ready block triggers the Simulink Function1 block to generate a message and to open the gate for order termination.
- 5 When the order is terminated, a new order arrives at the Processing Order block which restarts the delivery process.

Until an order is complete, no new orders are received, so the robots that deliver their items wait for the order to be completed.

Order Queue Component

The order queue block is a simple queuing system composed of an Entity Generator, Entity Queue, Entity Server, Entity gate, and Entity Terminator block. For more information about creating a simple queuing system, see “Manage Entities Using Event Actions”.

- 1 Entity Generator block randomly generates orders. The intergeneration time is drawn from an exponential distribution with mean 100.
- 2 Each generated entity has three randomly generated attributes `aisle1`, `aisle2`, and `aisle3` that represent the *yaisle* coordinates of the items in Aisle1, Aisle2, and Aisle3 subsystems.

```
entity.Aisle1 = randi([1,30]);  
entity.Aisle2 = randi([1,30]);  
entity.Aisle3 = randi([1,30]);
```

It is assumed that the items are located vertically between $y = 1$ and $y = 30$.

- 3 The arrival of the order to the Entity Server block activates the robots by communicating the items' *yaisle* coordinates. Entering this MATLAB code in the **Entry action** field.

```
LocateAisle1(entity.Aisle1);  
LocateAisle2(entity.Aisle2);  
LocateAisle3(entity.Aisle3);
```

Calling the `LocateIsle()` function communicates the *yaisle* coordinate of an item to the corresponding robot.

- 4 The order waits in the Entity Server block until the Entity Gate block opens.
- 5 When all items are delivered, the order package enters the Package Ready block and its entry calls the Simulink Function1 block through the function `ordercomplete()`. The Simulink Function1 block generates a message to open the gate.
- 6 When the gate opens, the order is terminated and a new order arrives at the Entity Server block.

Results

Inspect the order throughput from the Order Queue.

- 1 Increase the simulation time to **1000**.
- 2 Simulate the model and observe that the scope displays **7** as the total number of completed orders.

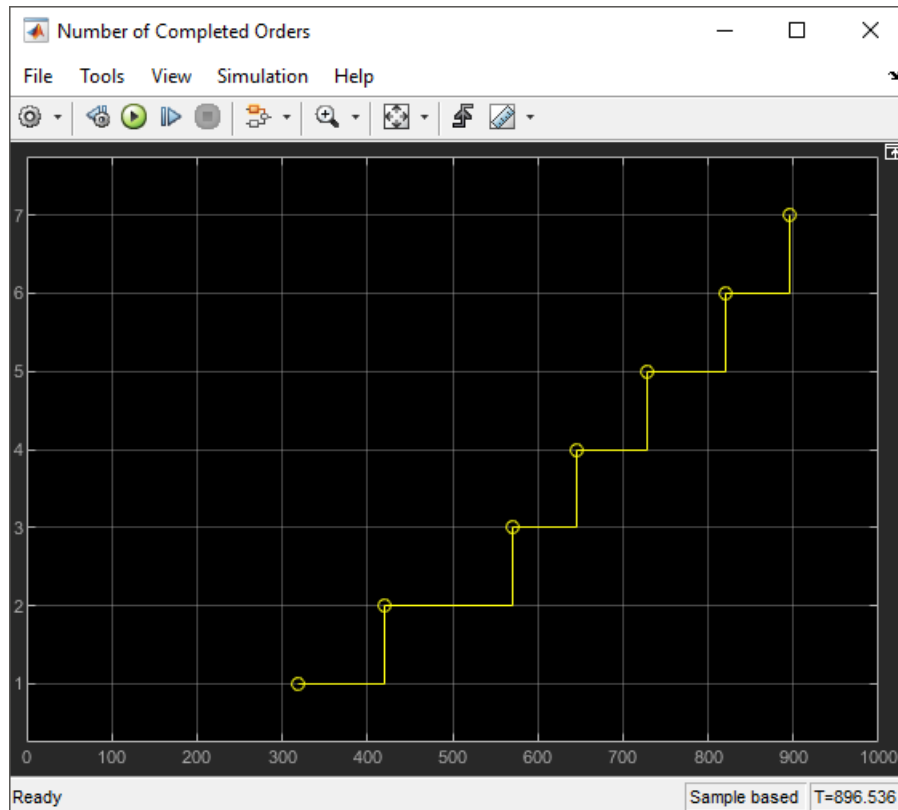

See Also

[Discrete-Event Chart](#) | [Entity Generator](#) | [Entity Queue](#) | [Entity Server](#) | [Entity Terminator](#)

Related Examples

- “Create a Hybrid Model with Time-Based and Event-Based Components”

More About

- “Working with SimEvents and Simulink” on page 7-2
- “Solvers for Discrete-Event Systems” on page 7-6

Build Discrete-Event Systems Using Charts

- “Discrete-Event Stateflow Charts” on page 8-2
- “How Discrete-Event Charts Differ from Stateflow Charts” on page 8-4
- “Event Triggering in Discrete-Event Charts” on page 8-6
- “Discrete-Event Chart Precise Timing” on page 8-9
- “Trigger a Discrete-Event Chart Block on Message Arrival” on page 8-13
- “Dynamic Scheduling of Discrete-Event Chart Block” on page 8-25

Discrete-Event Stateflow Charts

The Discrete-Event Chart block is similar to a Stateflow chart but is used for discrete events.

Why Use the Discrete-Event Chart

A Stateflow Discrete-Event Chart block can receive, process, and send SimEvents entities. Using Stateflow Discrete-Event Chart block to create SimEvents systems lets you take advantage of the graphical state transition and MATLAB action language used in Stateflow software. The Discrete-Event Chart block can be used in a similar fashion to the Stateflow Chart.

The distinguishing characteristic of the Discrete-Event Chart block is that it executes in an event-based rather than time-based fashion. The Discrete-Event Chart block provides these advantages for discrete-event modeling:

- Precise timing — The time resolution for occurrence of events can be arbitrarily precise and is not limited by the sample time of the model.

For more information, see “Discrete-Event Chart Precise Timing” on page 8-9.

- Trigger on arrival — A Discrete Event Chart block executes immediately on message arrival. It does not wait for the next sample time hit.

For more information, see “Trigger a Discrete-Event Chart Block on Message Arrival” on page 8-13.

- Variable execution order — A Discrete Event Chart block does not have a fixed sorted execution order. The order of execution depends on the run-time conditions of the model.

For more information, see “Dynamic Scheduling of Discrete-Event Chart Block” on page 8-25.

- Multiple executions per time step — A Discrete Event Chart block can execute zero or multiple times in a single time step.

For more information, see “Dynamic Scheduling of Discrete-Event Chart Block” on page 8-25.

Note With SimEvents software, you can view, edit, and simulate your Discrete Event Chart custom block within a SimEvents example model. However, to save the model you must have a Stateflow license.

For new models, without a Stateflow license, you can view and edit the model, but cannot simulate or save it.

The entities you use with discrete-event charts can be bus objects or anonymous entities.

See Also

Discrete Event Chart

Related Examples

- “Specify Properties for Stateflow Charts” (Stateflow)

More About

- “How Discrete-Event Charts Differ from Stateflow Charts” on page 8-4
- “Event Triggering in Discrete-Event Charts” on page 8-6

How Discrete-Event Charts Differ from Stateflow Charts

In this section...
“Discrete Event Chart Properties” on page 8-4
“Define Message (Entity) Input and Output” on page 8-5
“Define Local Messages” on page 8-5
“Specify Message Properties” on page 8-5

Discrete Event Chart Properties

Discrete event chart properties allow you to specify how your chart interfaces with the Simulink model.

Set Properties for a Chart

To specify properties for a single chart:

- 1 Double-click a chart.
- 2 Right-click an open area of the chart and select **Properties**.

All charts provide general and documentation properties.

- 3 Observe that the chart allows the configuration of only these properties on the **General** tab. It also supports the **Fixed-point properties** and **Documentation** tabs.

- **Name**
- **Machine**
- **Saturate on integer overflow**
- **Create data for monitoring**
- **Lock Editor**

Notes:

- SimEvents software supports only MATLAB action language
- SimEvents always supports variable-size arrays

Define Message (Entity) Input and Output

A discrete-event chart uses SimEvents entities the same way that Stateflow software uses messages. As with Stateflow charts, you can add message (entity) input and output using the Stateflow Editor or Model Explorer. Based on the desired scope, select one of the following options:

Scope	Menu Option
Input	Message (Entity) Input from Simulink
Output	Message (Entity) Output from Simulink

Define Local Messages

As with Stateflow charts, you can define local messages for the discrete-event chart using the Stateflow Editor or Model Explorer. To add a local message for the discrete-event chart, select **Chart > Add Other Elements > Local Message (Entity)...**

Specify Message Properties

Discrete-event charts have this additional property for output messages and local messages:

Message Input Port Properties	Description
Priority	If two message events occur at the same time, to decide which to process first, the discrete-event chart uses this priority. A smaller numeric value indicates a higher priority.

See Also

Discrete Event Chart

More About

- “Discrete-Event Stateflow Charts” on page 8-2
- “Event Triggering in Discrete-Event Charts” on page 8-6

Event Triggering in Discrete-Event Charts

In this section...
“Event Triggering” on page 8-6
“Message Triggering” on page 8-6
“Temporal Triggering” on page 8-7

Event Triggering

SimEvents discrete-event system charts support these events in the chart:

- Message
- Temporal
- Local
- Implicit (enter, exit, on, change)

SimEvents discrete-event system charts do not support these events in the chart:

- Conditions without event
- during, tick
- Event input from Simulink
- Event output to Simulink

Note The SimEvents event calendar displays and prioritizes message, and temporal events. Events of these types execute according to the event calendar schedule.

The event calendar does not display or prioritize local and implicit events. In the SimEvents environment, these events execute as dependent events of message or temporal events. For parallel states, local and implicit events execute in the state execution order.

Message Triggering

When a message arrives at a message input or local queue, the discrete-event chart responds to the message as follows:

- If the discrete-event chart is in a state of waiting for a message, the discrete-event chart wakes up and makes possible transitions. The chart immediately wakes up in order of message priority, processing the message with the highest priority first.
- If the discrete-event chart does not need to respond to the arriving message, the discrete-event chart does not wake up and the message is queued.

Temporal Triggering

In a discrete-event chart, you can use both event-based and absolute time-based temporal logic operators. When using absolute time-based temporal logic operators, the SimEvents software honors the specified time delay value exactly. For example, the activation of the temporal logic 'after(3, sec)' causes the chart to wake up after three seconds of simulation clock time.

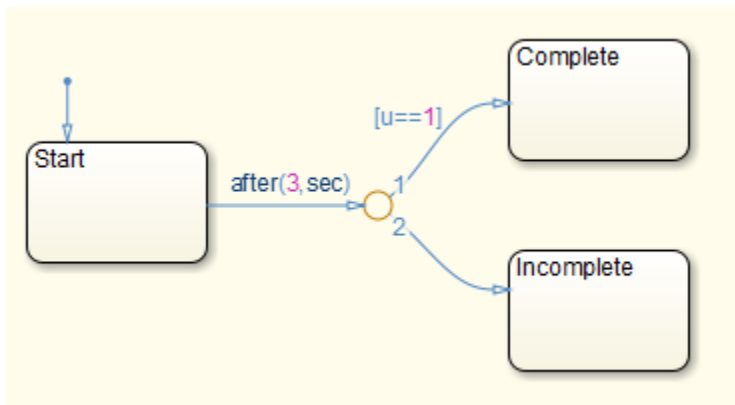

When using absolute-time temporal logic operators, observe these differences from the Stateflow environment.

Operator	Description
after	You can use as event notation in both state actions and transitions.

Operator	Description
before	When you use as event notation of a transition, you cannot use additional condition notations on this transition. You can apply a connective junction to check additional conditions, as long as the connective junction has one unconditional transition.

In conditional notation, the software supports both *after* and *before*.

See Also

Discrete Event Chart

More About

- “Discrete-Event Stateflow Charts” on page 8-2
- “How Discrete-Event Charts Differ from Stateflow Charts” on page 8-4

Discrete-Event Chart Precise Timing

This example shows the precise timing that a Discrete-Event Chart block executes as it generates parts in a facility. The behavior of the Discrete-Event Chart and the Stateflow® blocks are compared. Both blocks require a Stateflow® license. Using a Discrete-Event Chart block, the example shows that the temporal resolution of events can be arbitrarily precise and independent from the model sample time.

In this example, an entity represents a part generated in π seconds. The solver is set to Fixed-step with step size 1, and for the Stateflow® Chart block, the Enable Super Step Semantics check box is selected. For more information, see “Super Step Semantics” (Stateflow).

Model Description



Copyright 2019 The MathWorks, Inc.

In this model, the Part Generation block is created using a Discrete-Event Chart block and the Part Generation Chart is created using a Stateflow® Chart block. Both blocks contain the same state transition model, including two states, CreatePart and WaitForQA.

- The CreatePart state represents the production of a Part in π seconds.
- The WaitForQA state represents the wait for the quality control department for Part's validation.

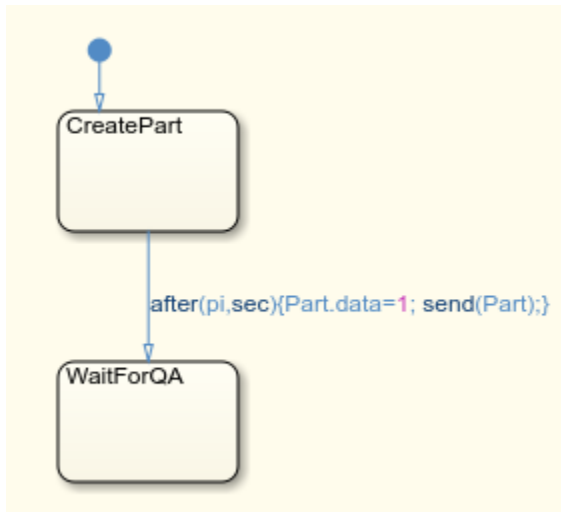

Enable the sample time annotation and simulate the model. Observe that the sample time for the Discrete-Event Chart block reflects the event-based sampling.

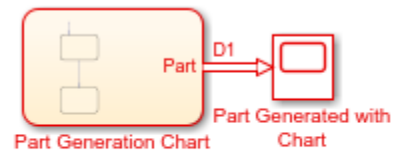
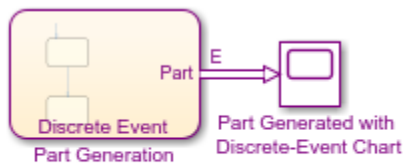

Copyright 2019 The MathWorks, Inc.

Simulation Results

Observe that Part is generated by the Discrete-Event chart after precisely 3.14 seconds, independent from the simulation step size.

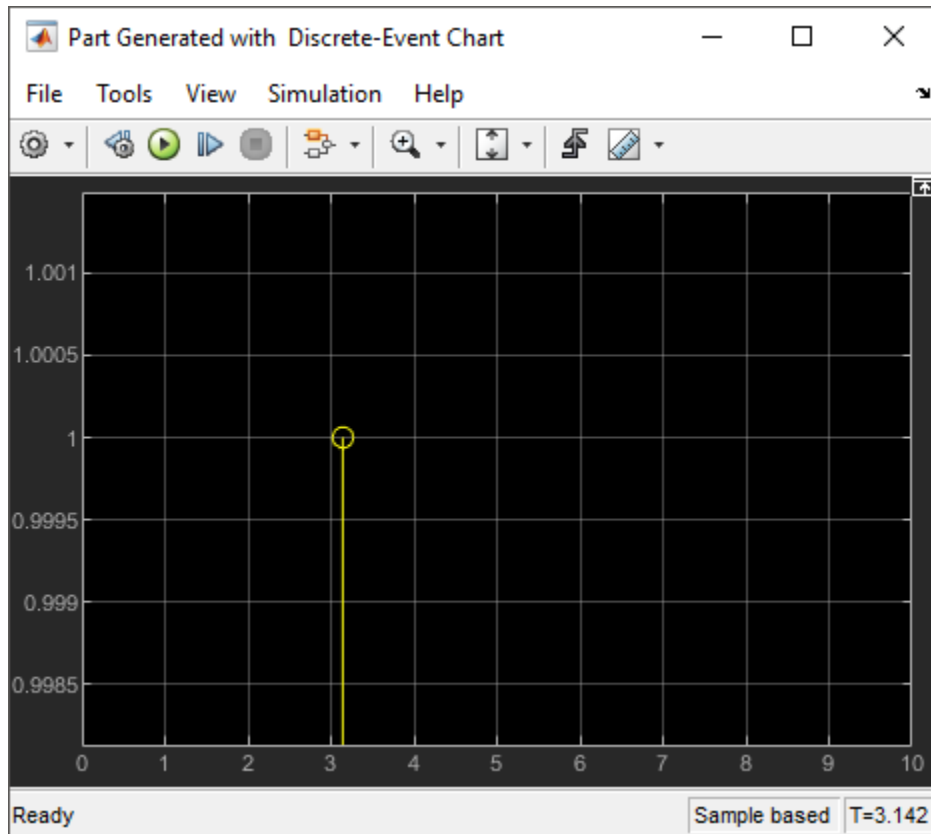

Observe that Part is generated by the Stateflow® Chart after 4 seconds. This is due to the fixed step size 1, which causes the Stateflow® Chart block to wait until the next simulation step.

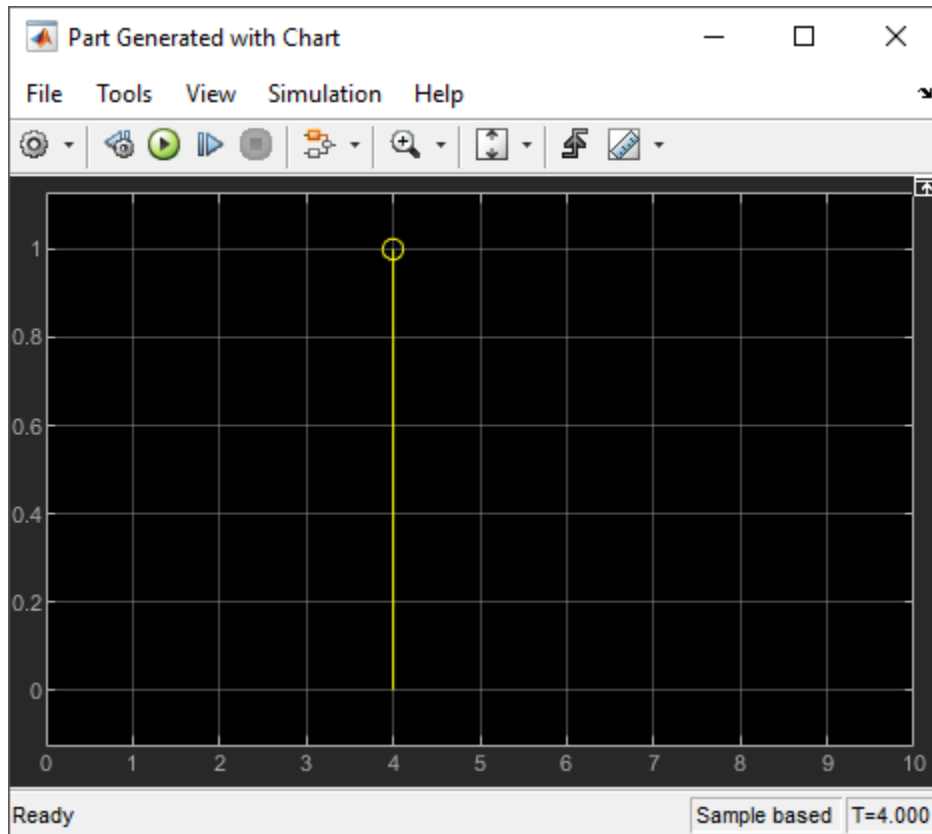

See Also

Discrete-Event Chart

More About

- "Why Use the Discrete-Event Chart" on page 8-2
- "Trigger a Discrete-Event Chart Block on Message Arrival" on page 8-13
- "Dynamic Scheduling of Discrete-Event Chart Block" on page 8-25
- "How Discrete-Event Charts Differ from Stateflow Charts" on page 8-4

Trigger a Discrete-Event Chart Block on Message Arrival

This example shows how to trigger a Discrete-Event Chart Block on the message arrival when generating parts in a facility and performing quality assurance. In the example, behaviors of a Discrete-Event Chart and Stateflow® Chart blocks are compared. Both blocks require a Stateflow® license. The example shows that, a Discrete-Event Chart block executes immediately upon the arrival of a message and does not wait for the next sample time hit.

In this example, a part is generated in the Part Generation block and it is sent to the Quality Assurance block for the Part's quality control. After the evaluation, the Quality Assurance block outputs the validated part.

The model is further modified to send the validated part back to the Part Generation block from which it is shipped to the customer. For both models in this example, the solver is set to Fixed-step with step size 1, and for all the Stateflow® Chart blocks, the Enable Super Step Semantics option is selected. For more information, see “Super Step Semantics” (Stateflow).

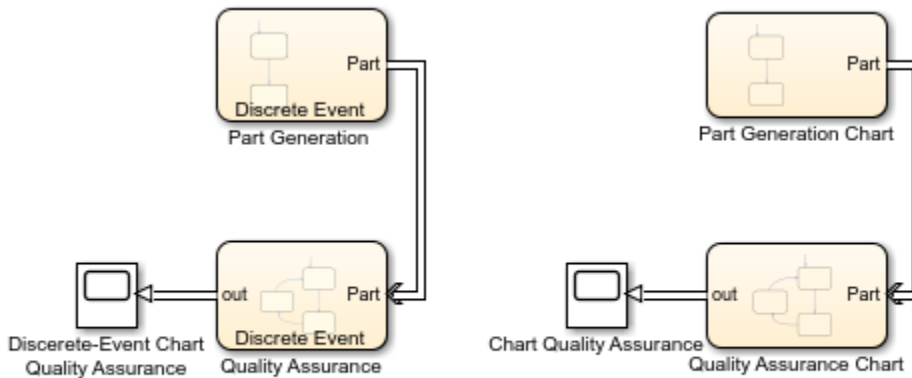

Copyright 2019 The MathWorks, Inc.

Model Description

In the PartQualityEvaluationModel model, the Part Generation is modeled by a Discrete-Event Chart block, and the Part Generation Chart is modeled by a Stateflow® Chart block. Both blocks contain the same state transition logic including two states, CreatePart and WaitForQA.

- The `CreatePart` state represents the production of a `Part` in `pi` seconds.
- The `WaitForQA` state represents the wait for the quality control department for the `Part`'s validation.

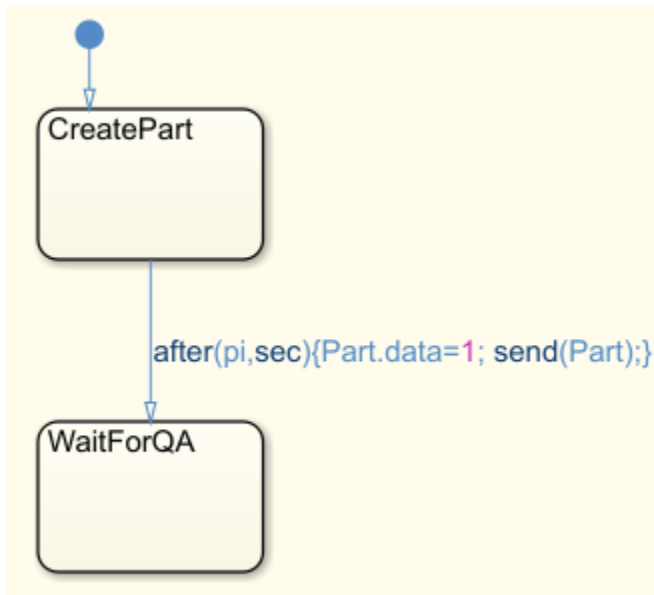

Similarly, Quality Assurance is modeled by a Discrete-Event Chart block and Quality Assurance Chart is modeled by using a Stateflow® Chart block. Both blocks contain the same state transition logic including three states, `WaitForPart`, `Evaluating`, and `Finished`.

- The `WaitForPart` state represents the wait for the generated `Part`.
- When the `Part` arrives, the block transitions to the `Evaluating` state to represent the start of the evaluation process.
- After 1 second, the evaluation is complete and the block transitions to `Finished` state.
- The `Part` departs the block and the block transitions back to the `WaitForPart` state.

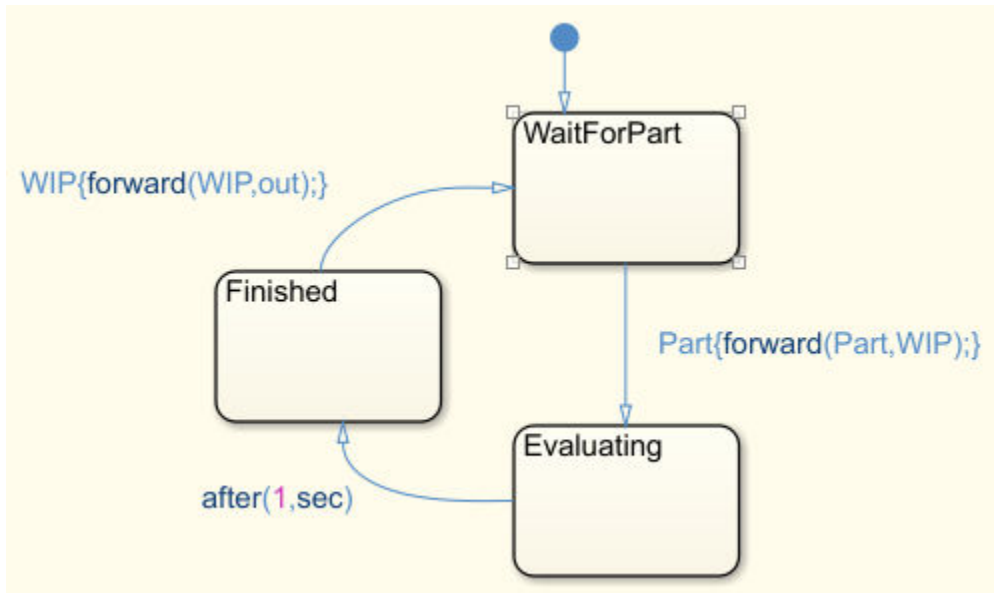

Simulation Results

Simulate the model. Observe the Scope block connected to the Quality Assurance block. The block outputs the Part after 4.14 seconds, which is the sum of 3.14 seconds required for the Part's generation and 1 s for its quality control.

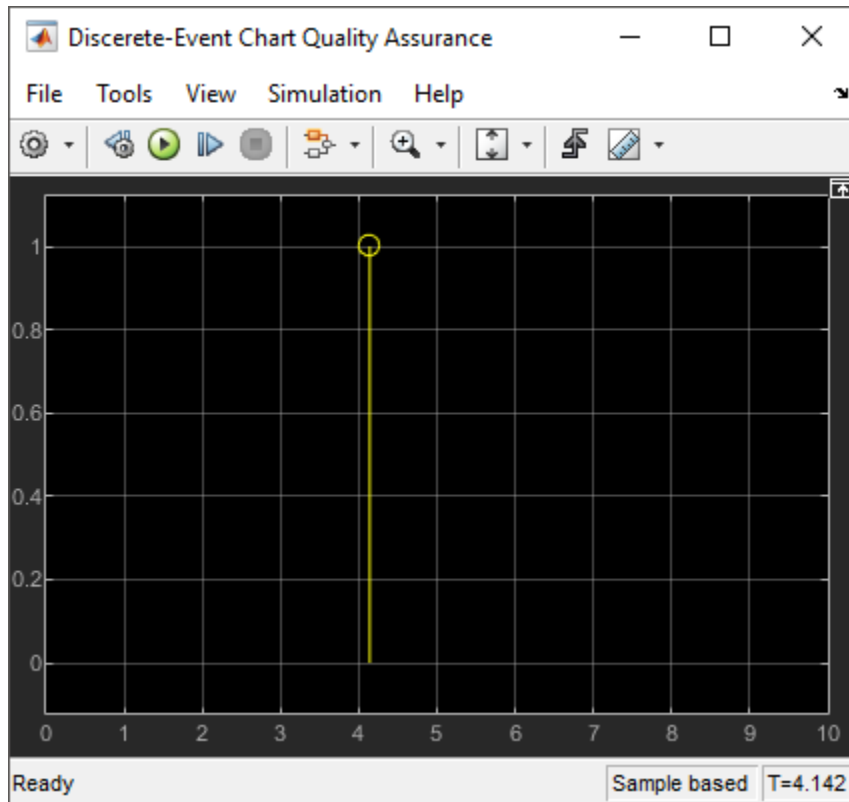

Observe the Scope block that is connected to the Quality Assurance Chart block. The block outputs the Part after 5 seconds, which is the sum of 4 seconds for the Part's generation and 1 second for its quality control as a result of fixed step size 1. This difference is based on the precise timing property of the Discrete-Event chart. For more information, see "Discrete-Event Chart Precise Timing" on page 8-9.

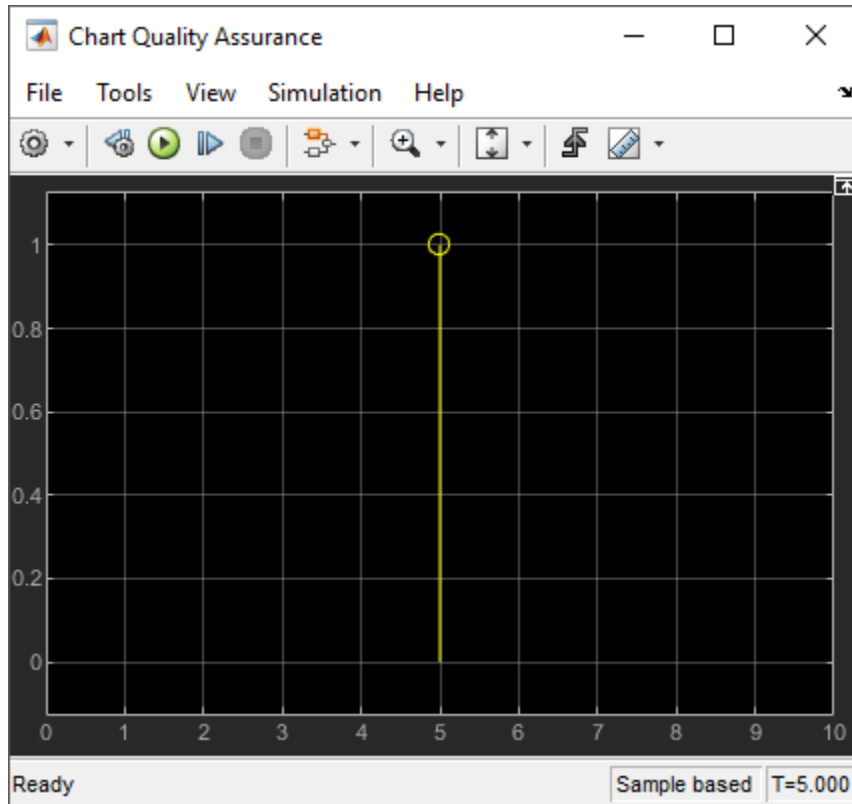

Further Modify the Model

Open PartQualityControlShip which is the modified the model that sends the processed Part back to the Part Generation block for shipment. In the PartQualityControlShip model, the modified Part Generation and Part Generation Chart blocks contain the same set of additional states and transitions.

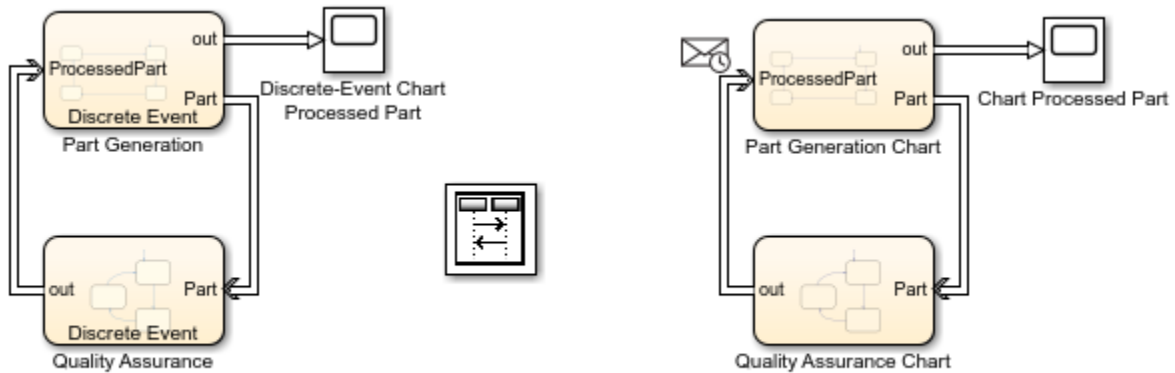

Copyright 2019 The MathWorks, Inc.

In the Part Generation and Part Generation Chart Blocks:

- The Review state represents the review of the quality control report for the ProcessedPart. When the ProcessedPart returns, the block transitions to the Review state.
- When the review is complete after $\sqrt{2}$ seconds, the block transitions to the Ship state.
- When the processed Part is shipped to the customer, the block transitions back to the CreatePart state to generate a new part.

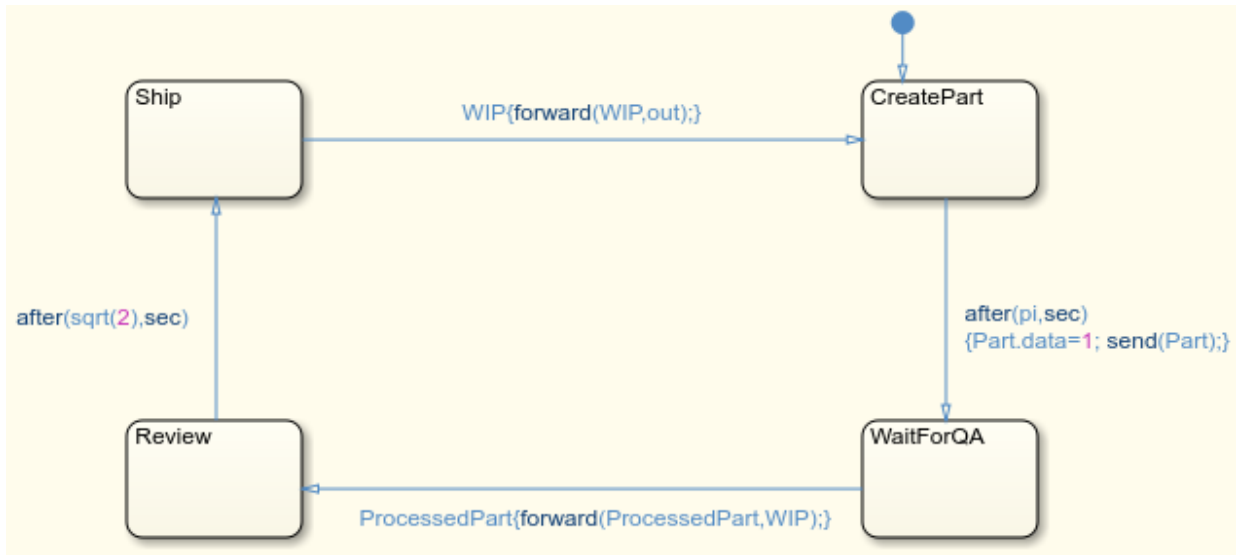

Simulation Results

Simulate the modified model. Observe that the processed Part departs the Part Generation block after 5.55 seconds, which is the sum of 4.14 required for part generation and quality control and 1.41 for the review before shipment.

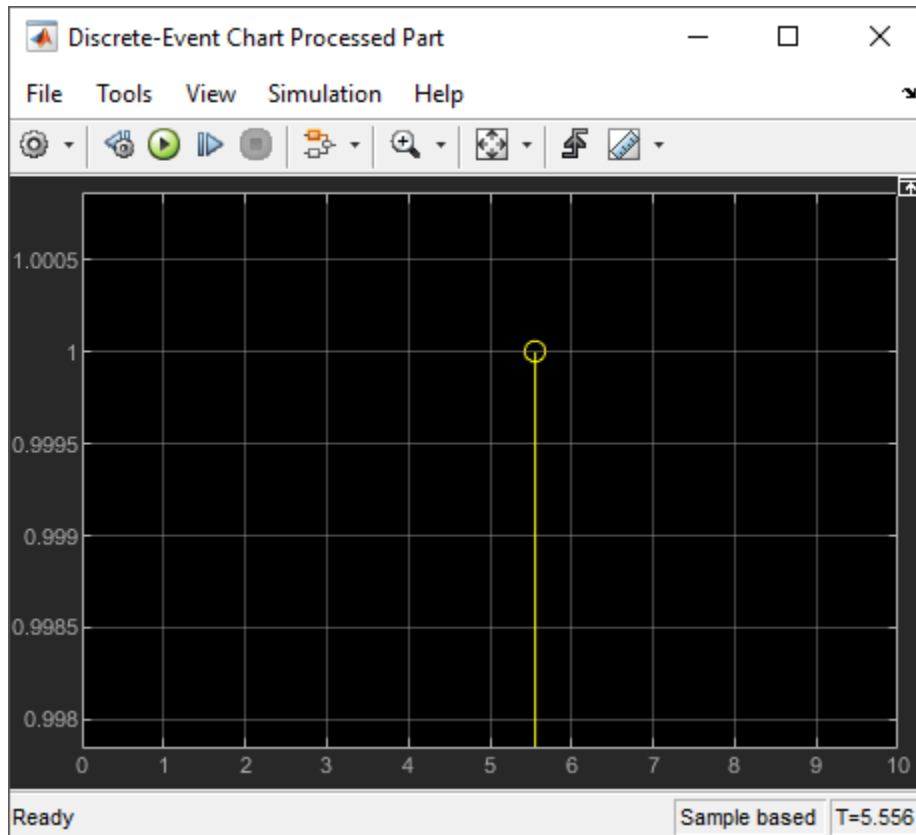

Observe that the processed Part departs the Part Generation Chart after 8 seconds, which is the sum of 5 required for part generation and quality control, 2 for the review before shipment, and 1 for the block's static scheduling.

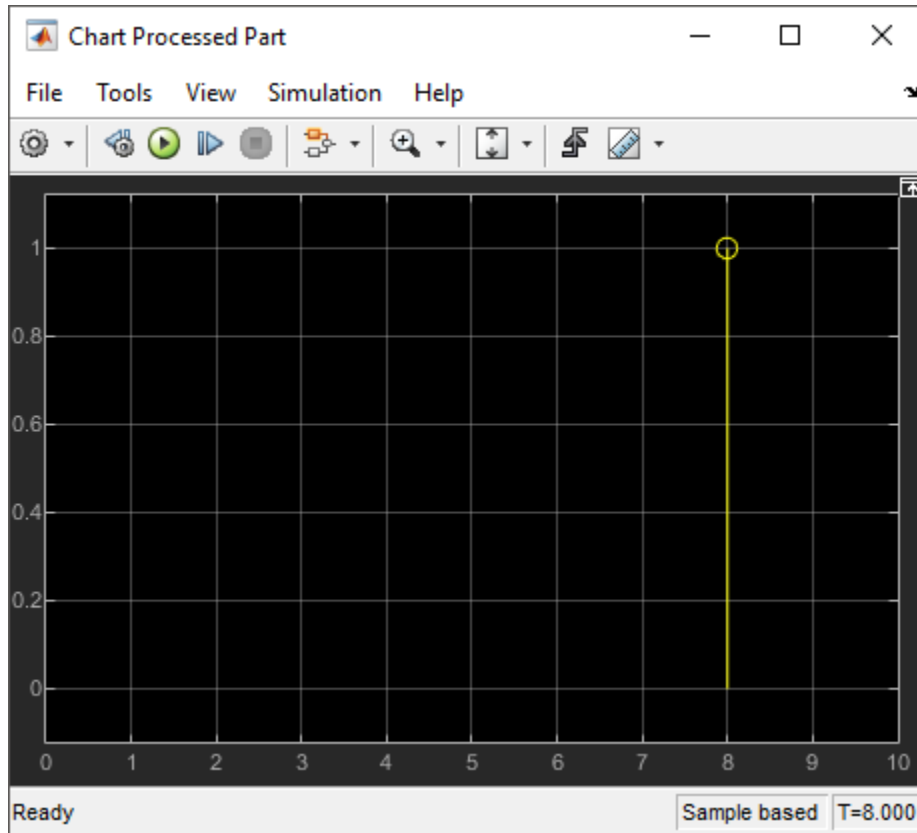

Observe the Sequence Viewer block. Each time grid row bordered by two blue lines contains events that occur at the same simulation time. The Sequence Viewer window shows events vertically, ordered in time, and uses a combination of linear and nonlinear displays. For more information, see “Use the Sequence Viewer Block to Visualize Messages, Events, and Entities” on page 5-32.

The `ProcessedPart` is sent from Quality Assurance block to Part Generation at 4.1 and the Part's arrival triggers the Discrete-Event Chart block immediately. At time 5, the `ProcessedPart` is sent from the Quality Assurance Chart to the Part Generation Chart. However, the Part Generation Chart waits for the next sample time hit at 6 after the message arrival to execute.

In the order, Part Generation Chart executes first and Quality Assurance Chart executes second in one sample time hit. That is the reason why Part Generation Chart block waits for the next sample time hit to execute as the first block in the order.

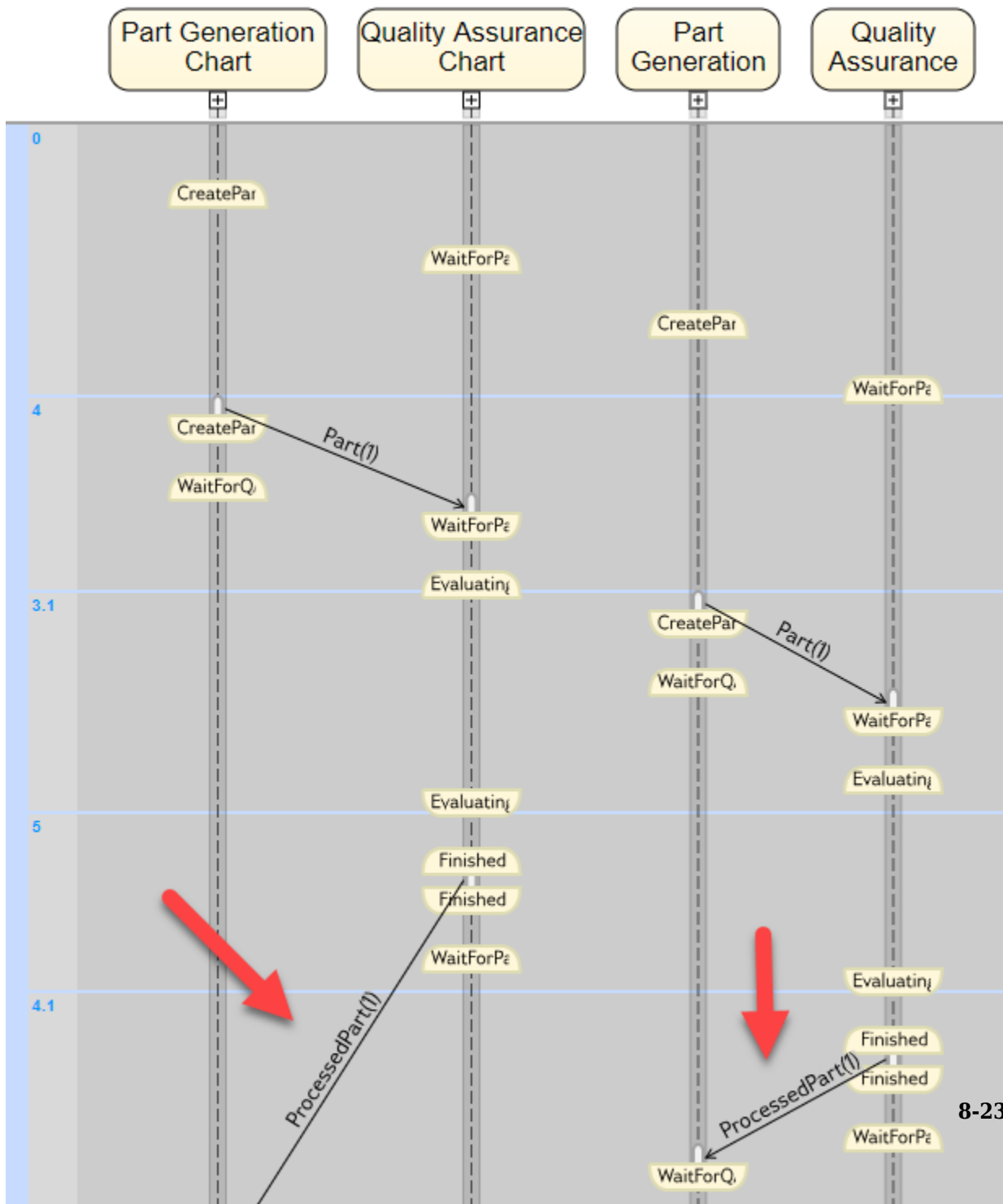

More About

- “Why Use the Discrete-Event Chart” on page 8-2
- “Discrete-Event Chart Precise Timing” on page 8-9
- “Dynamic Scheduling of Discrete-Event Chart Block” on page 8-25

Dynamic Scheduling of Discrete-Event Chart Block

This example shows how to use the dynamic scheduling that the Discrete-Event Chart block provides. A Discrete Event Chart block can execute zero or multiple times in a time step. The example compares the behaviors of the Discrete-Event Chart and Stateflow® Chart blocks. Both blocks require a Stateflow® license.

In this example, a bicycle part is generated every second by the Part Generation block. Its quality control is simultaneously performed when the part is in the assembly line. The quality control process takes 1 s to restart. This process is modeled by the Quality Assurance block.

The solver is set to *Fixed-step* with step size 1, and for all the Stateflow® Chart blocks, the *Enable Super Step Semantics* option is selected. For more information, see “Super Step Semantics” (Stateflow).

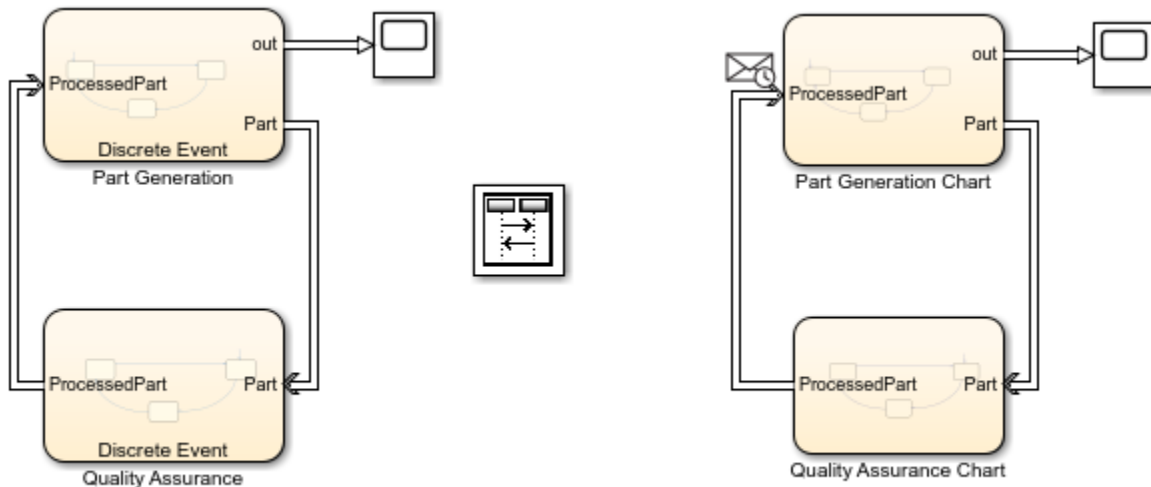

Copyright 2019 The MathWorks, Inc.

Model Description

In the model, Part Generation is modeled by a Discrete-Event Chart block and Part Generation Chart is modeled by a Stateflow® Chart block. Both blocks contain the same state transition logic including three states, *CreatePart*, *WaitForQA*, and *Ship*.

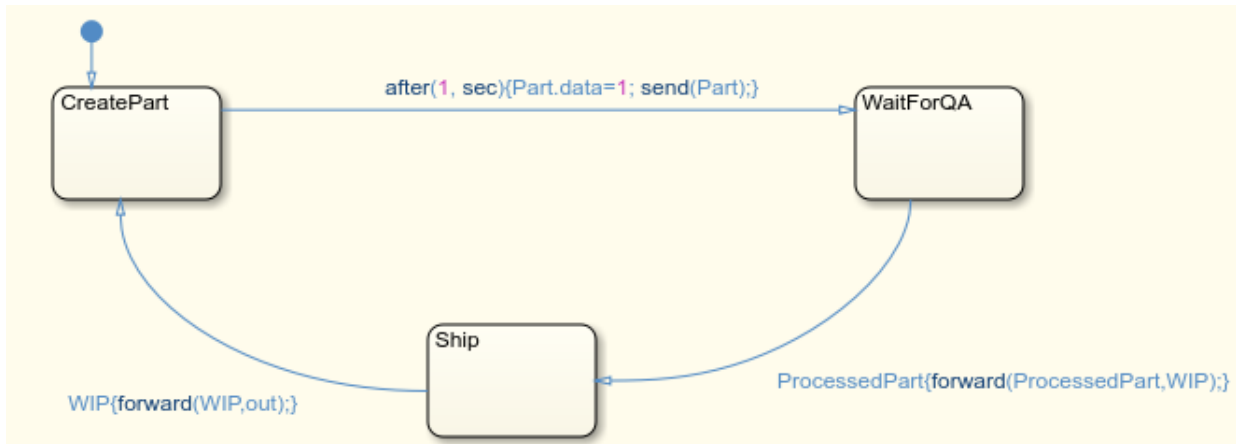

- After 1 s, a Part is generated and the Chart transitions from the CreatePart to WaitForQA.
- The quality control is simultaneous and the ProcessedPart returns back immediately. The block transitions to the Ship state and after the ProcessedPart is shipped to the CreatePart state.

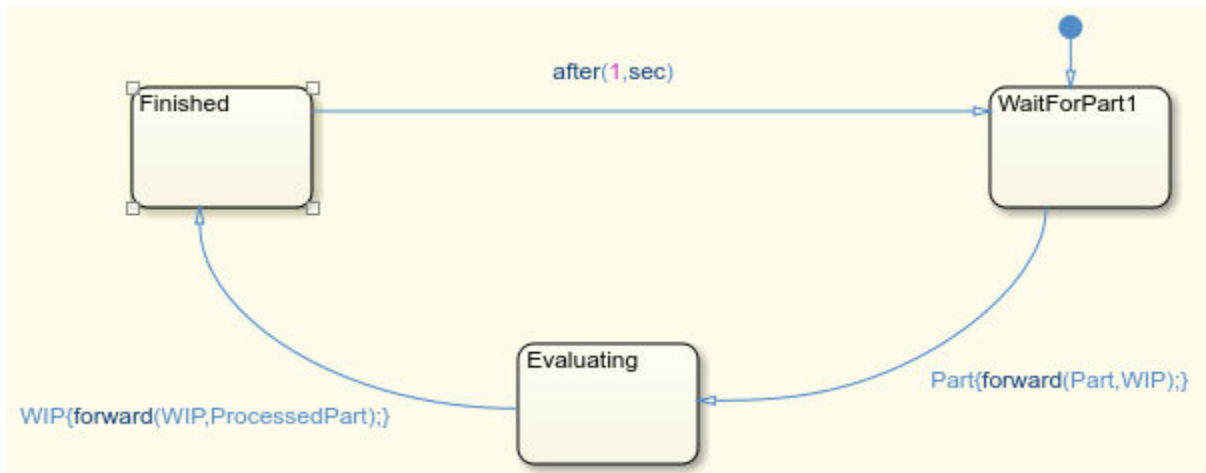

Similarly, the Quality Assurance is modeled by a Discrete-Event Chart while the Quality Assurance Chart is modeled by a Stateflow® Chart block. Both blocks contain the same state transition logic including three states, WaitForPart, Evaluating, and Finished.

- The `WaitForPart` state represents the wait for the generated Part. When the Part arrives, the block transitions to the `Evaluating` state.
- Then the `ProcessedPart` is immediately sent back to Part Generation and the block transitions to the `Finished` state.
- After 1 s, the block returns to the `WaitForPart` state.

Simulation Results

- Simulate the model. Observe the Scope block connected to the Part Generation block. The Parts depart the facility every second.

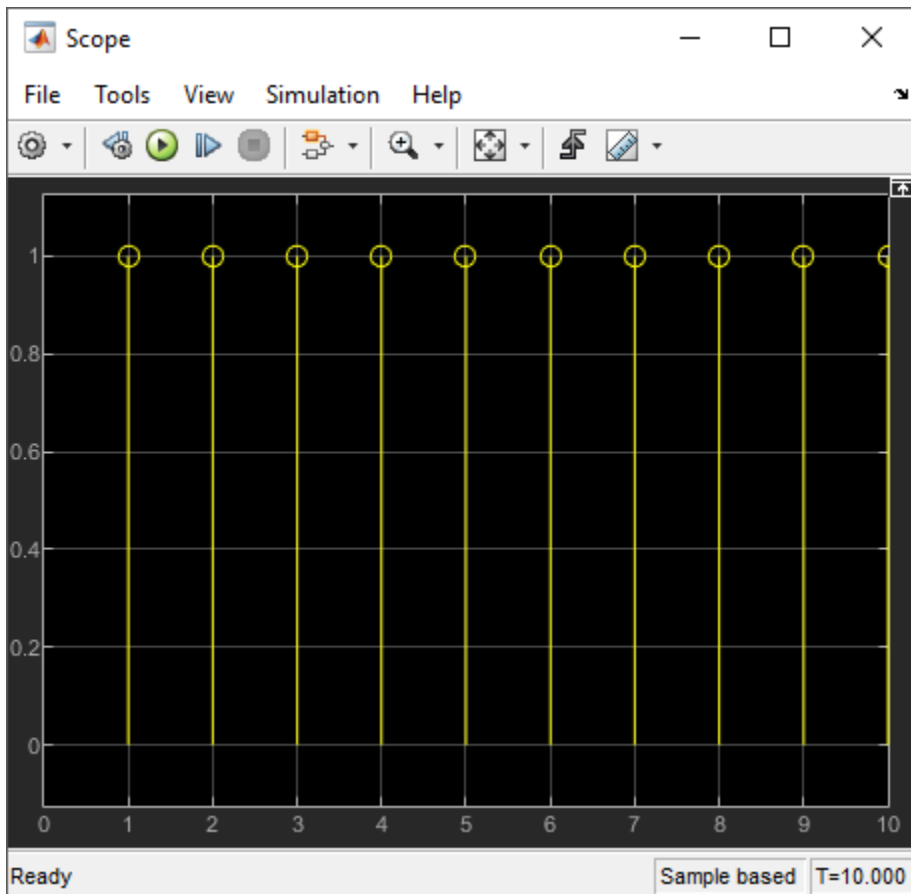

Observe the Scope block connected to the Part Generation Chart block, which displays that the parts are generated in every two seconds.

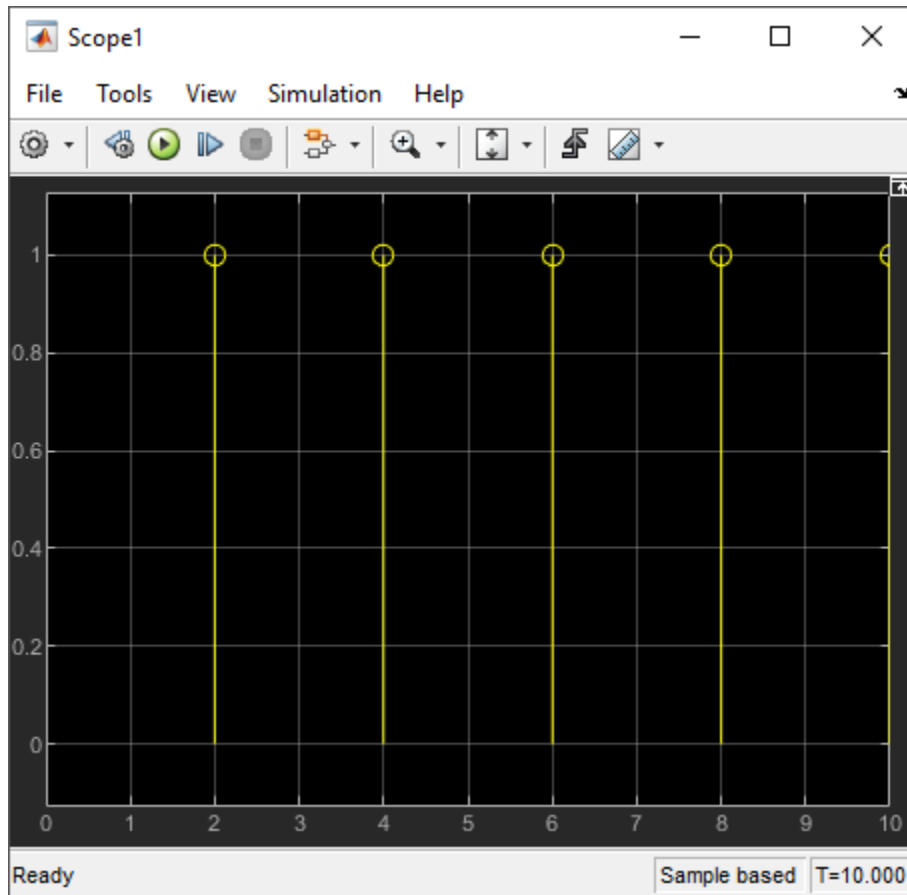

The difference is due to the dynamic scheduling property of the Discrete-Event Chart block. For instance, observe the Sequence Viewer block. Each time grid row, bordered by two blue lines, contains events that occur at the same simulation time. For more information, see “Use the Sequence Viewer Block to Visualize Messages, Events, and Entities” on page 5-32.

In the second and third simulation time step, the static scheduling of the Stateflow® Chart blocks causes their execution with a fixed order, in which the Part Generation Chart

labeled 1 is executed first and the Quality Assurance Chart labeled 2 is executed second for each time step. The sequence is 1, 1, 2 for the second time step and 1, 2, 2 for the third time step.

The dynamic scheduling property of the Discrete-Event Chart allows multiple executions of the Part Generation and Quality Assurance blocks at each time step with the changing order. For example, in the second time step, the order becomes 2, 1, 2, 2, 1, 1.

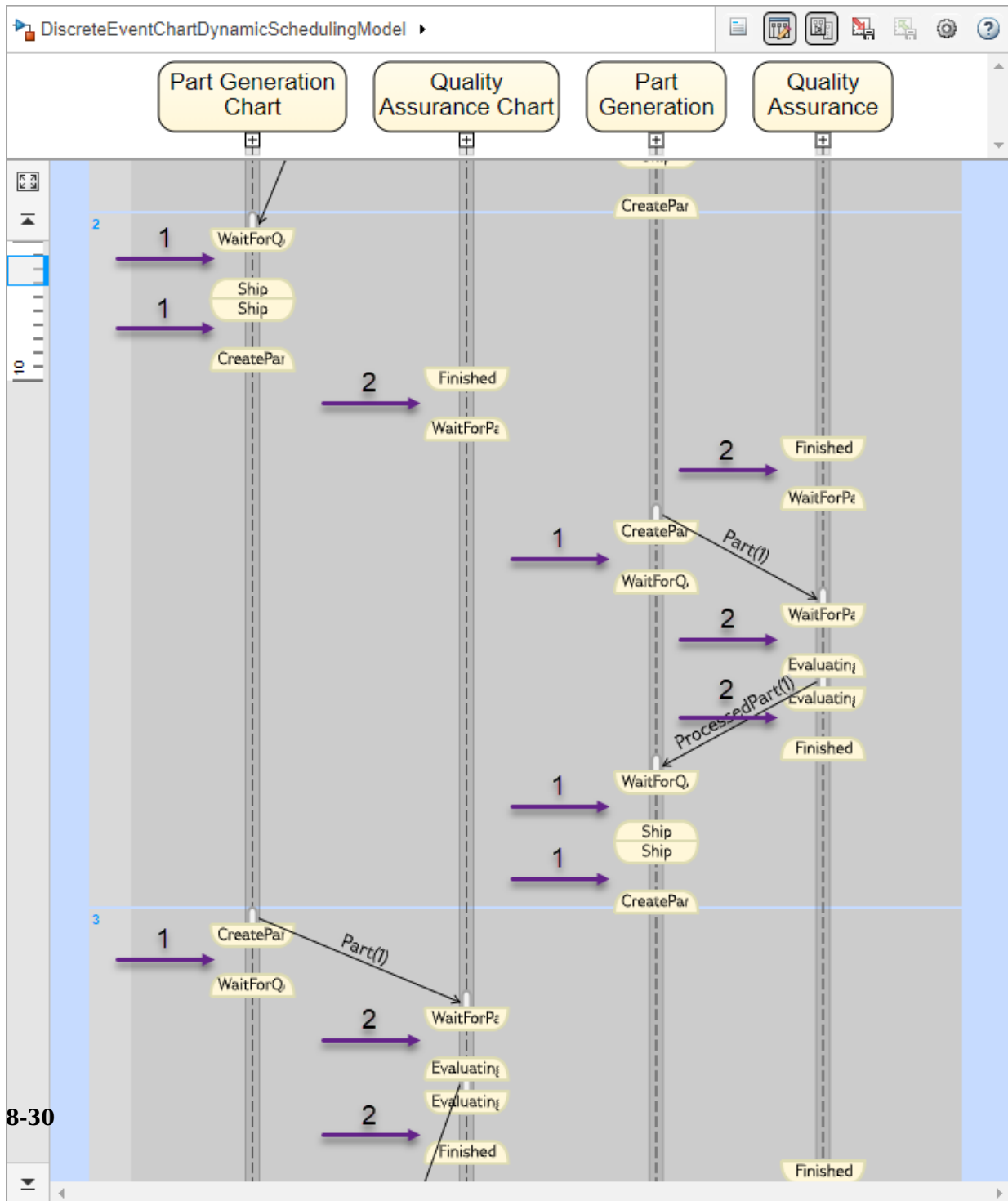

More About

- “Why Use the Discrete-Event Chart” on page 8-2
- “Discrete-Event Chart Precise Timing” on page 8-9
- “Trigger a Discrete-Event Chart Block on Message Arrival” on page 8-13

Build Discrete-Event Systems Using System Objects

- “Create Custom Blocks Using MATLAB Discrete-Event System Block” on page 9-2
- “Delay Entities with a Custom Entity Storage Block” on page 9-11
- “Create a Custom Entity Storage Block with Iteration Event” on page 9-17
- “Custom Entity Storage Block with Multiple Timer Events” on page 9-23
- “Custom Entity Generator Block with Signal Input” on page 9-31
- “Build a Custom Block with Multiple Storages” on page 9-39
- “Create a Custom Resource Acquirer Block” on page 9-49
- “Create a Discrete-Event System Object” on page 9-58
- “Generate Code for MATLAB Discrete-Event System Blocks” on page 9-65
- “Customize Discrete-Event System Behavior Using Events and Event Actions” on page 9-69
- “Call Simulink Function from a MATLAB Discrete-Event System Block” on page 9-75
- “Resource Scheduling Using MATLAB Discrete-Event System and Data Store Memory Blocks” on page 9-80

Create Custom Blocks Using MATLAB Discrete-Event System Block

In this section...
“Entity Types, Ports, and Storage in a Discrete-Event System Framework” on page 9-3
“Events” on page 9-6
“Implement a Discrete-Event System Object with MATLAB Discrete-Event System Block” on page 9-7

Discrete-Event System objects let you implement custom event-driven entity-flow systems using the MATLAB language. The MATLAB Discrete-Event System block enables you to use discrete-event System objects to create a custom block in your SimEvents model. You can author such discrete-event System objects via a set of MATLAB methods.

You can create a custom discrete-event System object from scratch that:

- Contains multiple entity storage elements, with each storage element containing multiple SimEvents entities, and configure it to sort entities in a particular order.
- Has an entity or a storage element that can schedule and execute multiple types of events. These events can model activities such as entity creation, consumption, search, transmission, and temporal delay.
- Can accept entity/signal as input/output, produce entity and signal as outputs, and support both built-in data types and structured/bus data types.
- Use MATLAB toolboxes for computation and scaling of complex systems.

The MATLAB Discrete-Event System block is similar to the MATLAB System block with these differences:

- The resulting discrete-event System object is an instantiation of the `matlab.DiscreteEventSystem` class rather than the `matlab.System` class.
- The `matlab.DiscreteEventSystem` has its own set of System object methods particular to discrete-event systems.
- The `matlab.DiscreteEventSystem` also inherits a subset of the MATLAB System methods. For a complete list of this subset, see “Create a Discrete-Event System Object” on page 9-58.

Entity Types, Ports, and Storage in a Discrete-Event System Framework

An entity is a discrete object that the system processes. An entity has a type and the entity type defines a class of entities that share a common set of data specifications and run-time methods. Examples of data specifications include dimensions, data type, and complexity.

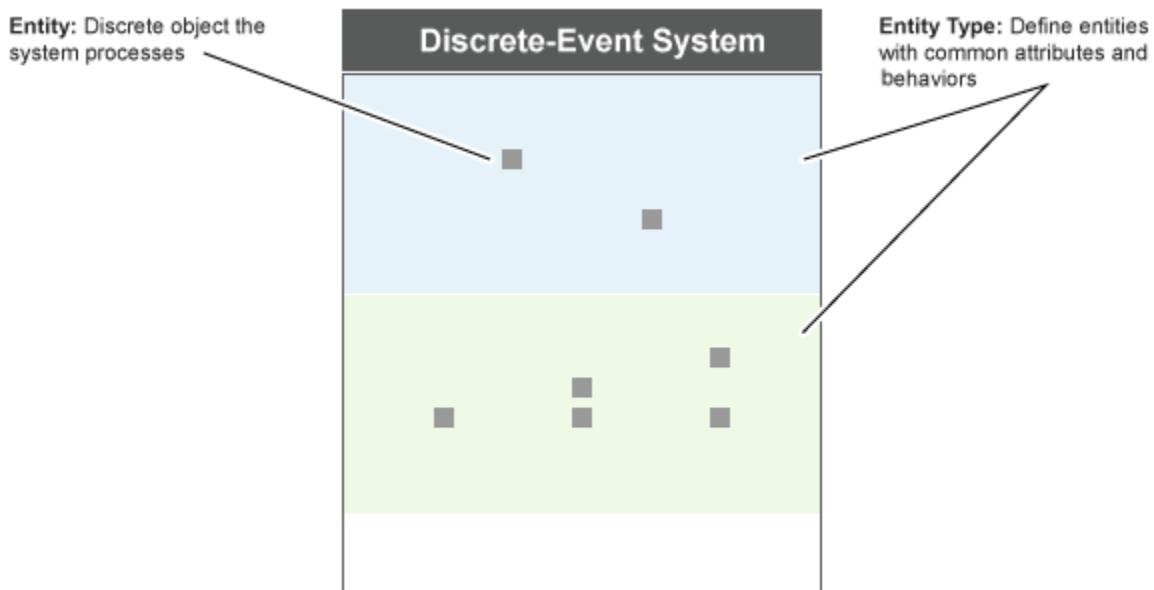

Consider these guidelines when defining custom entity types using the `getEntityTypesImpl` method:

- You can specify multiple entity types. Each type must have a unique name.
- An entity storage element, input port, and output port must specify the entity type they work with.
- Specify or resolve common data specifications for an entity type. For example, an input port and an output port with the same entity type must have the same data type.
- When forwarding an entity, the source and destination data specifications must be same in these instances:

- From an input port to a storage element
- Between storage elements
- From a storage element to an output port
- Each entity type can share a common set of event action methods. When naming these methods, to distinguish the entity type use this convention:

entitytypeAction

For example, if there are two entity types, `car` and `truck`, use method names such as:

```
carEntry  
truckEntry
```

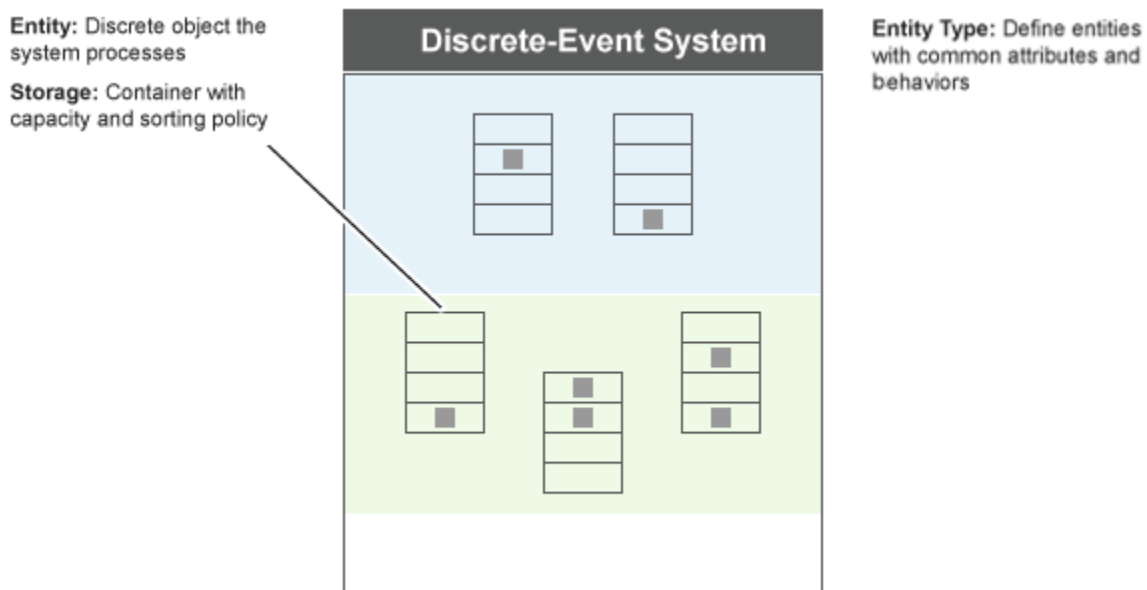

During simulation, an entity always occupies a unit of storage space. Such storage spaces are provided by entity storage elements. A discrete-event System object can contain multiple entity storage elements. Use the `getEntityStorageImpl` method to specify storage elements. A storage space is a container with these properties:

- Entity type — Entity type this storage is handling.

- Capacity — Maximum number of entities that the storage can contain.
- Storage type — Criteria to sort storage entities (FIFO, LIFO, and **priority**).
- Key name — An attribute name used as key name for sorting. This property is applicable only when the storage type is **priority**.
- Sorting direction — Ascending or descending priority queues. This property is applicable only when the storage type is **priority**.

You can access any entity at an arbitrary location of a storage and specify events.

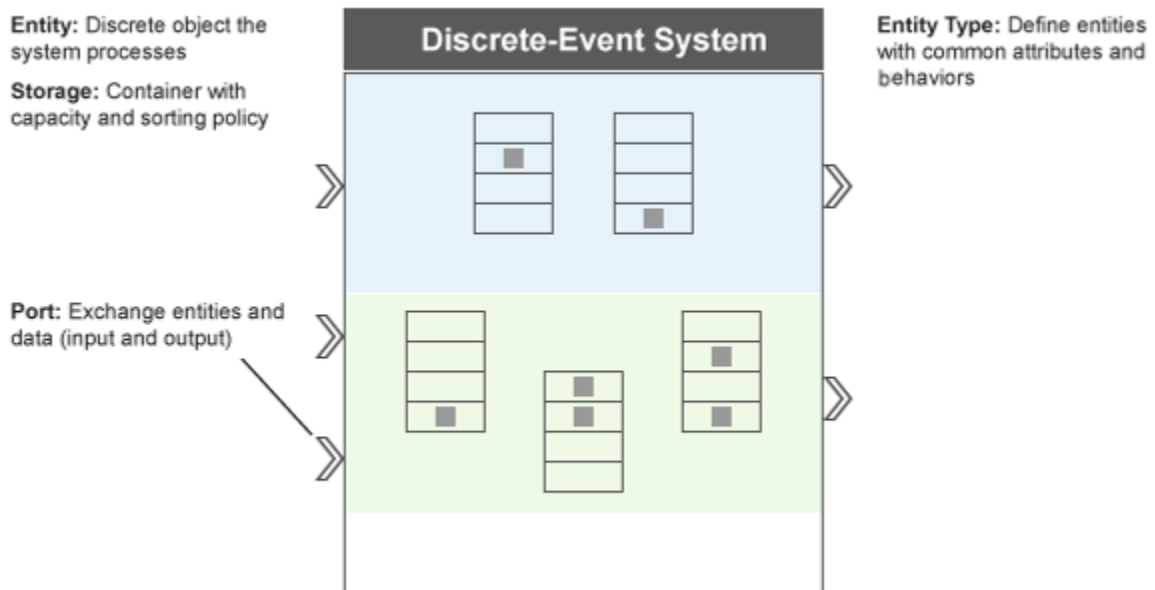

Ports enable a discrete-event System object to exchange entities and data with other blocks or model components. You can specify a variable number of input and output ports using the `getNumInputsImpl` and `getNumOutputsImpl` methods. You can also specify which ports are entity ports and the entity types for these ports. Use the `getEntityPortsImpl` method to specify these port properties.

Events

You can schedule events for a discrete-event System object to execute. Events are associated with user-defined actions. An event action defines a custom behavior by changing state or entity values, and executing the next set of events.

You can use methods and functions to:

- Schedule events
- Define event actions in response to events
- Initialize events
- Cancel events

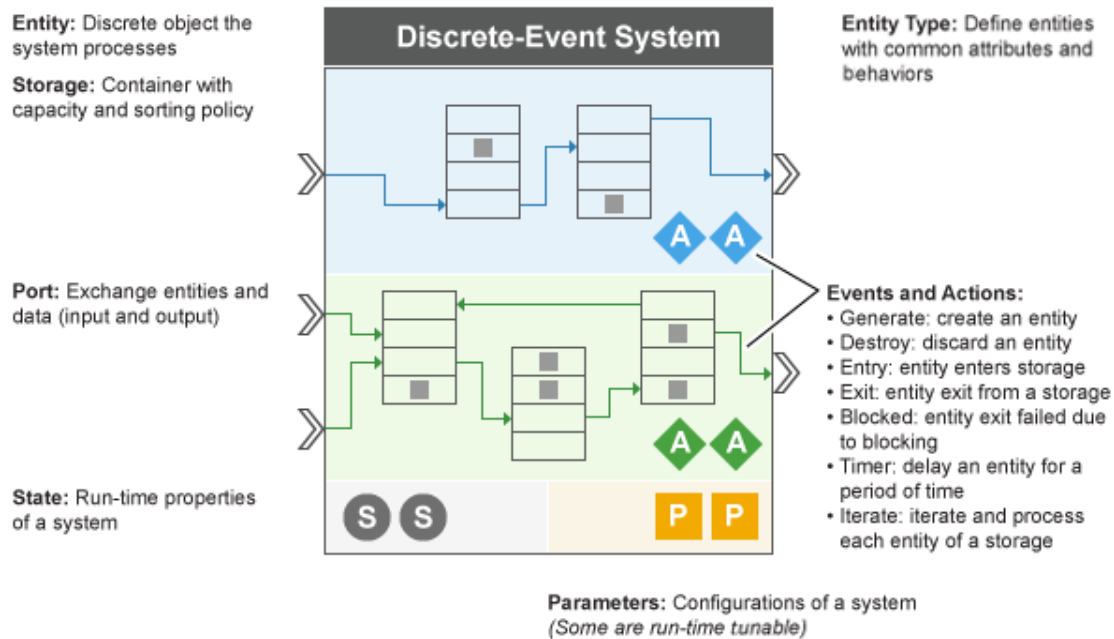

A MATLAB discrete-event System object can have these types of events:

- Storage events — You can schedule these events on a storage element. The actor is a storage element.

- You can generate a new entity inside a storage element.
- You can iterate each entity of a storage element.
- Entity events — You can schedule these events on an entity. Actor is an entity.
 - You can delay an entity.
 - You can forward an entity from its current storage to another storage or output port.
 - You can destroy the existing entity of a storage element.

For more information on using events and event actions, see “Customize Discrete-Event System Behavior Using Events and Event Actions” on page 9-69.

Implement a Discrete-Event System Object with MATLAB Discrete-Event System Block

To implement a custom block by assigning a discrete-event System object, follow these steps.

- 1 Open a new model and add the MATLAB Discrete-Event System block from the SimEvents library.

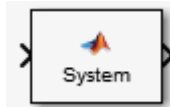

- 2 In the block dialog box, from the **New** list, select **Basic** to create a System object from a template.

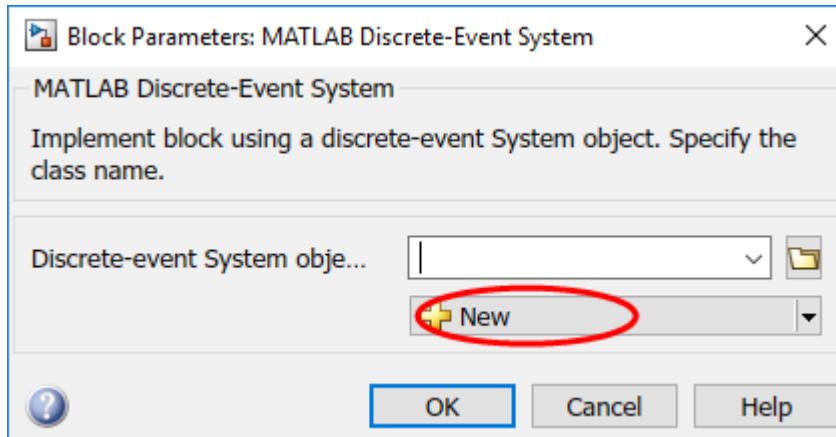

Modify the template as needed and save the System object.

You can also modify the template and define Discrete-Event System objects from the MATLAB Editor using code insertion options. By selecting **Insert Property** or **Insert Method**, the MATLAB Editor adds predefined properties, methods, states, inputs, or outputs to your System object. Use these tools to create and modify System objects faster, and to increase accuracy by reducing typing errors.

- 3 If the System object exists, in the block dialog box, enter its name for the **Discrete-event System object name** parameter. Click the list arrow to see the available discrete-event System objects in the current folder.

The MATLAB Discrete-Event System block icon and port labels update to the icons and labels of the corresponding System object. Suppose that you select a System object named `myServer` in your current folder and generate a custom entity server block that serves entities and outputs each entity through the output port. Then, the block updates as shown in the model.

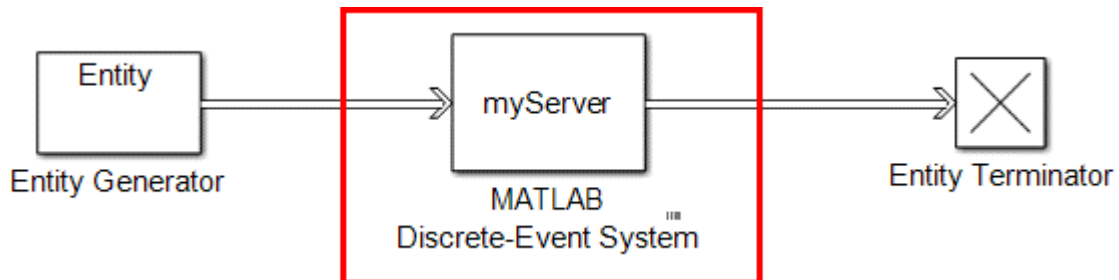

Many different MATLAB System object functions allow you to capture the properties and implement custom behaviors. The provided template is simplified, but you can add complexity by editing event actions, introducing actions, and modifying parameters. The object-oriented programming features of MATLAB System object enable you to scale your model, and interface it with the graphical programming features of SimEvents.

These topics walk you through a complete workflow for creating custom blocks with distinct functionalities.

- 1 “Delay Entities with a Custom Entity Storage Block” on page 9-11
- 2 “Create a Custom Entity Storage Block with Iteration Event” on page 9-17
- 3 “Custom Entity Storage Block with Multiple Timer Events” on page 9-23
- 4 “Custom Entity Generator Block with Signal Input” on page 9-31
- 5 “Build a Custom Block with Multiple Storages” on page 9-39
- 6 “Create a Custom Resource Acquirer Block” on page 9-49

For other examples of MATLAB Discrete-Event System block and discrete-event System objects, type SimEvents Examples in the SimEvents Help browser.

To use provided custom blocks, in the SimEvents library, double-click the Design Patterns block. The **MATLAB Discrete-Event System** category contains these design patterns:

Example	Application
Custom Generator	Implement a more complicated entity generator.
Custom Server	Use a custom server.
Selection Queue	Select a specific entity to output from a queue.

For more information, see “SimEvents Common Design Patterns”.

See Also

`matlab.DiscreteEventSystem` | `matlab.System`

More About

- “Delay Entities with a Custom Entity Storage Block” on page 9-11
- “Integrate System Objects Using MATLAB System Block” (Simulink)

- “Create a Discrete-Event System Object” on page 9-58
- “Customize Discrete-Event System Behavior Using Events and Event Actions” on page 9-69

Delay Entities with a Custom Entity Storage Block

This example shows how to use discrete-event System object methods to create a custom entity storage block that has one input port, one output port, and one storage element. The discrete-event System object is the instantiation of the `matlab.DiscreteEventSystem` class, which allows you to use the implementation and service methods provided by this class. Then, you use the MATLAB Discrete-Event System block to integrate the System object into a SimEvents model.

The custom MATLAB Discrete-Event System block accepts an entity from its input port and forwards it to its output port with a specified delay. The figure visualizes the block using the discrete-event system framework.

To open the model and to observe the behavior of the custom block, see `CustomEntityStorageBlockExample`.

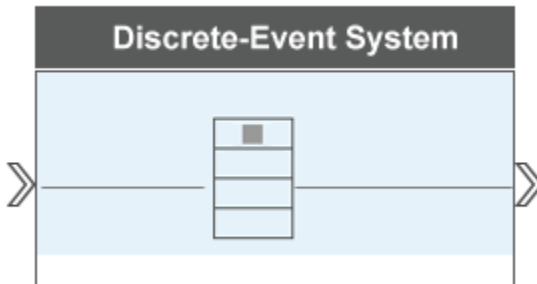

Create the Discrete-Event System Object

- 1 Create a new script and inherit the `matlab.DiscreteEventSystem` class.

```
classdef CustomEntityStorageBlock < matlab.DiscreteEventSystem
```

- 2 Add a custom description to the block.

```
% A custom entity storage block with one input, one output, and one storage.
```

- 3 Declare two nontunable parameters `Capacity` and `Delay` to represent the storage capacity and the entity departure delay from the storage.

```
% Nontunable properties
properties (Nontunable)
    % Capacity
    Capacity = 1;
```

```
% Delay
    Delay = 4;
end
```

The parameters capture the properties of the block.

- Tunable parameters can be tuned during run time.
- Non-tunable parameters cannot be tuned during run time.

4 Specify these methods and set access to protected.

```
methods (Access = protected)

% Specify the number of input ports.
function num = getNumInputsImpl(~)
    num = 1;
end
% Specify the number of output ports.
function num = getNumOutputsImpl(~)
    num = 1;
end
% Specify a new entity type Car.
function entityTypes = getEntityTypesImpl(obj)
    entityTypes = obj.entityType('Car');
end
% Specify Car as the entity type that is used in
% input and output ports.
function [inputTypes,outputTypes] = getEntityPortsImpl(obj)
    inputTypes = {'Car'};
    outputTypes = {'Car'};
end
% Specify the storage type, capacity, and connection to
% the input and output ports.
function [storageSpecs, I, O] = getEntityStorageImpl(obj)
    storageSpecs = obj.queueFIFO('Car', obj.Capacity);
    % First element of I indicates the entity storage index 1 that is
    % connected to input 1.
    I = 1;
    % First element of O indicates the entity storage index 1 that is
    % connected to output 1.
    O = 1;
end
end
```

Only one storage sorts cars in a first-in-first-out (FIFO) manner. The Capacity parameter of the object defines the server capacity.

The method `getEntityStorageImpl()` also specifies the connections between the ports and the storage, I and O.

- The return value I is a vector of elements $i = 1, \dots, n$ where its length n is equal to the number of input ports.

In this example, n is 1 because only one input port is declared.

- The i^{th} element indicates the entity storage index that the i^{th} input port connects to.

In this example, input port 1 is connected to storage 1.

- If an input port is a signal port, the corresponding element is 0.

Similarly the return value 0 is used to define the connections between the storage and the output port.

- 5 Specify an eventForward event to forward an entity of type Car to the output when it enters the storage.

```
function [entity,event] = CarEntry(obj,storage,entity,source)
    % Specify event actions when entity enters storage.
    event = obj.eventForward('output', 1, obj.Delay);
end
```

A Car entry to the storage invokes an event action and the event `obj.eventForward` forwards Car to the output with index 1 with a delay specified by `obj.Delay`.

You can use the input arguments of this method to create custom behavior. The argument `obj` is the discrete-event System object inherited by the method. The argument `storage` is the index of the storage element that the entity enters. The argument `entity` is the entity that enters the storage and it has two fields, `entity.sys` and `entity.data`. The argument `source` is the source location of the entity that enters the storage.

Note You cannot manipulate entity data within an exit action.

- 6 Name your discrete-event System object `CustomEntityStorageBlock` and save it as `CustomEntityStorageBlock.m`.

The custom block represents a simplified gas station that can serve one car at a time. A car arrives at the gas station and is serviced for 4 minutes before departing the station.

See the Code to Generate Custom Entity Storage Block

```
classdef CustomEntityStorageBlock < matlab.DiscreteEventSystem
    % A custom entity storage block with one input, one output, and one storage.

    % Nontunable properties
    properties (Nontunable)
        % Capacity
        Capacity = 1;
```

```

% Delay
    Delay = 4;
end

methods (Access = protected)

    function num = getNumInputsImpl(~)
        num = 1;
    end

    function num = getNumOutputsImpl(~)
        num = 1;
    end

    function entityTypes = getEntityTypesImpl(obj)
        entityTypes = obj.entityType('Car');
    end

    function [inputTypes,outputTypes] = getEntityPortsImpl(obj)
        inputTypes = {'Car'};
        outputTypes = {'Car'};
    end

    function [storageSpecs, I, O] = getEntityStorageImpl(obj)
        storageSpecs = obj.queueFIFO('Car', obj.Capacity);
        I = 1;
        O = 1;
    end

end

methods

    function [entity,event] = CarEntry(obj,storage,entity,source)
        % Specify event actions when entity enters storage.
        event = obj.eventForward('output', 1, obj.Delay);
    end

end

end

```

Implementing the Custom Entity Storage Block

- 1 Create a model using an Entity Generator block, MATLAB Discrete-Event System block, and an Entity Terminator block.

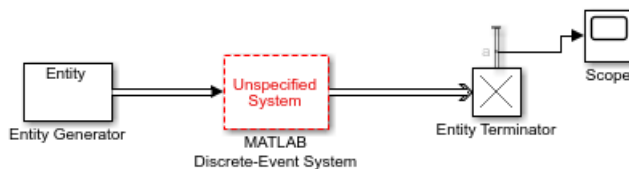

- Open the MATLAB Discrete-Event System block, and set the **Discrete-event System object name** to CustomEntityStorageBlock.

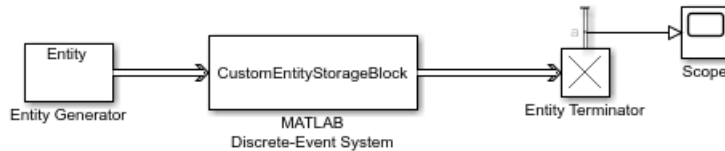

- Double-click the MATLAB Discrete-Event System block to observe its capacity and delay.

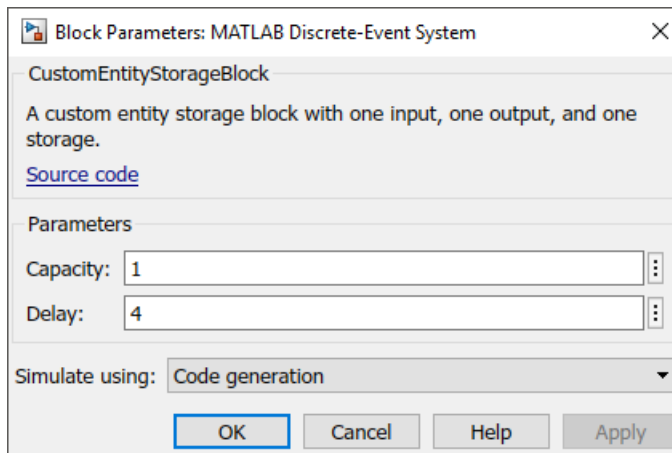

- Output the **Number of entities arrived**, a statistic from the Entity Terminator block and connect it to a scope
- Increase the simulation time to 20 and run the simulation. Observe the entities arriving at the Entity Terminator block with a delay of 4.

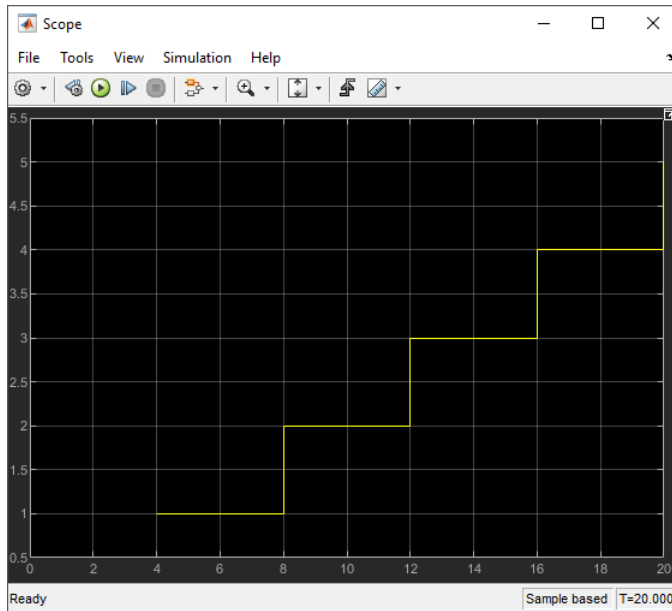

See Also

[entry](#) | [getEntityPortsImpl](#) | [getEntityStorageImpl](#) | [getEntityTypesImpl](#) | [matlab.DiscreteEventSystem](#) | [matlab.System](#)

More About

- “Integrate System Objects Using MATLAB System Block” (Simulink)
- “Create a Discrete-Event System Object” on page 9-58
- “Generate Code for MATLAB Discrete-Event System Blocks” on page 9-65
- “Call Simulink Function from a MATLAB Discrete-Event System Block” on page 9-75

Create a Custom Entity Storage Block with Iteration Event

A discrete-event System object can contain multiple event types for manipulating entities, acting on the storages, and resource management. When an event is due for execution, a discrete-event system can respond to that event by invoking event actions. The goal of this example is to show how to work with events and event actions when creating a custom block. To see the list of provided event and event actions, see “Customize Discrete-Event System Behavior Using Events and Event Actions” on page 9-69.

To open the model and to observe the behavior of the custom block, see `CustomEntityStorageBlockWithIterationEventExample`.

Create the Discrete-Event System Object

In this example, a custom block allows entities to enter its storage element through its input port. The storage element sorts the entities based on their `Diameter` attribute in ascending order. Every entity entry to the block’s storage invokes an iteration event to display the diameter and the position of each entity in the storage.

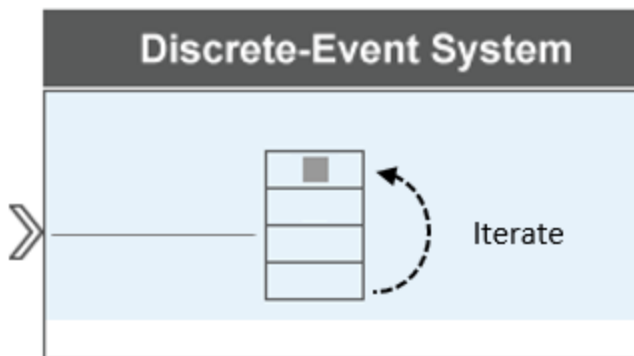

The storage element allows you to define its capacity to store and sort entities during which any entity can be accessed and manipulated. In this example, the storage with capacity 5 is used to store and sort car wheels based on their `Diameter` attribute in an ascending order. When a new wheel enters the storage, an iteration event `eventIterate` is invoked, which triggers an iteration event action `iterate` to display wheel positions in the storage and their diameter.

See the Code to Generate the Custom Storage Block with Iteration Event

```

classdef CustomEntityStorageBlockIteration < matlab.DiscreteEventSystem

    % A custom entity storage block with one input port and one storage element.

    % Nontunable properties
    properties (Nontunable)
        % Capacity
        Capacity = 5;
    end
    % Create the storage element with one input and one storage.
    methods (Access=protected)

        function num = getNumInputsImpl(obj)
            num = 1;
        end

        function num = getNumOutputsImpl(obj)
            num = 0;
        end

        function entityTypes = getEntityTypesImpl(obj)
            entityType = obj.entityType('Wheel');
            entityTypes = entityType;
        end

        function [inputTypes,outputTypes] = getEntityPortsImpl(obj)
            inputTypes = {'Wheel'};
            outputTypes={};
        end

        function [storageSpecs, I, O] = getEntityStorageImpl(obj)
            storageSpecs = obj.queuePriority('Wheel',obj.Capacity, 'Diameter','ascending');
            I = 1;
            O = [];
        end

    end
end
% Entity entry event action
methods

    function [entity, event] = WheelEntry(obj,storage,entity, source)
        % Entity entry invokes an iterate event.
        event = obj.eventIterate(1, '');
    end

    % The itarate event action
    function [entity,event,next] = WheelIterate(obj,storage,entity,tag,cur)
        % Display wheel id, position in the storage, and diameter.
        coder.extrinsic('fprintf');
        fprintf('Wheel id %d, Current position %d, Diameter %d\n', ...
            entity.sys.id, cur.position, entity.data.Diameter);
        if cur.size == cur.position
            fprintf('End of Iteration \n')
        end
        next = true;
        event=[];
    end
end

```

```
end
```

```
end
```

Define Custom Block Behavior

- 1 Define a storage with capacity `obj.Capacity`, which sorts wheels based in their priority value. The priority values are acquired from the `Diameter` attributes of the entities and are sorted in ascending order.

```
function [storageSpecs, I, 0] = getEntityStorageImpl(obj)
    storageSpecs = obj.queuePriority('Wheel',obj.Capacity, 'Diameter','ascending');
    I = 1;
    0 = [];
end
```

- 2 A wheel's entry into the storage invokes an iterate event.

```
function [entity, event] = WheelEntry(obj,storage,entity, source)
    % Entity entry invokes an iterate event.
    event = obj.eventIterate(1, '');
end
```

Input argument `1` is the storage index for the iterate event, and `''` is the tag name.

- 3 The iterate event invokes an iterate event action.

```
% The itarate event action
function [entity,event,next] = WheelIterate(obj,storage,entity,tag,cur)
    % Display wheel id, position in the storage, and diameter.
    coder.extrinsic('fprintf');
    fprintf('Wheel id %d, Current position %d, Diameter %d\n', ...
        entity.sys.id, cur.position, entity.data.Diameter);
    if cur.size == cur.position
        fprintf('End of Iteration \n')
    end
    next = true;
    event=[];
end
```

In the code, `coder.extrinsic('fprintf')` declares the function `fprintf()` as extrinsic function for code generation. For each iteration, the code displays the new wheel ID, current position, and diameter, which is used as sorting attribute.

Implement Custom Block

- 1 Save the `.m` file as `CustomEntityStorageBlockIteration`. Link the System object to a SimEvents model by using a MATLAB Discrete-Event System block. For more information about linking, see “Create Custom Blocks Using MATLAB Discrete-Event System Block” on page 9-2.

- 2 Create a SimEvents model including the MATLAB Discrete-Event System block, and an Entity Generator block.

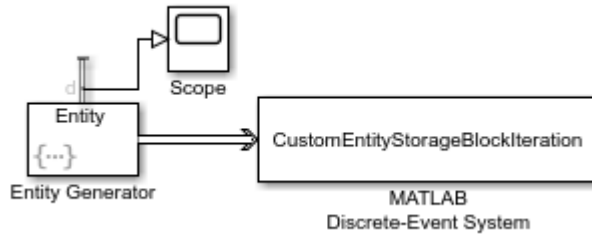

- 3 In the Entity Generator block:
 - a In the **Entity type** tab, set the **Attribute Name** as Diameter.

The attribute `Diameter` is used to sort entities in the MATLAB Discrete-Event System block.
 - b In the **Event actions** tab, in the **Generate action** field, add this code to randomize the size of the incoming entities.

```
entity.Diameter = randi([1 10]);
```
 - c In the **Statistics** tab, output the **Number of entities departed, d** statistic and connect to a scope.
- 4 Connect the blocks as shown and simulate the model.
 - a Observe that the Entity Generator block generates 5 entities since the capacity of the storage block is 5.

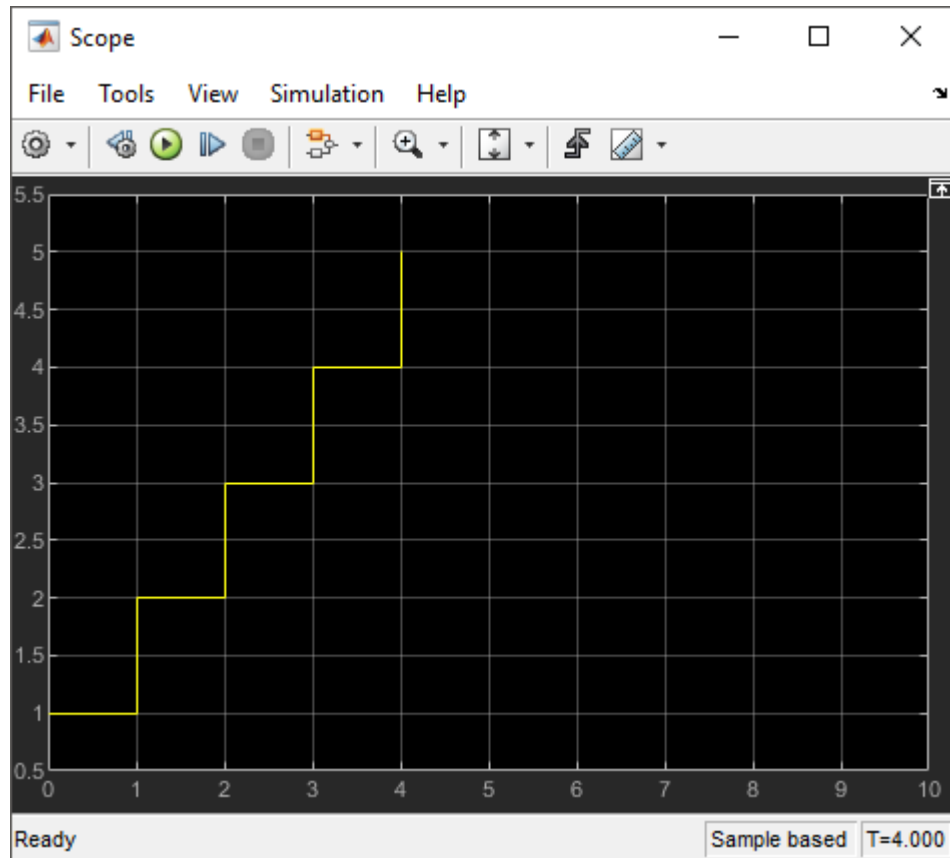

- b** The Diagnostic Viewer displays the iteration event for each wheel entry to the storage. Each iteration displays ID, position, and diameter of the wheels. Observe how each wheel entry changes the order of the stored wheels. In the last iteration, 5 entities in the storage are sorted in ascending order.

```
Wheel id 1, Current position 1 and Diameter 9
End of Iteration
Wheel id 1, Current position 1 and Diameter 9
Wheel id 2, Current position 2 and Diameter 10
End of Iteration
Wheel id 3, Current position 1 and Diameter 2
Wheel id 1, Current position 2 and Diameter 9
Wheel id 2, Current position 3 and Diameter 10
End of Iteration
Wheel id 3, Current position 1 and Diameter 2
Wheel id 1, Current position 2 and Diameter 9
Wheel id 2, Current position 3 and Diameter 10
Wheel id 4, Current position 4 and Diameter 10
End of Iteration
Wheel id 3, Current position 1 and Diameter 2
Wheel id 5, Current position 2 and Diameter 7
Wheel id 1, Current position 3 and Diameter 9
Wheel id 2, Current position 4 and Diameter 10
Wheel id 4, Current position 5 and Diameter 10
End of Iteration
```

See Also

[entry](#) | [eventIterate](#) | [getEntityPortsImpl](#) | [getEntityStorageImpl](#) | [getEntityTypesImpl](#) | [iterate](#) | [matlab.DiscreteEventSystem](#) | [matlab.System](#)

More About

- “Integrate System Objects Using MATLAB System Block” (Simulink)
- “Create a Discrete-Event System Object” on page 9-58
- “Generate Code for MATLAB Discrete-Event System Blocks” on page 9-65
- “Call Simulink Function from a MATLAB Discrete-Event System Block” on page 9-75

Custom Entity Storage Block with Multiple Timer Events

A discrete-event system allows the implementation of distinct event types for manipulating entities and storages. Sometimes, the desired behavior involves more than one event acting on the same storage or entity. This example shows how to handle multiple events acting on the same target in a discrete-event system framework. In this example, a custom entity storage block is generated to implement the `tag`, which is one of the identifiers, when multiple timer events are acting on the same entity. To see the list of event identifiers, see “Customize Discrete-Event System Behavior Using Events and Event Actions” on page 9-69.

To open the model and observe the behavior of the custom block, see `CustomEntityStorageBlockWithTwoTimerEventsExample`.

Create the Discrete-Event System Object with Multiple Timer Events

Suppose that the discrete-event System object is used to represent a facility that processes metal parts using an oven. The processing time varies based on the detected metal. For safety, the parts have a maximum allowed processing time.

- If the oven processing time is less than the allowed maximum time, the parts are processed and depart the oven and the facility.
- If there is an error in detected metal, the service time exceeds the maximum allowed processing time, the process stops and the parts are taken out of the oven to be rerouted for further processing.

To represent this behavior, this example uses a custom entity storage block with one input, two outputs, and a storage element. An entity of type `Part` with `TimeOut` attribute enters the storage of the custom block to be processed. `TimeOut` determines the maximum allowed processing time of the parts. When a part enters the storage, two timer events are activated. One timer tracks the processing time of the part in the oven. When this timer expires, the entity is forwarded to output 1. Another timer acts as a fail-safe and tracks if the maximum allowed processing time is exceeded or not. When this timer expires, the process is terminated and the entity is forwarded to the output 2.

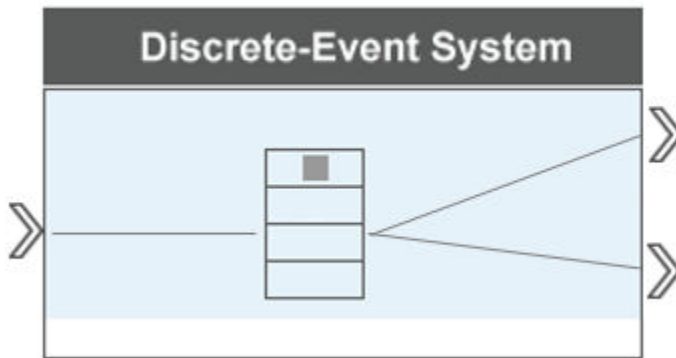

This example that generates the custom block and uniquely identifies these two timer events targeting on the same entity using custom tags.

See the Code to Generate the Custom Storage Block with Timer Events

```

classdef CustomEntityStorageBlockTimer < matlab.DiscreteEventSystem

    % A custom entity storage block with one input port, two output ports, and one storage.

    % Nontunable properties
    properties (Nontunable)
    % Capacity
        Capacity = 1;
    end

    methods (Access=protected)

        function num = getNumInputsImpl(~)
            num = 1;
        end

        function num = getNumOutputsImpl(~)
            num = 2;
        end

        function entityType = getEntityTypeImpl(obj)
            entityType = obj.entityType('Part');
        end

        function [inputTypes,outputTypes] = getEntityPortsImpl(obj)
            inputTypes = {'Part'};
            outputTypes = {'Part' 'Part'};
        end

        function [storageSpecs, I, O] = getEntityStorageImpl(obj)
            storageSpecs = obj.queueFIFO('Part', obj.Capacity);
            I = 1;
            O = [1 1];
        end
    end
end

```



```

end

methods

function [entity,event] = PartEntry(obj,storage,entity,source)
    % Specify event actions when entity enters storage.
    ProcessingTime=randi([1 15]);
    event1 = obj.eventTimer('TimeOut', entity.data.TimeOut);
    event2 = obj.eventTimer('ProcessComplete', ProcessingTime);
    event = [event1 event2];
end

function [entity, event] = timer(obj,storage,entity,tag)
    % Specify event actions for when scheduled timer completes.
    event = obj.initEventArray;
    switch tag
        case 'ProcessComplete'
            event = obj.eventForward('output', 1, 0);
        case 'TimeOut'
            event = obj.eventForward('output', 2, 0);
    end
end

end

end

end

```

Custom Block Behavior

- 1 Generate a custom block with one input, two outputs, and a storage element. For more information about creating a basic storage element, see “Implement a Discrete-Event System Object with MATLAB Discrete-Event System Block” on page 9-7.

```

function num = getNumInputsImpl(~)
    num = 1;
end

function num = getNumOutputsImpl(~)
    num = 2;
end

function entityTypes = getEntityTypesImpl(obj)
    entityTypes = obj.entityType('Part');
end

function [inputTypes,outputTypes] = getEntityPortsImpl(obj)
    inputTypes = {'Part'};
    outputTypes = {'Part' 'Part'};
end

function [storageSpecs, I, O] = getEntityStorageImpl(obj)
    storageSpecs = obj.queueFIFO('entity1', obj.Capacity);
    I = 1;
    O = [1 1];
end

```

- Invoke two timers with tags 'TimeOut' and 'ProcessComplete' when an entity enters the storage.

```
function [entity,event] = PartEntry(obj,storage,entity,source)
% Specify event actions when entity enters storage.
ProcessingTime = randi([1 15]);
% The TimeOut attribute specifies the expiration time of the timer with tag TimeOut
event1 = obj.eventTimer('TimeOut', entity.data.TimeOut);
% The expiration time of the timer ProcessComplete is a random integer between
% 1 and 15.
event2 = obj.eventTimer('ProcessComplete', ProcessingTime);
event = [event1 event2];
end
```

- The timer that expires the first determines the entity forward behavior.

```
function [entity, event] = timer(obj,storage,entity,tag)
% Specify event actions for when scheduled timer completes.
event = obj.initEventArray;
switch tag
case 'ProcessComplete'
% If ProcessComplete expires first, entities are forwarded to output 1.
event = obj.eventForward('output', 1, 0);
case 'TimeOut'
% If TimeOut expires first, entities are forwarded to output 2.
event = obj.eventForward('output', 2, 0);
end
end
```

Implement Custom Block

- Save the .m file as CustomEntityStorageBlockTimer. Link the System object to a SimEvents model by using a MATLAB Discrete-Event System block. For more information about linking, see “Create Custom Blocks Using MATLAB Discrete-Event System Block” on page 9-2.
- Create a SimEvents model including the MATLAB Discrete-Event System block, an Entity Generator block, two Entity Terminator blocks. Connect the blocks as shown in the model.

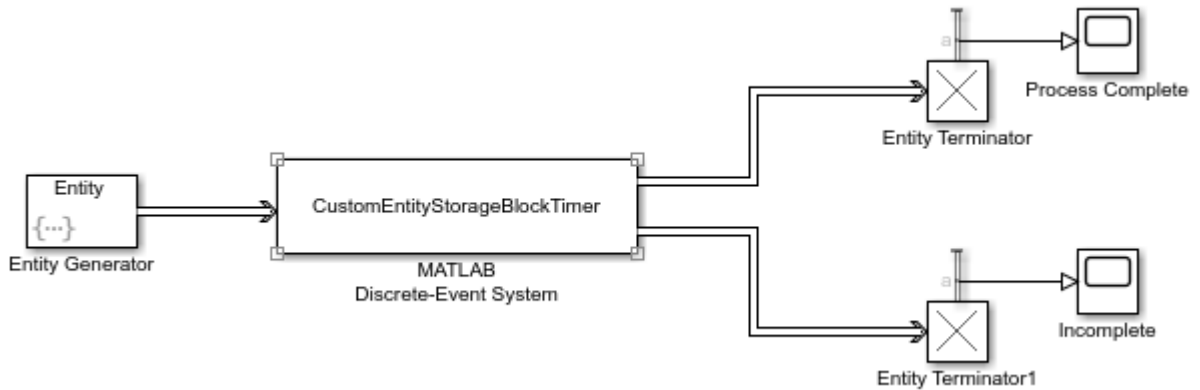

- 3 In the Entity Generator block:
 - a In the **Entity type** tab, set the **Attribute Name** as TimeOut.
 - b In the **Event actions** tab, in the **Generate action** field:

```
entity.TimeOut = 10;
```
- 4 In the Entity Terminator and Entity Terminator1 blocks, output the **Number of entities arrived**, **a** statistic and connect them to scopes.
- 5 Increase simulation time to 100 and simulate the model. Observe that entities are forwarded to the corresponding output based on the corresponding timer expiration.

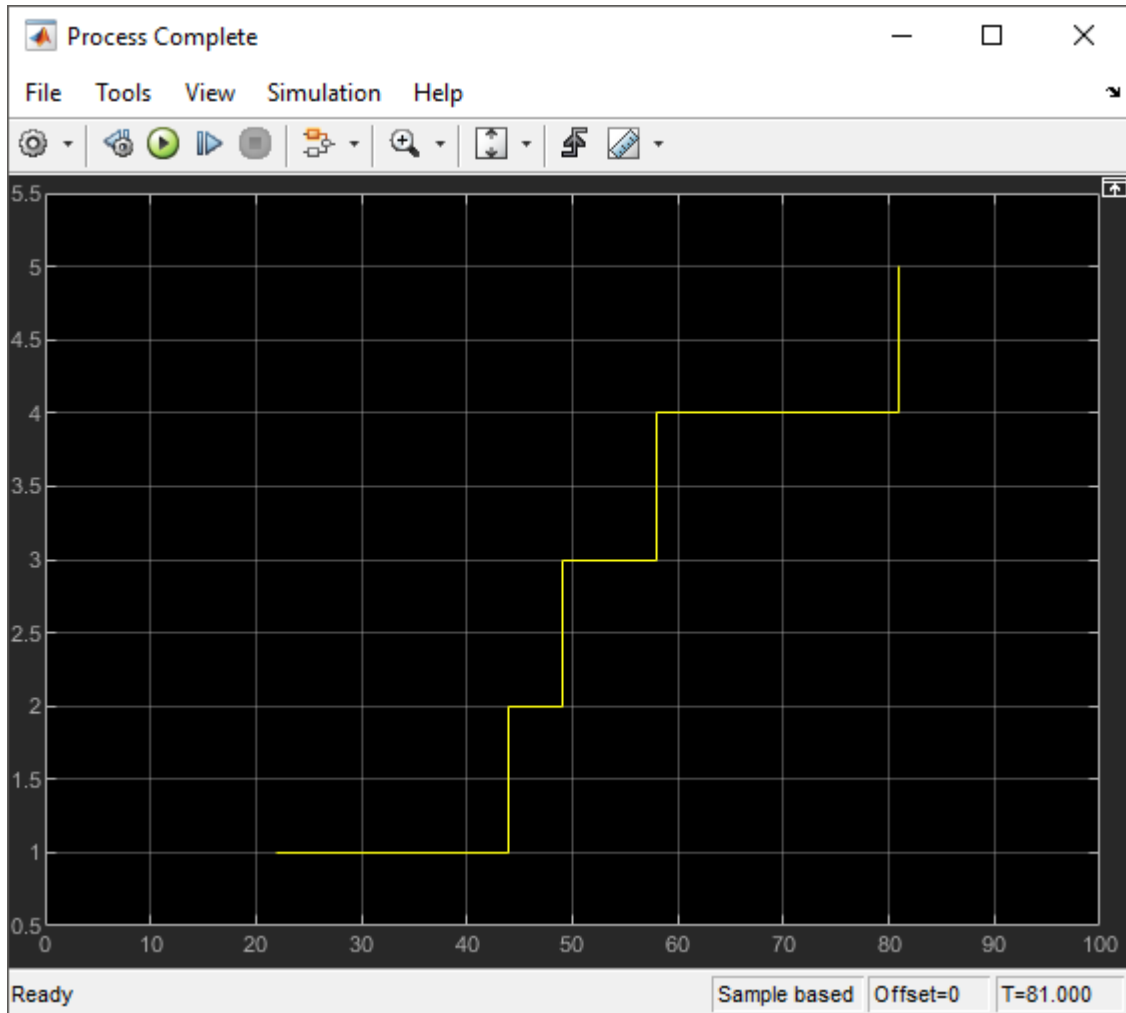

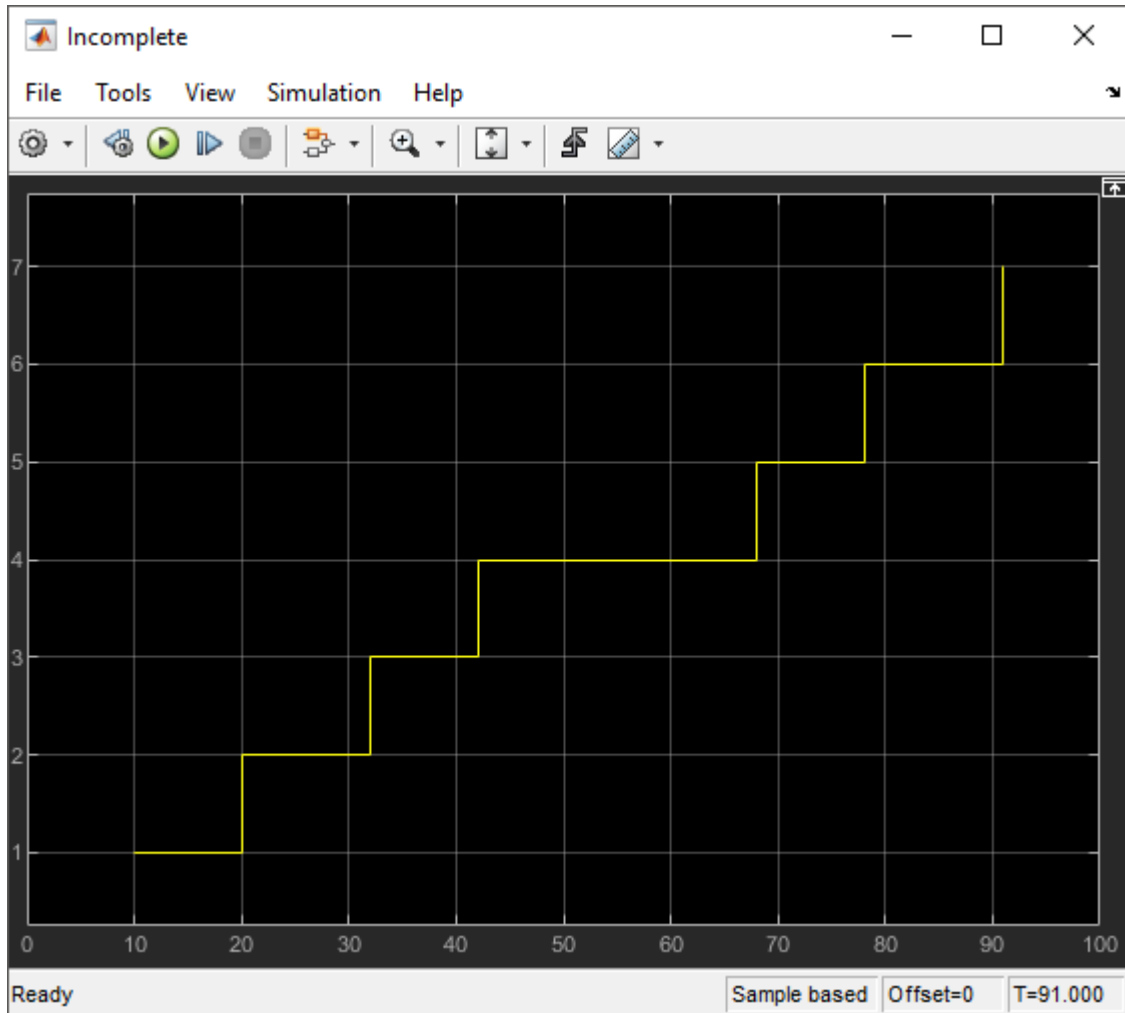

See Also

[entry](#) | [eventTimer](#) | [getEntityPortsImpl](#) | [getEntityStorageImpl](#) |
[getEntityTypesImpl](#) | [matlab.DiscreteEventSystem](#) | [matlab.System](#) | [timer](#)

More About

- “Integrate System Objects Using MATLAB System Block” (Simulink)
- “Create a Discrete-Event System Object” on page 9-58
- “Generate Code for MATLAB Discrete-Event System Blocks” on page 9-65
- “Call Simulink Function from a MATLAB Discrete-Event System Block” on page 9-75

Custom Entity Generator Block with Signal Input

This example shows how to create a custom source block that generates entities and to manage discrete states when implementing the discrete-event System object methods.

Suppose that you manage a facility that produces raw materials with a fixed deterministic rate. The materials contain a 12-digit bar code for stock management and priority values for order prioritization. To represent this behavior, this example shows how to generate a custom entity storage block is generated with one signal input port, one entity output port, and one storage element. The block generates entities with distinct priority values. The entities carry data and depart the block from its output port. The entity priority values are acquired from values of the incoming signal.

To open the model and to observe the behavior of the custom block, see `CustomEntityGeneratorBlockExample`.

Create the Discrete-Event System Object

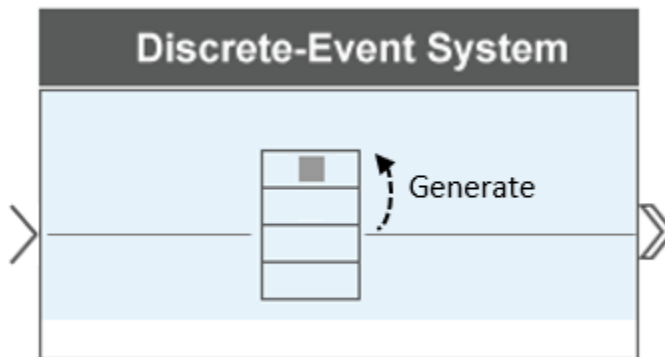

The block is defined as a custom entity generator block that generates entities with specified intergeneration periods. The generated entities carry data, and their priority values are determined by the values of the input signal.

See the Code to Create the Custom Entity Generator Block

```
classdef CustomEntityStorageBlockGeneration < matlab.DiscreteEventSystem...
    & matlab.system.mixin.Propagates
    % A custom entity generator block.
    % Nontunable properties
```

```

properties (Nontunable)
    % Generation period
    period = 1;
end

properties(DiscreteState)
    % Entity priority
    priority;
    % Entity value
    value;
end

% Discrete-event algorithms
methods
    function events = setupEvents(obj)
        % Set up entity generation events at simulation start.
        events = obj.eventGenerate(1,'mygen',obj.period,obj.priority);
    end

    function [entity,events] = generate(obj,storage,entity,tag,in1)
        % Specify event actions when entity is generated in storage.
        entity.data = obj.value;
        obj.priority = in1;
        events = [obj.eventForward('output',1,0) ...
                obj.eventGenerate(1,'mygen',obj.period,obj.priority)];
    end
end

methods(Access = protected)

    function entityTypes = getEntityTypesImpl(obj)
        entityTypes = obj.entityType('Material');
    end

    function [inputTypes,outputTypes] = getEntityPortsImpl(obj)
        % Specify entity input and output ports. Return entity types at
        % a port as strings in a cell array. Use empty string to
        % indicate a data port.
        inputTypes = {' '};
        outputTypes = {'Material'};
    end

    function resetImpl(obj)
        % Initialize / reset discrete-state properties.
        obj.priority = 10;
        obj.value = 1:12;
    end

    function [storageSpecs, I, O] = getEntityStorageImpl(obj)
        storageSpecs = obj.queueFIFO('Material', 1);
        I = 0;
        O = 1;
    end

    function num = getNumInputsImpl(obj)
        % Define total number of inputs for system with optional inputs.
        num = 1;
    end

    function out = getOutputSizeImpl(obj)
        % Return size for output port.
        out = [1 12];
    end
end

```



```

end

function out = getOutputDataTypeImpl(obj)
    % Return data type for output port.
    out = "double";
end

function out = isOutputComplexImpl(obj)
    % Return true for output port with complex data.
    out = false;
end

function [sz,dt,cp] = getDiscreteStateSpecificationImpl(obj,name)
    % Return size, data type, and complexity of discrete-state.
    switch name
        case 'priority'
            sz = [1 1];
        case 'value'
            sz = [1 12];
    end
    dt = "double";
    cp = false;
end

end

end

```

Custom Block Behavior

- 1 Define the time between material generations.

```

% Nontunable properties
properties (Nontunable)
    % Generation period
    period = 1;
end

```

- 2 Initialize the discrete state variables.

```

function resetImpl(obj)
    % Initialize / reset discrete-state properties.
    obj.priority = 10;
    obj.value = 1:12;
end

```

The variable `priority` represents material priority and the `value` represents bar code data carried by the materials.

- 3 Initialize the output for a source block.

```

function out = getOutputSizeImpl(obj)
    % Return size for output port.
    out = [1 12];
end

function out = getOutputDataTypeImpl(obj)
    % Return data type for output port.
    out = "double";
end

```

```

end

function out = isOutputComplexImpl(obj)
    % Return true for output port with complex data.
    out = false;
end

```

- First function declares the output size.
 - Second function declares that output port data type is double.
 - Third function declares `false` for output port because it does not support complex data.
- 4 Declare the size, data, and complexity of the discrete states.

```

function [sz,dt,cp] = getDiscreteStateSpecificationImpl(obj,name)
    % Return size, data type, and complexity of discrete-state.
    switch name
        case 'priority'
            sz = [1 1];
        case 'value'
            sz = [1 12];
    end
    dt = "double";
    cp = false;
end

```

- The discrete state `priority` is scalar. The data type is `double` and takes real values.
 - The discrete state `value` is a 1-by-12 vector. The data type is `double` and takes real values.
- 5 Generate the materials with intergeneration period, priority, and data defined by:
- The parameter `obj.period`, declared as a public parameter that can be changed from the block dialog box.
 - The parameter `obj.priority` values, defined by the signal from the input port.
 - The parameter `obj.value`, a 1-by-12 vector which represents the data carried by entities.

```

function events = setupEvents(obj)
    % Set up entity generation event for storage 1 at simulation start.
    events = obj.eventGenerate(1,'mygen',obj.period,obj.priority);
end

function [entity,events] = generate(obj,storage,entity,tag,in1)
    % Specify event actions when entity is generated in storage.
    entity.data = obj.value;
    % The value from the signal is assigned to the entity priority.
    obj.priority = in1;
    events = [obj.eventForward('output',1,0) ...
             obj.eventGenerate(1,'mygen',obj.period,obj.priority)];
end

```

Implement Custom Block

- 1 Save the .m file as CustomEntityStorageBlockGeneration. Link the System object to a SimEvents model by using a MATLAB Discrete-Event System block. For more information about linking, see “Create Custom Blocks Using MATLAB Discrete-Event System Block” on page 9-2.
- 2 Create a SimEvents model that includes the MATLAB Discrete-Event System block, a Ramp block, and an Entity Terminator block. Connect the blocks as shown in the model.

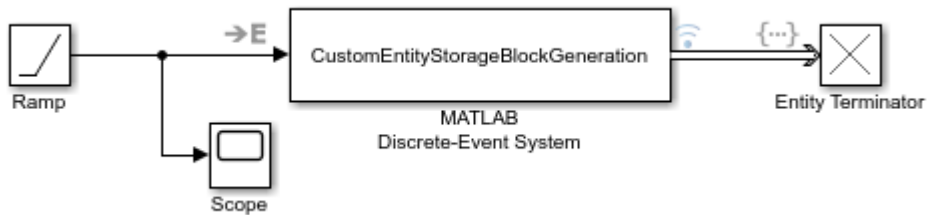

- 3 In the Ramp block, set **Slope** to 5 and **Initial output** to 10.
- 4 Scope the signal between the Ramp block and the MATLAB Discrete-Event System block.
- 5 In the Entity Terminator block, to display the priority values of the entities arriving at the block, in the **Entry action** field enter this code.

```
coder.extrinsic('fprintf');
fprintf('Priority: %d\n', double(entitySys.priority))
```
- 6 Right-click the entity path from the custom Entity Generator to the Entity Terminator and select the **Log Selected Signals**.
- 7 Simulate the model.
 - a Observe the output of the Ramp block. For instance, the output value becomes 15, 20, 25, and 30 for the simulation time 1, 2, 3, and 4, respectively.

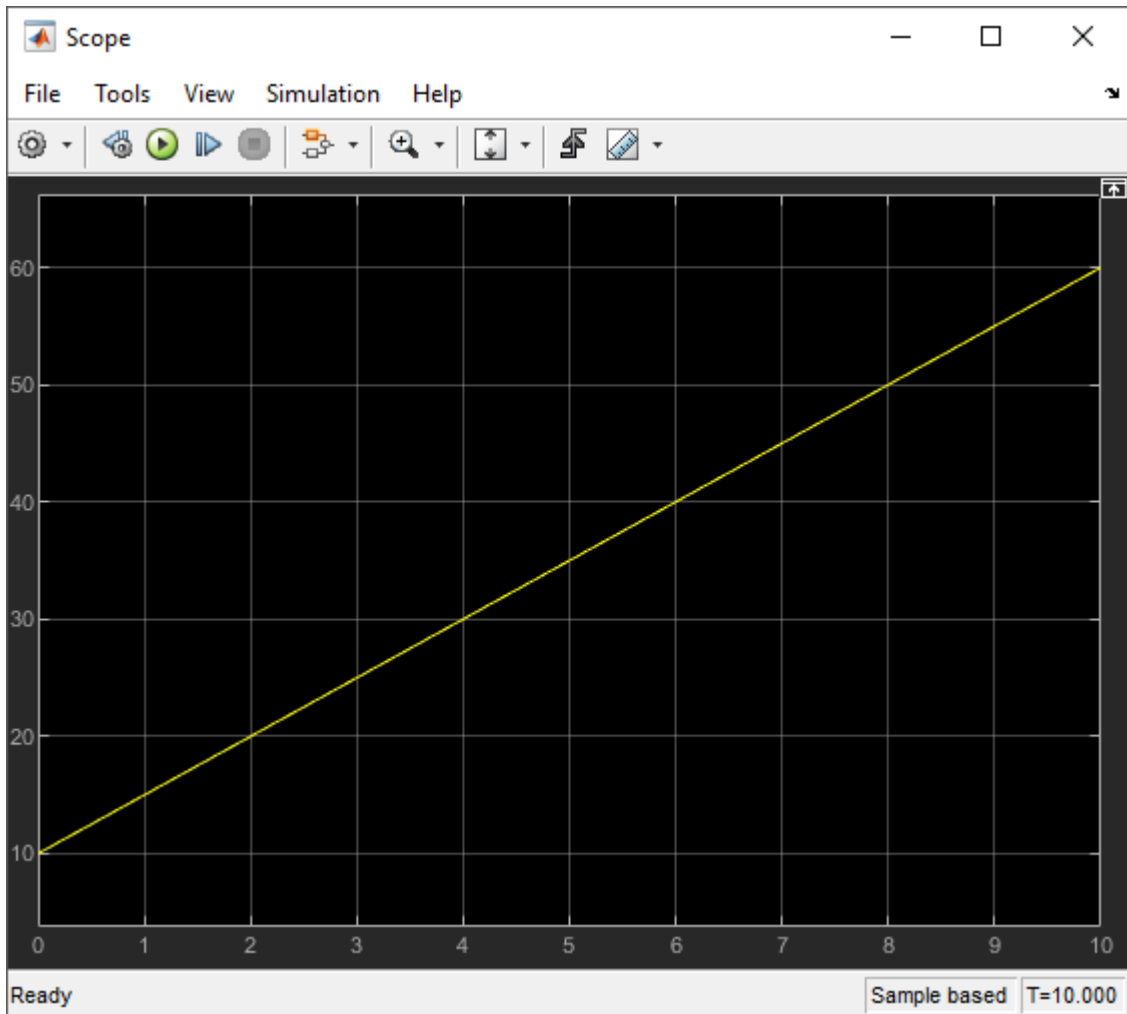

- b** The Simulation Data Inspector shows that entities are forwarded to the Entity Terminator block with data of size 1-by-12.

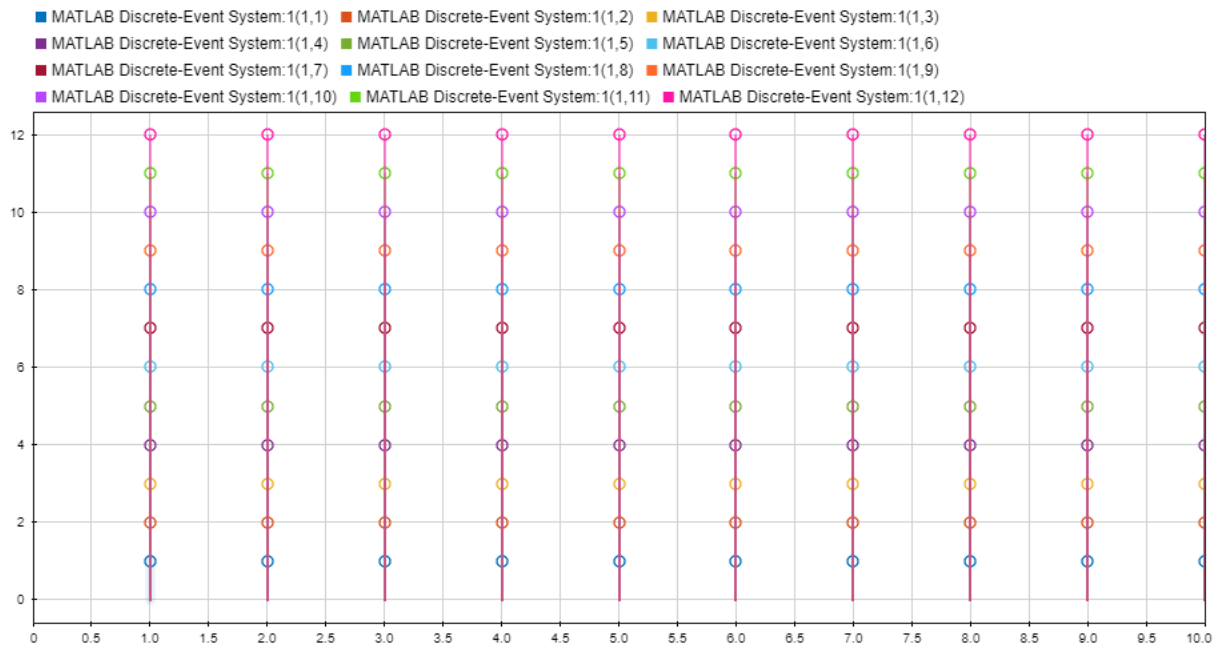

- c The Diagnostic Viewer shows the `entitySys.priority` values. The priority values are acquired from the ramp signal value at entity generation times 1, 2, 3, 4, 5, 6, 7, 8, 9, and 10.

```

Simulation 1
02:13 PM Elapsed: 2 sec
Priority: 10
Priority: 15
Priority: 20
Priority: 25
Priority: 30
Priority: 35
Priority: 40
Priority: 45
Priority: 50
Priority: 55
    
```

See Also

entry | generate | getEntityPortsImpl | getEntityStorageImpl |
matlab.DiscreteEventSystem | matlab.System

More About

- “Integrate System Objects Using MATLAB System Block” (Simulink)
- “Create a Discrete-Event System Object” on page 9-58
- “Generate Code for MATLAB Discrete-Event System Blocks” on page 9-65
- “Call Simulink Function from a MATLAB Discrete-Event System Block” on page 9-75

Build a Custom Block with Multiple Storages

This example shows how to create a custom block with multiple storages and manage storage behavior using discrete-event System object methods.

Suppose that you manage a facility that produces items for customer orders. To prepare for repetitive orders, the facility produces a supply of items before the orders arrive. When a new order arrives, the stocks are checked for availability.

- If the item is found in the storage, it departs the facility to fulfil the order.
- If the item is not found in the storage, a new item is produced and the generated item departs the facility to fulfil the order.

To generate this custom behavior, you manipulate multiple storages through a discrete-event System object, created using the `matlab.DiscreteEventSystem` methods. To observe the behavior of the custom block, see `CustomEntityStorageBlockWithTwoStoragesExample`.

Create the Discrete-Event System Object

Generate a custom entity storage block with two inputs, one output, and two storage elements.

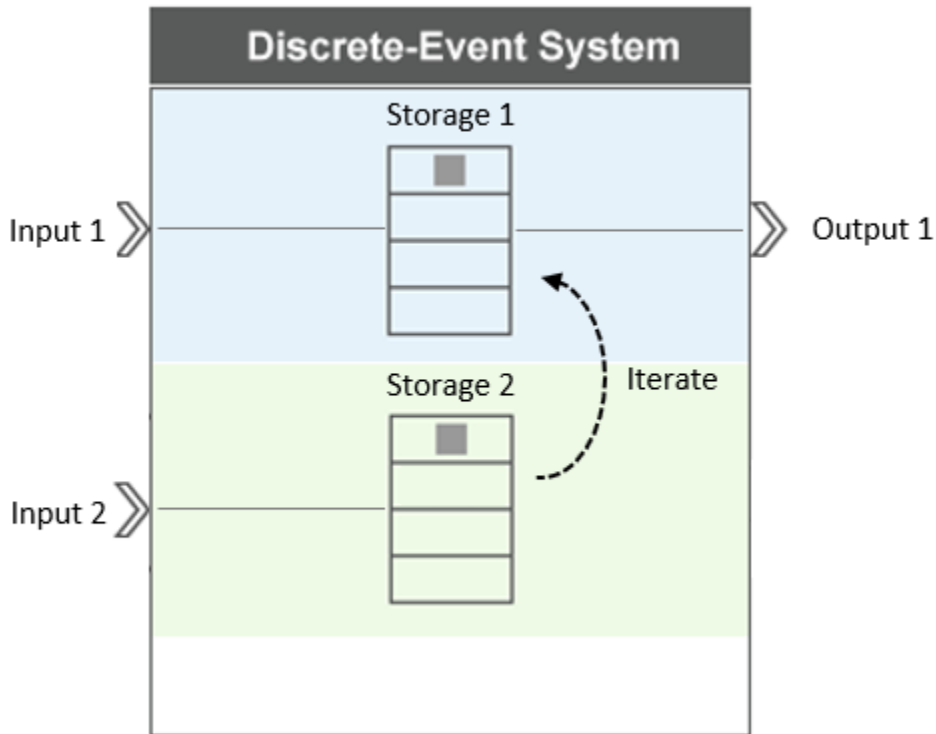

The desired behavior of the custom block is to select and output entities based on a reference entity.

- 1 Input port 1 accepts entities with type `Item` to storage 1.
- 2 Input port 2 accepts reference entities with type `Order` to storage 2.
- 3 When a reference `Order` arrives at storage 2, its attribute data is recorded as the reference value, and the entity is destroyed.
- 4 The `Order` arrival invokes an iteration event at storage 1 to search for an `Item` carrying data that is equal to the reference value.
- 5 If a match is found, the matching item is forwarded to output port 1 and the iteration ends.
- 6 If the match is not found, a new `Item` is generated at storage 1 with a matching attribute value and forwarded to output port 1.

See the Code to Generate the Custom Storage Block with Multiple Storages

```

classdef CustomBlockTwoEntityStorages < matlab.DiscreteEventSystem & ...
    matlab.system.mixin.Propagates
    % Select from stored entities based on a lookup key.

    properties (Nontunable)
        % Capacity
        capacity = 100;
    end

    properties (DiscreteState)
        InputKey;
    end

    methods (Access=protected)

        function num = getNumInputsImpl(~)
            num = 2;
        end

        function num = getNumOutputsImpl(~)
            num = 1;
        end

        function [entityTypes] = getEntityTypesImpl(obj)
            entityTypes = [obj.entityType('Item'), ...
                obj.entityType('Order')];
        end

        function [inputTypes, outputTypes] = getEntityPortsImpl(~)
            inputTypes = {'Item' 'Order'};
            outputTypes = {'Item'};
        end

        function [storageSpecs, I, O] = getEntityStorageImpl(obj)
            storageSpecs = [obj.queueFIFO('Item', obj.capacity)...
                obj.queueFIFO('Order', obj.capacity)];
            I = [1 2];
            O = 1;
        end

        function [sz, dt, cp] = getDiscreteStateSpecificationImpl(obj, name)
            sz = 1;
            dt = 'double';
            cp = false;
        end

        function resetImpl(obj)
            obj.InputKey = 0;
        end
    end

    methods

        function [Order,events] = OrderEntry(obj, storage, Order, source)
            % A key entity has arrived; record the Inputkey value.
            obj.InputKey = Order.data.Key;
            % Schedule an iteration of the entities in storage 1.
            % Destroy input key entity.
            events = [obj.eventIterate(1, '') ...
                obj.eventDestroy()];
        end
    end
end

```

```

        coder.extrinsic('fprintf');
        fprintf('Order Key Value: %f\n', Order.data.Key);
    end

    function [Item,events,continueIter] = ItemIterate(obj,...
        storage, Item, tag, cur)
        % Find entities with matching key.
        events = obj.initEventArray;
        continueIter = true;

        if (Item.data.Attributel == obj.InputKey)
            events = obj.eventForward('output', 1, 0.0);
            % If a match is found, the iteration ends and the state is reset.
            continueIter = false;

        elseif cur.size == cur.position
            % If a match is not found, a new matching entity is generated.
            events = obj.eventGenerate(1,'mygen',0.0,100);
        end
    end

    function [Item,events] = ItemGenerate(obj,storage,Item,tag)
        % Specify event actions when entity generated in the storage.
        Item.data.Attributel = obj.InputKey;
        events = obj.eventForward('output',1,0.0);
    end
end
end
end

```

Custom Block Behavior

- 1 Discrete state variable `InputKey` represents the recorded reference value from `Order`, which is used to select corresponding `Item`.

```

properties (DiscreteState)
    InputKey;
end

```

- 2 The block has two storages with FIFO behavior. Storage 1 supports entities with type `Item`, and storage 2 supports entities with type `Order`. The block has two input ports and one output port. Input port 1 and output port 1 are connected to storage 1. Input port 2 is connected to storage 2. For more information about declaring ports and storages, see “Implement a Discrete-Event System Object with MATLAB Discrete-Event System Block” on page 9-7.

```

function num = getNumInputsImpl(~)
    num = 2;
end

function num = getNumOutputsImpl(~)
    num = 1;
end

function [entityTypes] = getEntityTypesImpl(obj)
    entityTypes = [obj.entityType('Item'), ...
        obj.entityType('Order')];
end

```

```

function [inputTypes, outputTypes] = getEntityPortsImpl(~)
    inputTypes = {'Item' 'Order'};
    outputTypes = {'Order'};
end

function [storageSpecs, I, O] = getEntityStorageImpl(obj)
    storageSpecs = [obj.queueFIFO('Item', obj.capacity)...
        obj.queueFIFO('Order', obj.capacity)];
    I = [1 2];
    O = 1;
end

```

- 3 Specify the discrete state and reset the state `InputKey`. For more information about states in discrete-event systems, see “Custom Entity Generator Block with Signal Input” on page 9-31.

```

function [sz, dt, cp] = getDiscreteStateSpecificationImpl(obj, name)
    sz = 1;
    dt = 'double';
    cp = false;
end

function resetImpl(obj)
    obj.InputKey = 0;
end

```

- 4 When `Order` arrives at storage 2, its data `Key` is recorded in the discrete state variable `Obj.InputKey`. This entry also invokes an iteration event at storage 1 and another event to destroy `Order`.

```

function [Order, events] = OrderEntry(obj, storage, Order, source)
    % A key entity has arrived; record the Inputkey value.
    obj.InputKey = Order.data.Key;
    % Schedule an iteration of the entities in storage 1.
    % Destroy input key entity.
    events = [obj.eventIterate(1, '') ...
        obj.eventDestroy()];
    coder.extrinsic('fprintf');
    fprintf('Order Key Value: %f\n', Order.data.Key);
end

```

- 5 The purpose of the iteration is to find items with data that matches `InputKey`.

```

function [Item,events,continueIter] = ItemIterate(obj,...
    storage, Item, tag, cur)
    % Find entities with matching key.
    events = obj.initEventArray;
    continueIter = true;

    if (Item.data.Attribute1 == obj.InputKey)
        events = obj.eventForward('output', 1, 0.0);
        % If a match is found, the iteration ends and the state is reset.
        continueIter = false;

    elseif cur.size == cur.position
        % If a match is not found, this invokes an entity generation event.
        events = obj.eventGenerate(1,'mygen',0.0,100);
    end
end

```

- 6 Generate an entity with type `entity1` and a matching `Key` value. Then, forward the generated entity to output port 1.

```
function [Item,events] = ItemGenerate(obj,storage,Item,tag)
    % Specify event actions when entity generated in the storage.
    Item.data.Attribute1 = obj.InputKey;
    events = obj.eventForward('output',1,0.0);
end
```

Implement the Custom Block

- 1 Save the `.m` file as `CustomBlockTwoEntityStorages`. Link the System object to a SimEvents model using a MATLAB Discrete-Event System block. For more information about linking, see “Create Custom Blocks Using MATLAB Discrete-Event System Block” on page 9-2.
- 2 Create a SimEvents model including the MATLAB Discrete-Event System block, two Entity Generator blocks, and an Entity Terminator block. Connect the blocks as shown in the model.

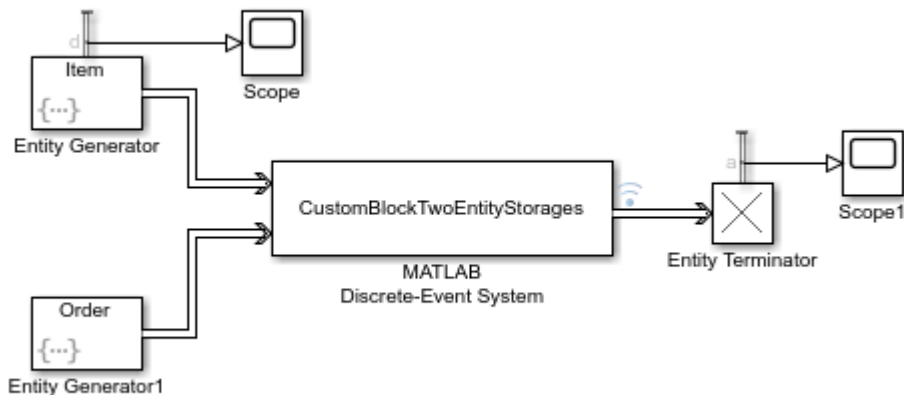

- 3 In the Entity Generator block:
 - a In the **Entity generation** tab, set the **Generate entity at simulation start** to off.
 - b In the **Entity type** tab, set the **Entity type name** as `Item`.
 - c In the **Event Actions** tab, in the **Generate action field** enter:

```
entity.Attribute1 = randi([1 3]);
```

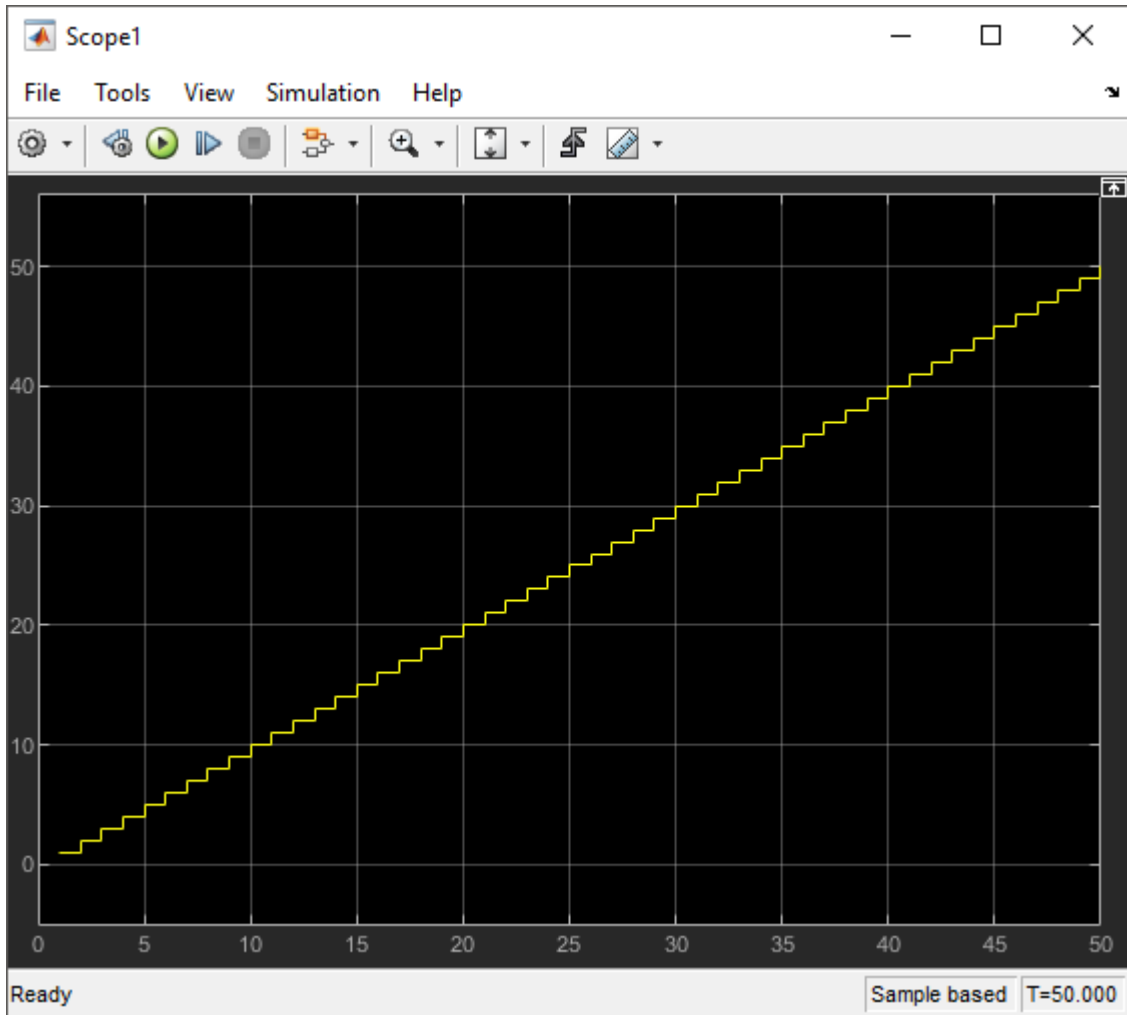
- b** In the Diagnostic Viewer, observe the incoming Key reference values carried by 10 entities that enter storage 2 and are destroyed afterward.

```

Order Key Value: 4.000000
Order Key Value: 4.000000
Order Key Value: 1.000000
Order Key Value: 4.000000
Order Key Value: 3.000000
Order Key Value: 1.000000
Order Key Value: 2.000000
Order Key Value: 3.000000
Order Key Value: 4.000000
Order Key Value: 4.000000

```

- c The Simulation Data Inspector shows the departing items and their `Attribute1` values. The values match the `Key` values displayed in the Diagnostic Viewer.

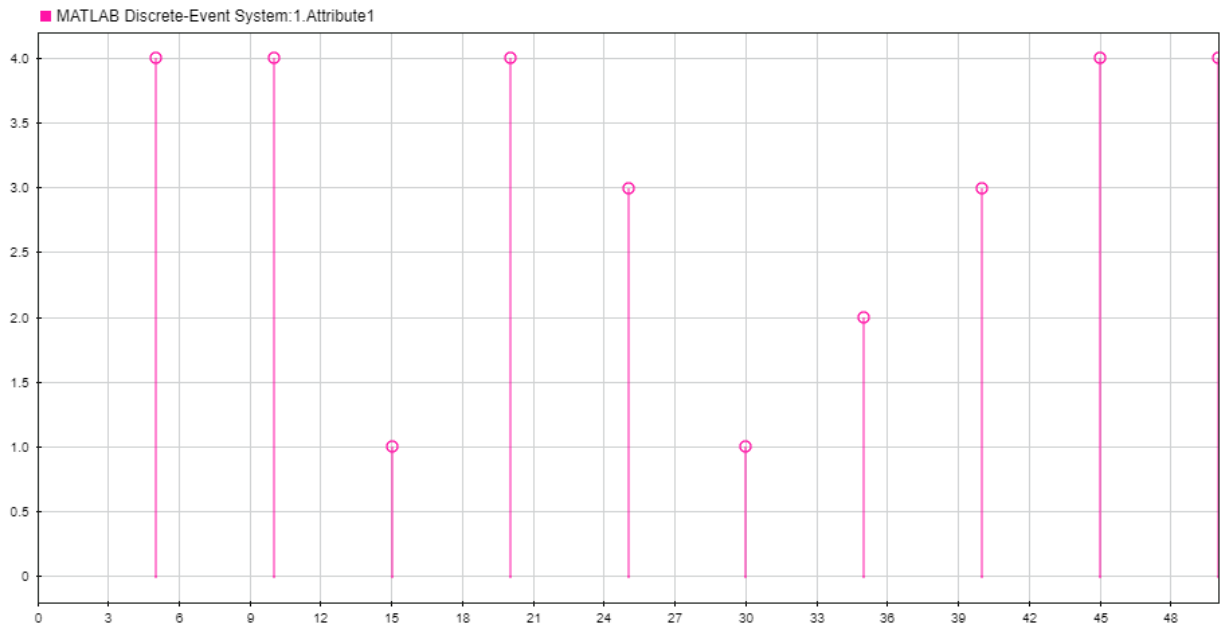

Also observe 5 entities departing with `Attribute1` value 4. These entities are generated in storage 2 because `Attribute1` cannot have the value 4 for the entities generated by the Entity Generator block.

See Also

[entry](#) | [generate](#) | [getEntityPortsImpl](#) | [getEntityStorageImpl](#) | [iterate](#) | [matlab.DiscreteEventSystem](#) | [matlab.System](#)

More About

- “Integrate System Objects Using MATLAB System Block” (Simulink)
- “Create a Discrete-Event System Object” on page 9-58
- “Generate Code for MATLAB Discrete-Event System Blocks” on page 9-65
- “Call Simulink Function from a MATLAB Discrete-Event System Block” on page 9-75

Create a Custom Resource Acquirer Block

This example shows how to use resource management methods to create a custom entity storage block in which entities acquire resources from specified Resource Pool blocks.

Suppose that you manage a facility that produces parts from two different materials, material 1 and material 2, to fulfil orders. After a part is produced, it is evaluated for quality assurance.

Two testing methods for quality control are:

- Test 1 is used for parts that are produced from material 1.
- Test 2 is used for parts that are produced from material 2

After the production phase, parts are tagged based on their material to apply the correct test.

To generate the custom behavior, you create a discrete-event System object using the `matlab.DiscreteEventSystem` class methods for resource management.

Create the Discrete-Event System Object

Generate a custom entity storage block with one input, one output, and one storage element.

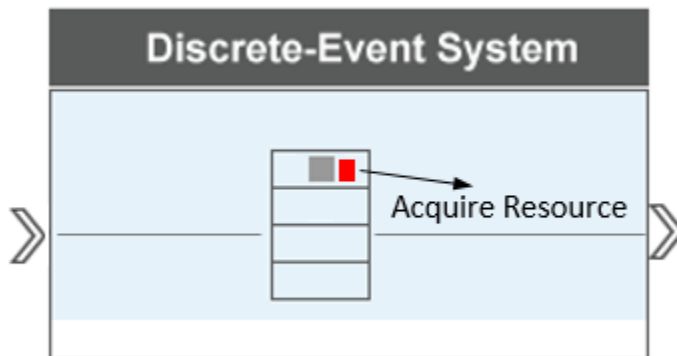

The block accepts an entity of type `Part` to its storage with capacity 1. The entity has an attribute `Test` to indicate the material from which the part is produced. Based on the

value of the attribute, the entity acquires a resource from the specified Resource Pool block and departs the block to be tested.

See the Code to Generate the Custom Block to Acquire Resources

```
classdef CustomBlockAcquireResources < matlab.DiscreteEventSystem
    % Custom resource acquire block example.

    methods(Access = protected)

        function num = getNumInputsImpl(obj)
            num = 1;
        end

        function num = getNumOutputsImpl(obj)
            num = 1;
        end

        function entityTypes = getEntityTypesImpl(obj)
            entityTypes(1) = obj.entityType('Part');
        end

        function [input, output] = getEntityPortsImpl(obj)
            input = {'Part'};
            output = {'Part'};
        end

        function [storageSpec, I, O] = getEntityStorageImpl(obj)
            storageSpec(1) = obj.queueFIFO('Part', 1);
            I = 1;
            O = 1;
        end

        function resNames = getResourceNamesImpl(obj)
            % Define the names of the resources to be acquired.
            resNames = obj.resourceType('Part', {'Test1', 'Test2'});
        end

    end

    methods

        function [entity,events] = entry(obj, storage, entity, source)
            % On entity entry, acquire a resource from the specified pool.
            if entity.data.Test == 1
                % If the entity is produced from Material1, request Test1.
                resReq = obj.resourceSpecification('Test1', 1);
            else
                % If the entity is produced from Material2, request Test2.
                resReq = obj.resourceSpecification('Test2', 1);
            end
            % Acquire the resource from the corresponding pool.
            events = obj.eventAcquireResource(resReq, 'TestTag');
        end

        function [entity,events] = resourceAcquired(obj, storage,...
            entity, resources, tag)
            % After the resource acquisition, forward the entity to the output.
            events = obj.eventForward('output', storage, 0.0);
        end
    end
end
```

```

end
end
end

```

Custom Block Behavior

- 1 Define Test1 and Test2 type resources to be acquired by the entity type Part.

```

function resNames = getResourceNamesImpl(obj)
    % Define the names of the resources to be acquired.
    resNames = obj.resourceType('Part', {'Test1', 'Test2'}) ;
end

```

- 2 The entity enters the storage. If its entity.data.Test value is 1, the entity is produced from Material1. The entity acquires 1 resource from the Resource Pool block with resources of type Test1. Similarly, If its entity.data.Test value is 2, the entity acquires one resource from the Resource Pool block with resources of type Test2.

methods

```

function [entity,events] = entry(obj, storage, entity, source)
    % On entity entry, acquire a resource from the specified pool.
    if entity.data.Test == 1
        % If the entity is produced from Material1, it acquires resource of type Test1.
        resReq = obj.resourceSpecification('Test1', 1);
    else
        % If the entity is produced from Material2, it acquires resource of type Test2.
        resReq = obj.resourceSpecification('Test2', 1);
    end
    % Acquire the resource from the corresponding pool.
    events = obj.eventAcquireResource(resReq, 'TestTag');
end

function [entity,events] = resourceAcquired(obj, storage,...
    entity, resources, tag)
    % After the resource acquisition, forward the entity to the output.
    events = obj.eventForward('output', storage, 0.0);
end
end

```

After the resource is successfully acquired, the resourceAcquired invokes the forwarding of the entity.

Implement the Custom Block

- 1 Save the .m file as CustomBlockAcquireResources. Link the System object to a SimEvents model by using a MATLAB Discrete-Event System block. For more

information about linking, see “Create Custom Blocks Using MATLAB Discrete-Event System Block” on page 9-2.

- 2 Create a SimEvents model using a MATLAB Discrete-Event System block, an Entity Generator block and an Entity Terminator block, and two Resource Pool blocks. Connect the blocks as shown in the diagram.

Label Entity Generator block as Part Generator and Entity Terminator block as Departure for Testing.

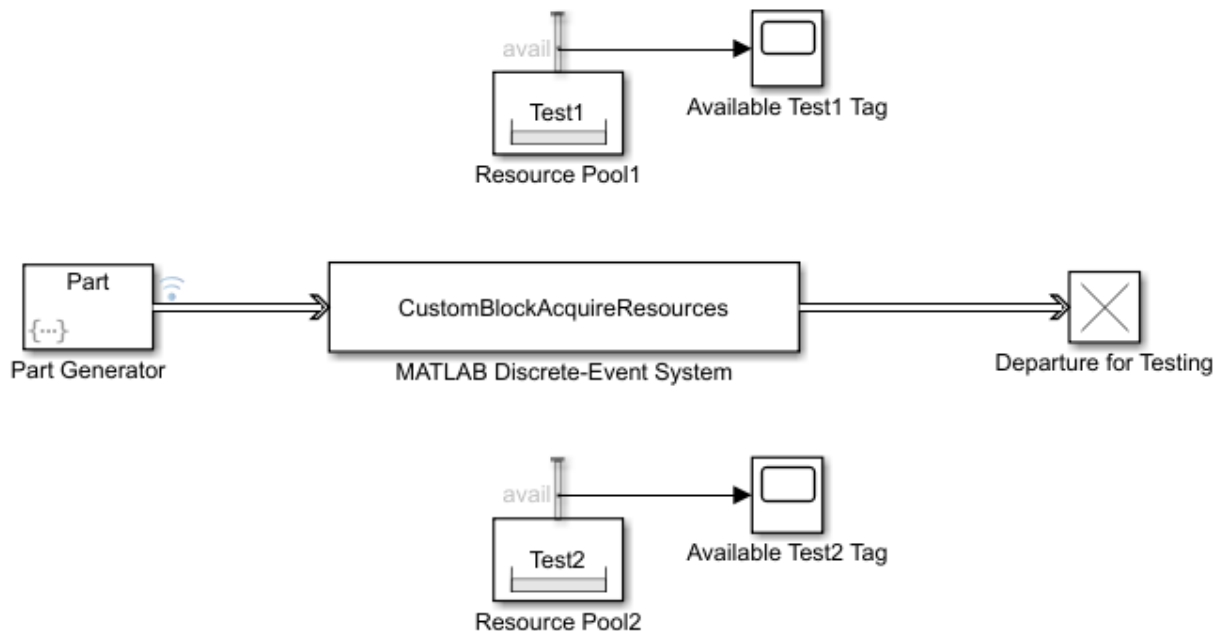

- 3 In the Part Generator:

- a In the **Entity generation** tab, set the **Generate entity at simulation start** to off.
- b In the **Entity type** tab, set the **Entity type name** as Part and **Attribute Name** to Test.
- c In the **Event Actions** tab, in the **Generate action field** enter:



```
entity.Test= randi([1 2]);
```

Parts are generated with intergeneration time 1 and their `Test` attribute value is 1 or 2 to indicate the material type.

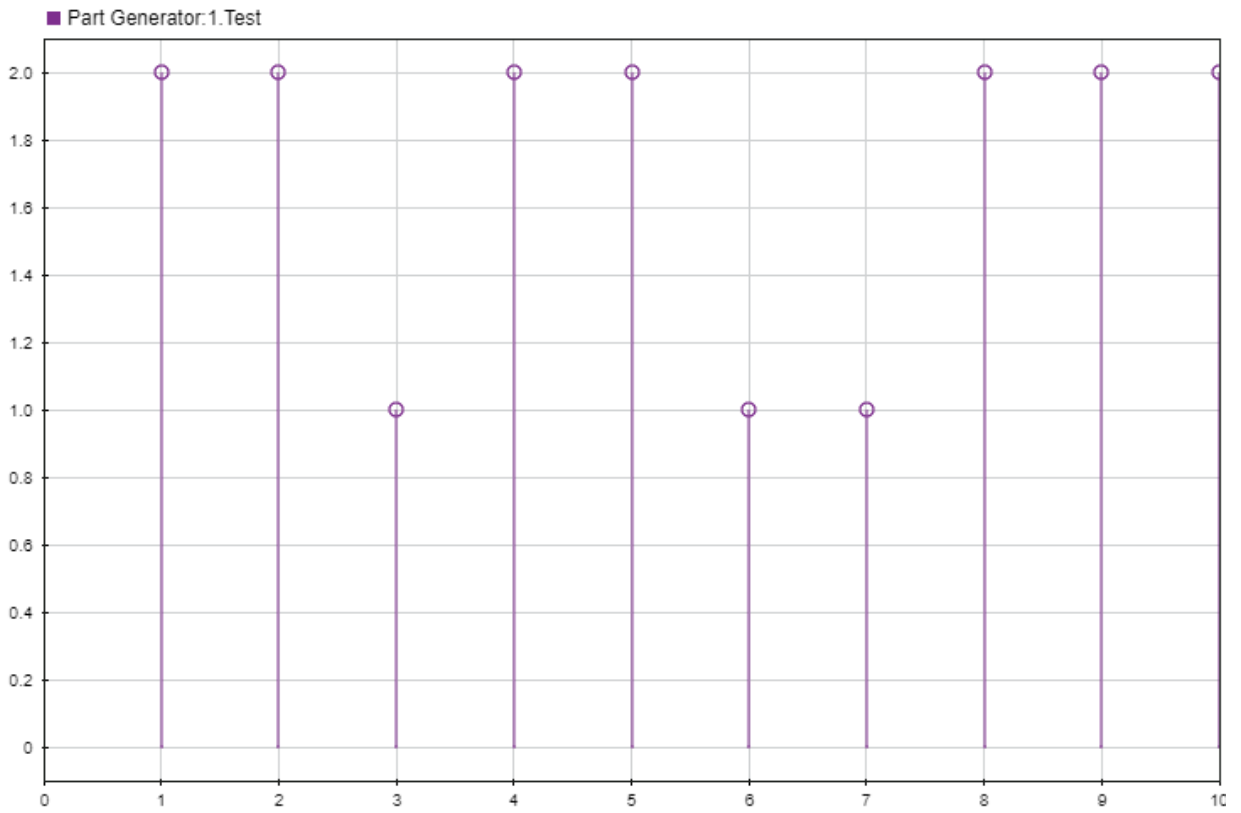
- 4 In the Resource Pool block:
 - a Set the **Resource name** to `Test1` and the **Reusable upon release** parameter to `off`.
 - b In the **Statistics** tab, output the **Amount available, avail** statistic and connect it to a scope.
- 5 In the Resource Pool1 block:
 - a Set the **Resource name** to `Test2` and the **Reusable upon release** parameter to `off`.
 - b In the **Statistics** tab, output the **Amount available, avail** statistic and connect it to a scope.
- 6 Right-click the entity path from Part Generator to the MATLAB Discrete-Event System block and select **Log Selected Signals**.
- 7 Simulate the model.
 - Observe the `Test` attribute values of the incoming entities to the custom block. Three entities require test 1 and seven entities requires test 2.

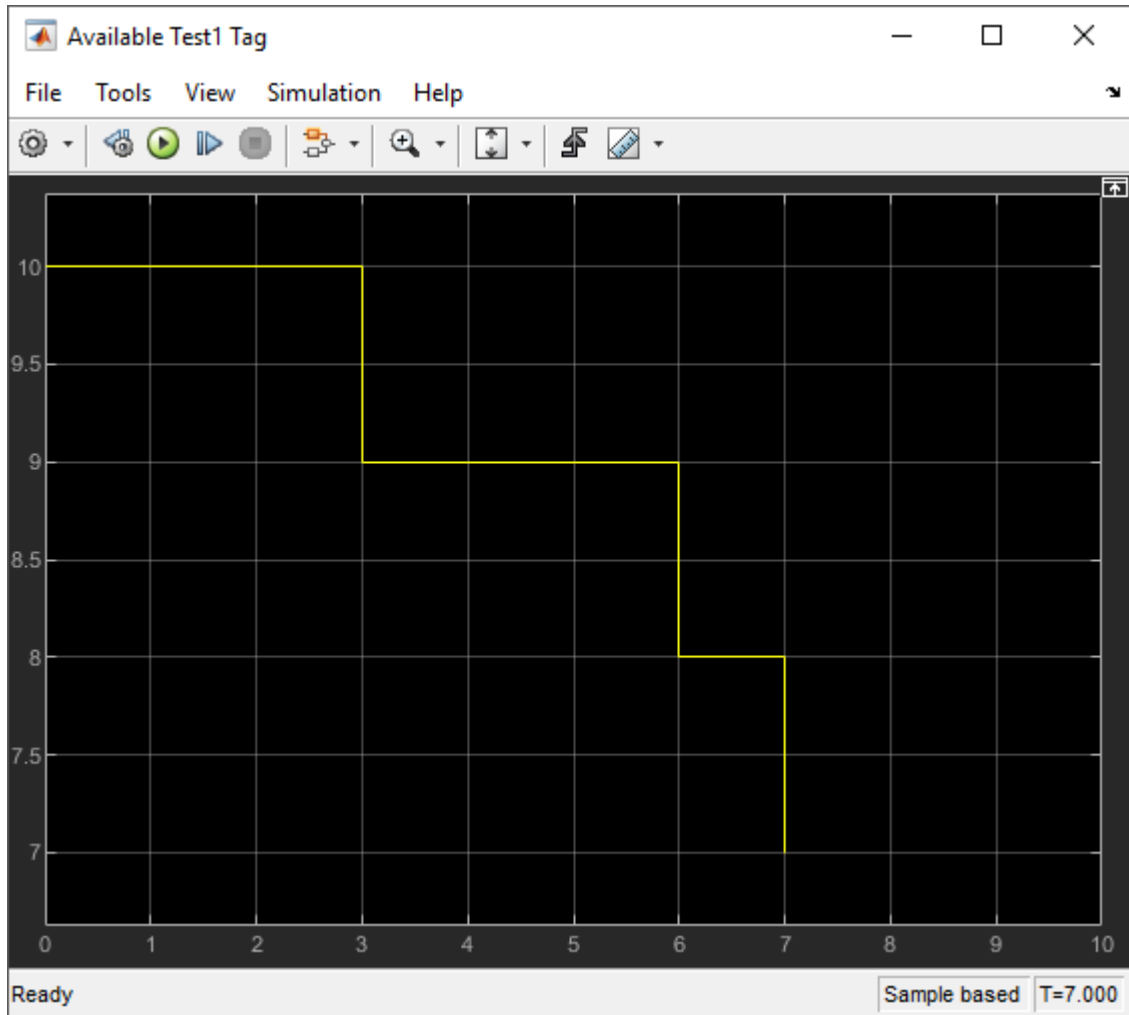

- Observe that three resources of type Test1 are acquired by entities.



- Observe that seven resources of type Test2 are acquired by entities.

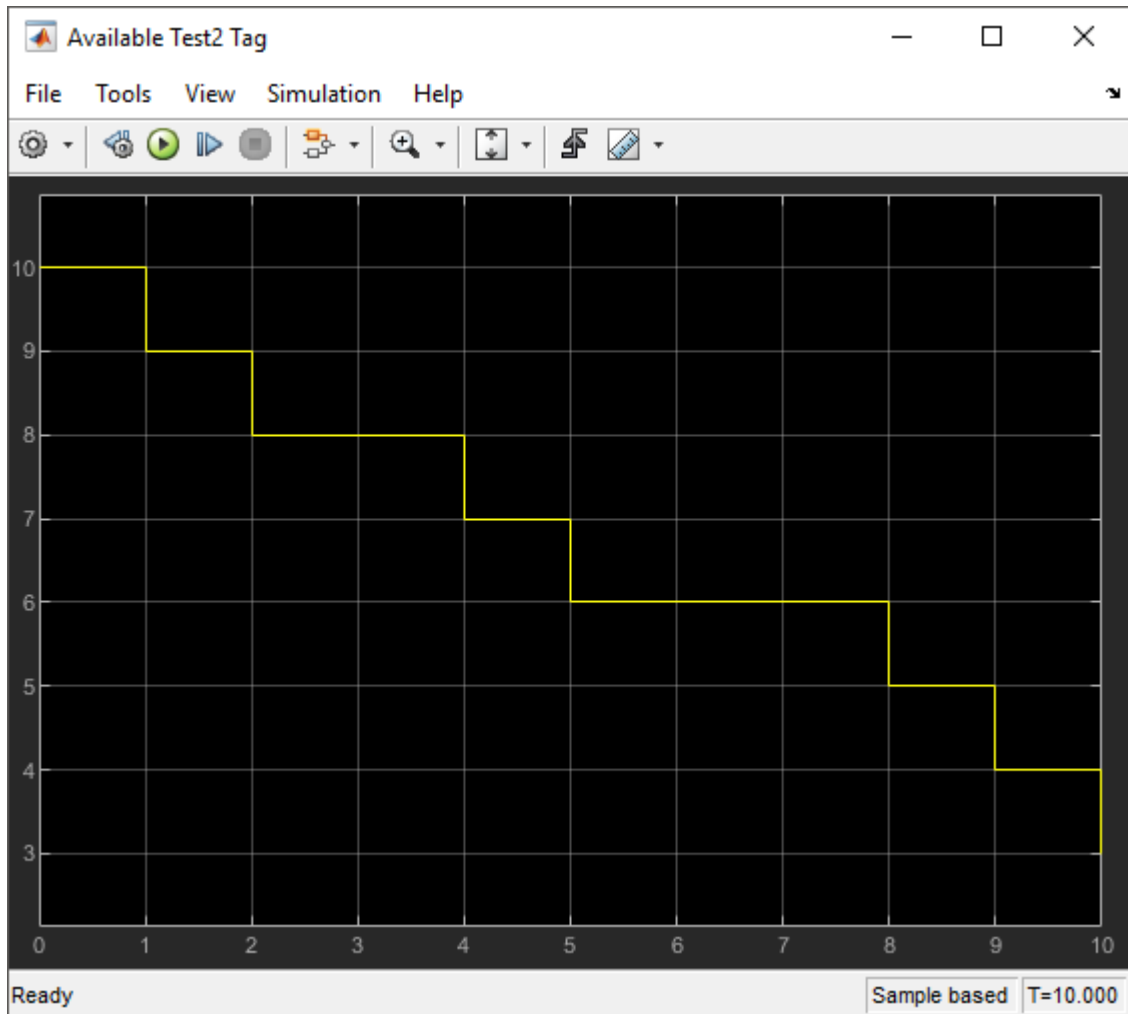

See Also

[cancelAcquireResource](#) | [entry](#) | [eventAcquireResource](#) | [getResourceNamesImpl](#) | [matlab.DiscreteEventSystem](#) | [matlab.System](#) | [resourceAcquired](#) | [resourceSpecification](#)

More About

- “Integrate System Objects Using MATLAB System Block” (Simulink)
- “Create a Discrete-Event System Object” on page 9-58
- “Generate Code for MATLAB Discrete-Event System Blocks” on page 9-65
- “Call Simulink Function from a MATLAB Discrete-Event System Block” on page 9-75

Create a Discrete-Event System Object

In this section...
"Methods" on page 9-59
"Inherited Methods from matlab.System Class" on page 9-62
"Inherited Methods from matlab.system.mixin Package" on page 9-62
"Reference and Extract Entities" on page 9-63

The MATLAB Discrete-Event System block allows you to author a custom discrete-event System object and use it in SimEvents models. To author event-driven entity-flow systems, the block uses discrete-event System object with the `matlab.DiscreteEventSystem` class, which inherits and extends the `matlab.System` class.

You can optionally inherit a subset of methods from the `matlab.system.mixin` package by inheriting `matlab.System.mixin.Propagates`, `matlab.System.mixin.CustomIcon`, or `matlab.System.mixin.SampleTime` classes. This diagram shows the relationships between the classes in the creation of a discrete-event System object.

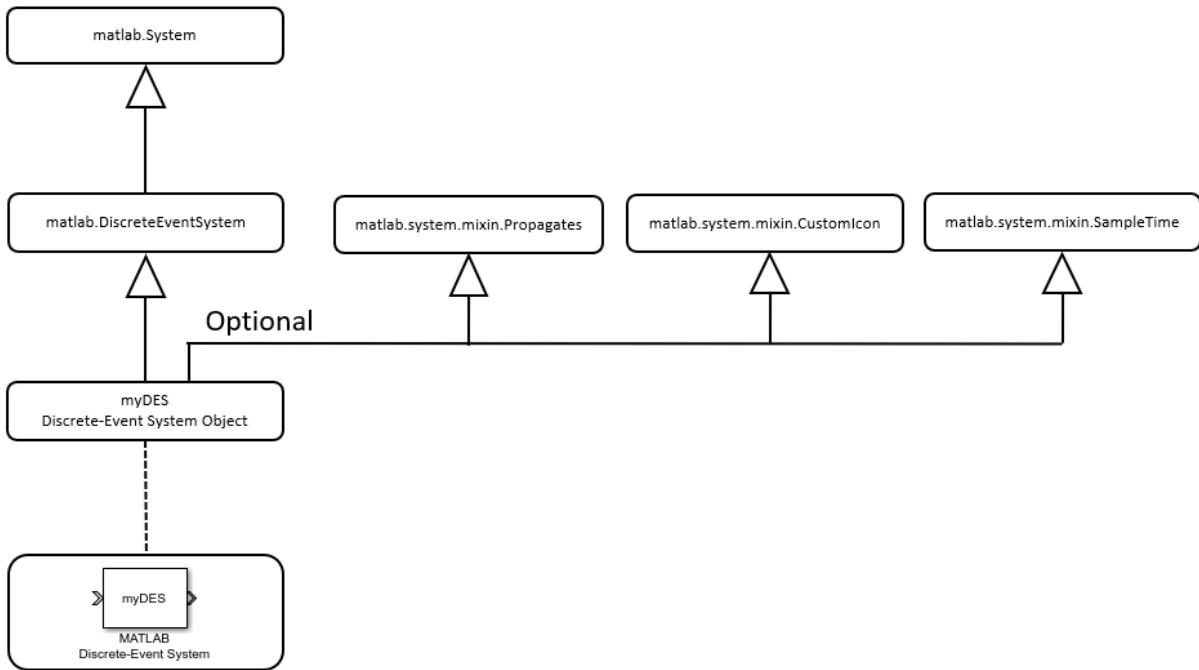

Methods

The `matlab.DiscreteEventSystem` class provides methods that let you work with these elements of a discrete-event system:

- Define properties of the object entity types, ports, and storage
 - `getEntityPortsImpl` — Define input ports and output ports of discrete-event system
 - `getEntityStorageImpl` — Define entity storage elements of discrete-event system
 - `getEntityTypesImpl` — Define entity types of discrete-event system
- Event initialization
 - `setupEvents` — Initialize entity generation events
- Runtime behavior of the object

- `blocked` — Event action when entity forward fails
- `destroy` — Event action upon entity destruction
- `entry` — Event action when entity enters storage element
- `exit` — Event action before entity exit from storage
- `generate` — Event action upon entity creation
- `iterate` — Event action when entity iterates
- `modified` — Event action upon entity modification by the Entity Find block
- `resourceAcquired` — Specify event actions upon successful resource acquisition.
- `resourceReleased` — Specify event actions upon successful resource release.
- `testEntry` — Event action to accept or refuse entity
- `timer` — Event action when timer completes

While implementing these methods, define entity type, entity storage, create, schedule, and cancel events. Use these functions:

- Define entity type
 - `entityType` — Define entity type
- Define entity storage
 - `queueFIFO` — Define first-in first-out (FIFO) queue storage
 - `queueLIFO` — Define last-in last-out (LIFO) queue storage
 - `queuePriority` — Define priority queue storage
 - `queueSysPriority` — Define system priority queue storage
- Create events
 - `eventGenerate` — Create entity generate event
 - `eventIterate` — Create entity iterate event
 - `eventTimer` — Create entity timer event
 - `eventForward` — Create entity forward event
 - `eventDestroy` — Create entity destroy event
 - `eventTestEntry` — Create an event to indicate that the acceptance policy for the storage has changed and the storage retests arriving entities
 - `eventAcquireResource` — Create a resource-acquiring event

- `eventReleaseResource` — Create an event to release previously acquired resources(This method allows for partial resource release)
- `eventReleaseAllResources` — Create an event to release all the resources acquired by an entity
- Cancel events
 - `cancelDestroy` — Cancel previously scheduled entity destroy event
 - `cancelForward` — Cancel entity forward event
 - `cancelGenerate` — Cancel previously scheduled entity generation event
 - `cancelIterate` — Cancel previously scheduled iterate event
 - `cancelTimer` — Cancel previously scheduled timer event
 - `cancelAcquireResource` — Cancel previously scheduled resource acquisition event
- Resource Management
 - `getResourceNamesImpl` — Define resource pools from which the discrete-event system acquires the resources
 - `resourceType` — Specify an entity type and the name of the resources to be acquired by the specified entity
 - `eventAcquireResource` — Create a resource-acquiring event
 - `eventReleaseResource` — Create an event to release previously acquired resources (This method allows for partial resource release)
 - `eventReleaseAllResources` — Create an event to release all the resources acquired by an entity
 - `cancelAcquireResource` — Cancel previously scheduled resource acquisition event
 - `resourceSpecification` — Specify the type and amount of resources for `eventAcquireResource` or `eventReleaseResource` requests
 - `initResourceArray` — Initialize a `resourceSpecification` array, required for code generation
 - `resourceAcquired` — Specify event actions upon successful resource acquisition
 - `resourceReleased` — Specify event actions upon successful resource release

Inherited Methods from `matlab.System` Class

Inheriting `matlab.DiscreteEventSystem` class also inherits a subset of the `matlab.System` class methods.

<code>getHeaderImpl</code>	Header for System object display
<code>getPropertyGroupsImpl</code>	Property groups for System object display
<code>isInactivePropertyImpl</code>	Inactive property status
<code>validatePropertiesImpl</code>	Validate property values
<code>processTunedPropertiesImpl</code>	Action when tunable properties change
<code>getNumInputsImpl</code>	Number of inputs to step method
<code>getInputNamesImpl</code>	Names of System block input ports
<code>getNumOutputsImpl</code>	Number of outputs from step method
<code>getOutputNamesImpl</code>	Names of System block output ports
<code>getDiscreteStateImpl</code>	Discrete state property values
<code>setupImpl</code>	Initialize System object
<code>resetImpl</code>	Reset System object states
<code>releaseImpl</code>	Release resources
<code>loadObjectImpl</code>	Load System object from MAT file
<code>saveObjectImpl</code>	Save System object in MAT file
<code>infoImpl</code>	Information about System object

For more information about these methods, see “Customize System Objects for Simulink” (Simulink).

Inherited Methods from `matlab.system.mixin` Package

You can inherit other methods that require the inheritance of additional classes from the `matlab.system.mixin` package. For example, to specify a discrete state by using `getDiscreteStateSpecificationImpl`, inherit the `matlab.system.mixin.Propagates` class. For an example of inheriting this class, see “Selection Server - Select Specific Entities from Server”.

Inherited Methods from `matlab.System.mixin.Propagates` Class

To use the methods inherited from `matlab.System.mixin.Propagates` class, you must subclass from this class in addition to the `matlab.DiscreteEventSystem` base class. Type the following syntax as the first line of your class definition file, where `ObjectName` is the name of your object.

```
classdef ObjectName < matlab.DiscreteEventSystem & matlab.system.mixin.Propagates
```

This list contains the methods inherited from `matlab.system.mixin.Propagates` class.

<code>getOutputSizeImpl</code>	Sizes of output ports
<code>getOutputDataTypeImpl</code>	Data types of output ports
<code>isOutputComplexImpl</code>	Complexity of output ports
<code>getDiscreteStateSpecificationImpl</code>	Discrete state size, data type, and complexity

Inherited Methods from `matlab.System.mixin.CustomIcon` Class

To inherit methods from the `matlab.System.mixin.CustomIcon` class, type the following syntax as the first line of your class definition file.

```
classdef ObjectName < matlab.DiscreteEventSystem & matlab.system.mixin.CustomIcon
```

<code>getIconImpl</code>	Name to display as block icon
--------------------------	-------------------------------

Inherited Methods from `matlab.System.mixin.SampleTime` Class

To inherit methods from the `matlab.System.mixin.SampleTime` class, type the following syntax as the first line of your class definition file.

```
classdef ObjectName < matlab.DiscreteEventSystem & matlab.system.mixin.SampleTime
```

<code>getSampleTime</code>	Query sample time
----------------------------	-------------------

Reference and Extract Entities

- 1 When referencing entity attributes or system properties in a discrete-event System object, use these formats:

Attribute or Property	Format	Access
attribute	<code>entity.data.attribute_name</code>	Read/write
priority property	<code>entity.sys.priority</code>	Read/write
ID property	<code>entity.sys.id</code>	Read-only

- 2 If an entity that is a part of a MATLAB Discrete-Event System block is requested for extraction, the `exit` method of the block is triggered. When the `exit` method is called, its **destination** argument is set to `extract`. See [modified for entity modification](#).

See Also

`matlab.DiscreteEventSystem` | `matlab.System`

More About

- “Integrate System Objects Using MATLAB System Block” (Simulink)
- “Create Custom Blocks Using MATLAB Discrete-Event System Block” on page 9-2
- “Customize Discrete-Event System Behavior Using Events and Event Actions” on page 9-69

Generate Code for MATLAB Discrete-Event System Blocks

To improve simulation performance, you can configure the MATLAB Discrete-Event System to simulate using generated code. With the **Simulate using** parameter set to Code generation option, the block simulates and generates code using only MATLAB functions supported for code generation.

MATLAB Discrete-Event System blocks support code reuse for models that have multiple MATLAB Discrete-Event System blocks using the same System object source file. Code reuse enables the code to be generated only once for the blocks sharing the System object.

Migrate Existing MATLAB Discrete-Event System System object

Starting in R2017b, the MATLAB Discrete-Event System block can simulate using generated code. Existing applications continue to work with the **Simulate using** parameter set to Interpreted execution.

If you want to generate code for the block using MATLAB discrete-event system acceleration, update the System object code using these guidelines. For an example of updated MATLAB Discrete-Event System System object, see the `seExampleSchedulerClass` file in the Develop Custom Scheduler of a Multicore Control System example.

Replace Renamed `matlab.DiscreteEventSystem` Methods

To take advantage of simulation with code generation for the `matlab.DiscreteEventSystem` class:

- 1 In the `matlab.DiscreteEventSystem` application file, change these method names to the new names:

Old Method Name	New Method Name
<code>blockedImpl</code>	<code>blocked</code>
<code>destroyImpl</code>	<code>destroy</code>
<code>entryImpl</code>	<code>entry</code>

Old Method Name	New Method Name
exitImpl	exit
generateImpl	generate
iterateImpl	iterate
setupEventsImpl	setupEvents
timerImpl	timer

- In the code, move the renamed method definitions from a protected area to a public area for each `matlab.DiscreteEventSystem` method.

Initialize System Properties

Initialize System object properties in the properties section. Do not initialize them in the constructor or other methods. In other words, you cannot use variable-size for System object properties.

Initialize Empty Arrays of Events

Use the `initEventArray` to initialize arrays.

Before	After
<code>function events = setupEventsImpl(obj)</code>	<code>function events = setupEvents(obj) events = obj.initEventArray;</code>

Append Elements to Array of Structures

Append elements to array of structures. For example:

Before	After
<code>events(id) = obj.eventGenerate(1, numEvents(id), [events obj.eventGenerate(1, 0, obj.Priorities(id)); %#ok<*AGROW></code>	<code>events(id), [events obj.eventGenerate(1, int2str(id), 0, obj.Priorities(id))]; %#ok<AGROW></code>

Replace Functions That Do Not Support Code Generation

Replace functions that do not support code generation with functional equivalents that support code generation. For example:

Before	After
<code>events(id) = obj.eventGenerate(1, numEvents, [events obj.eventGenerate(1, 0, obj.Priorities(id)); %#ok<*AGROW></code>	<code>events(id) = [events obj.eventGenerate(1, numEvents, [events obj.eventGenerate(1, 0, obj.Priorities(id))]; %#ok<AGROW></code>

int2str(id)

Declare Functions That Do Not Support Code Generation

For functions that do not support code generation and that do not have functional equivalents, use the `coder.extrinsic` function to declare those functions as extrinsic. For example, `str2double` does not have a functional equivalent. Before calling the `coder.extrinsic`, make the returned variable the same data type as the function you are identifying. For example:

Before	After
<code>id = str2double(tag);</code>	<code>coder.extrinsic('str2double'); id = 1; id = str2double(tag);</code>

- Do not pass System object to functions that are declared as extrinsic.
- Declare only static System object methods as extrinsic.

Replace Cell Arrays

Replace cell arrays with matrices or arrays of structures.

Before	After
<code>entity.data.execTime = obj.ExecTimes{id}(1);</code>	<code>entity.data.execTime = obj.ExecTimes(id, 1);</code>

Change Flags to Logical Values

Change flags from values such as 1 and 0 to logical values, such as true and false.

Manage Global Data

Manage global data while simulating with code generation using one of these:

- `evalin` and `assignin` functions in the MATLAB workspace
- “Static Data Object” (MATLAB)

Move Logging and Graphical Functions

Many MATLAB logging and graphical functions do not support code generation. You can move logging and graphical functions into:

- A new `matlab.DiscreteEventSystem` object and configure the associated MATLAB Discrete-Event System block to simulate using `Interpreted` execution mode.
- An existing `simevents.SimulationObserver` object

Replace Persistent Variables

Replace persistent variable by declaring a System object property. See “Create System Objects” (MATLAB) for more information.

Limitations of Code Generation with Discrete-Event System Block

Limitations include:

- No “Global Variables” (MATLAB)
- “System Objects in MATLAB Code Generation” (Simulink)
- “MATLAB System Block Limitations” (Simulink)

See Also

`blocked` | `cancelForward` | `cancelGenerate` | `cancelIterate` | `cancelTimer` | `entry` | `eventForward` | `generate` | `getEntityPortsImpl` | `getEntityTypesImpl` | `iterate` | `matlab.DiscreteEventSystem` | `matlab.System` | `queueFIFO` | `setupEvents` | `timer`

More About

- “Integrate System Objects Using MATLAB System Block” (Simulink)
- “Create Custom Blocks Using MATLAB Discrete-Event System Block” on page 9-2
- “Create a Discrete-Event System Object” on page 9-58

Customize Discrete-Event System Behavior Using Events and Event Actions

In this section...

“Event Types and Event Actions” on page 9-69

“Event Identifiers” on page 9-72

You can customize the behavior of a discrete-event system by defining events and event actions.

You can:

- Schedule events
- Define event actions in response to events
- Initialize events
- Cancel events

Event Types and Event Actions

Event Types

A discrete-event system can have these event types and their targets.

Event type	Target	Purpose
eventAcquireResource	Entity	Allow an entity to acquire one or more resources.
eventDestroy	Entity	Destroy an existing entity in storage.
eventForward	Entity	Move an entity from its current storage to another storage or output port.
eventIterate	Storage	Iterate and process each entity in storage.
eventReleaseResource	Entity	Allow an entity to release one or more resources.

Event type	Target	Purpose
eventReleaseAllResources	Entity	Allow an entity to release all previously acquired resources.
eventTestEntry	Storage	Create an event to indicate that the storage acceptance policy is changed and the storage retests the arriving entities.
eventTimer	Entity	Create a timer event.
eventGenerate	Storage	Create an entity inside storage.

- Forward events

If a forward event fails because of blocking, the forward event remains active. When space becomes available, the discrete-event system reschedules the forward event for immediate execution.

- Tagging events

You can schedule multiple events of the same type for the same actor. When using multiple events of the same type, use tags to distinguish between the events. For example, an entity can have multiple timers with distinct tags. When one timer expires, you can use the `tag` argument of the `timer` method to differentiate which timer it is. For more information, see “Custom Entity Storage Block with Multiple Timer Events” on page 9-23.

If you schedule two events with the same tag on the same actor, the later event replaces the first event. If you schedule two events with different tags, the discrete-event system calls them separately.

Event Actions

When an event occurs, a discrete-event system responds to it by invoking a corresponding action. Implement these actions as System object methods. This table lists each action method and the triggering event.

Event Action	Triggering Event	Purpose
blocked	eventForward	Called if, upon execution of a forward event, the entity cannot leave due to blocking from the target storage.
destroy	eventDestroy	Called before an entity is destroyed and removed from storage.
entry	eventForward	Called upon an entity entry.
exit	eventForward	Called upon entity exit. When an entity is forwarded from storage 1 to storage 2, the exit action of storage 1 and then the entry action of storage 2 are called.
generate	eventGenerate	Called after a new entity is created inside a storage element.
iterate	eventIterate	Upon the execution of an Iterate event, this method is invoked for each entity from the front to the back of the storage, with the option of early termination. If entities need to be resorted due to key value changes, resorting takes place after the entire iteration is complete.
resourceAcquired	eventAcquireResource	Called after a successful resource acquisition. A resource acquisition is successful only if all of the specified resources are acquired.
resourceReleased	eventReleaseResource	Called after the resource release.

Event Action	Triggering Event	Purpose
testEntry	eventTestEntry	Called after the test entry event.
timer	eventTimer	Called upon executing a timer event of an entity.

Initialize Events

Use these methods to initialize empty arrays and events of a discrete-event system.

Event Type	Purpose
initEventArray	Initialize event array.
initResourceArray	Initialize a resource specification array.
setupEvents	Initialize entity generation events.

Cancel Previously Scheduled Events

Use these methods to cancel previously scheduled events of a discrete-event system.

Event type	Purpose
cancelAcquireResource	Cancel previously scheduled resource acquisition event
cancelDestroy	Cancel previously scheduled entity destroy event.
cancelForward	Cancel entity forward event.
cancelGenerate	Cancel previously scheduled entity generation event.
cancelIterate	Cancel previously scheduled iterate event.
cancelTimer	Cancel previously scheduled timer event.

Event Identifiers

There are two distinct identifiers for the events provided by the `matlab.DiscreteEventSystem` class.

- **Tag** — Use the `tag` as an input argument for a method.

```
event1 = obj.eventTimer('mytimer1', 2);
event2 = obj.eventTimer('mytimer2', 5);
```

Here, `mytimer1` and `mytimer2` are used as tags to refer to these two timer events.

- **Destination** — Use the destination to identify forward events.

```
event1 = obj.eventForward('storage', 2, 0.8);
event2 = obj.eventForward('output', 1, 2);
```

Here, `storage` and `output` are used to distinguish two forward events.

The events are not distinguishable when their identifiers are the same. This table shows how to identify an event when multiple events of the same type act on the same target.

Event Type	Identification
<code>eventAcquireResource</code>	Tag
<code>eventGenerate</code>	Tag
<code>eventIterate</code>	Tag
<code>eventReleaseResource</code>	Tag
<code>eventReleaseAllResources</code>	Tag
<code>eventTimer</code>	Tag
<code>eventForward</code>	Destination

Note If you define an event that is yet to be executed and a second event with the same type and identifier, the first event is replaced by the second one.

See Also

`blocked` | `destroy` | `entry` | `eventForward` | `eventGenerate` | `generate` | `matlab.DiscreteEventSystem` | `matlab.System` | `setupEvents`

More About

- “Create a Custom Entity Storage Block with Iteration Event” on page 9-17
- “Integrate System Objects Using MATLAB System Block” (Simulink)

- “Create Custom Blocks Using MATLAB Discrete-Event System Block” on page 9-2
- “Create a Discrete-Event System Object” on page 9-58

Call Simulink Function from a MATLAB Discrete-Event System Block

This example shows how to call a Simulink function when an entity enters the storage element of a custom discrete-event system block, and to modify entity attributes. For more information about calling Simulink functions from MATLAB System block, see “Call Simulink Functions from MATLAB System Block” (Simulink).

To represent this behavior, a custom block is generated with one input, one output, and one storage element. For more information about creating a custom entity storage block, see “Delay Entities with a Custom Entity Storage Block” on page 9-11.

See the Code that Calls Simulink Function to Modify Entity Attributes

```
classdef CustomEntityStorageBlockSLFunc < matlab.DiscreteEventSystem

    % A custom entity storage block with one input, one output, and one storage.

    % Nontunable properties
    properties (Nontunable)
        % Capacity
        Capacity = 1;
        % Delay
        Delay = 4;
    end

    methods (Access=protected)
        function num = getNumInputsImpl(~)
            num = 1;
        end

        function num = getNumOutputsImpl(~)
            num = 1;
        end

        function entityType = getEntityTypeImpl(obj)
            entityType = obj.entityType('Car');
        end

        function [inputTypes,outputTypes] = getEntityPortsImpl(obj)
            inputTypes = {'Car'};
            outputTypes = {'Car'};
        end

        function [storageSpecs, I, O] = getEntityStorageImpl(obj)
            storageSpecs = obj.queueFIFO('Car', obj.Capacity);
            I = 1;
            O = 1;
        end

        function name = getSimulinkFunctionNamesImpl(obj)
            name = {'assignData'};
        end
    end
end
```

```

methods

function [entity,event] = CarEntry(obj,storage,entity,source)
    % Specify event actions when entity enters the storage.
    entity.Attribute1 = assignData();
    coder.extrinsic('fprintf');
    fprintf('Entity Attribute Value: %f\n', entity.Attribute1);

    event = obj.eventForward('output', 1, obj.Delay);

end

end

end
end

```

Modify Entity Attributes

- 1 Define the name of the Simulink function to be called in the discrete-event System object using the `getSimulinkFunctionNamesImpl` method.

```

function name = getSimulinkFunctionNamesImpl(obj)
    % Declare the name of the Simulink Function.
    name = {'assignData'};
end

```

The name of the Simulink function is declared as `assignData`.

- 2 Call `assignData` in the entry event action.

```

function [entity,event] = CarEntry(obj,storage,entity,source)
    % Assign data when an entity enters the storage.
    entity.Attribute1 = assignData();
    coder.extrinsic('fprintf');
    fprintf('Entity Attribute Value: %f\n', entity.Attribute1);

    event = obj.eventForward('output', 1, obj.Delay);

end

```

Build the Model

- 1 Create a model using an Entity Generator block, MATLAB Discrete-Event System block, and an Entity Terminator block.
- 2 Open the MATLAB Discrete-Event System block, and set the **Discrete-event System object name** to `CustomEntityStorageBlockSLFunc`.

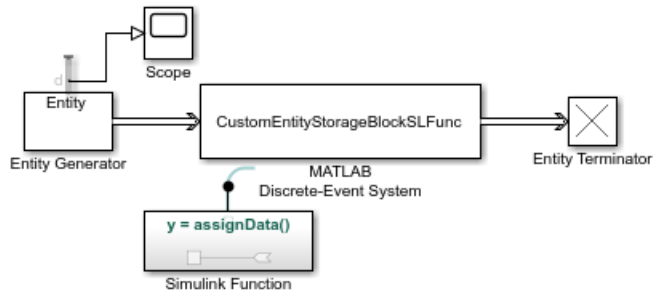

- 3 Output the **Number of entities departed, d** statistic from the Entity Generator block and connect it to a scope.
- 4 Add a Simulink Function block to your model.
 - a On the Simulink Function block, double-click the function signature and enter `y = assignData()`.

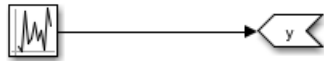

- b In the Simulink Function block, add a Uniform Random Number block and change its **Sample time** parameter to -1.
- 5 Simulate the model. The scope displays 3 entities departed the Entity Generator block.

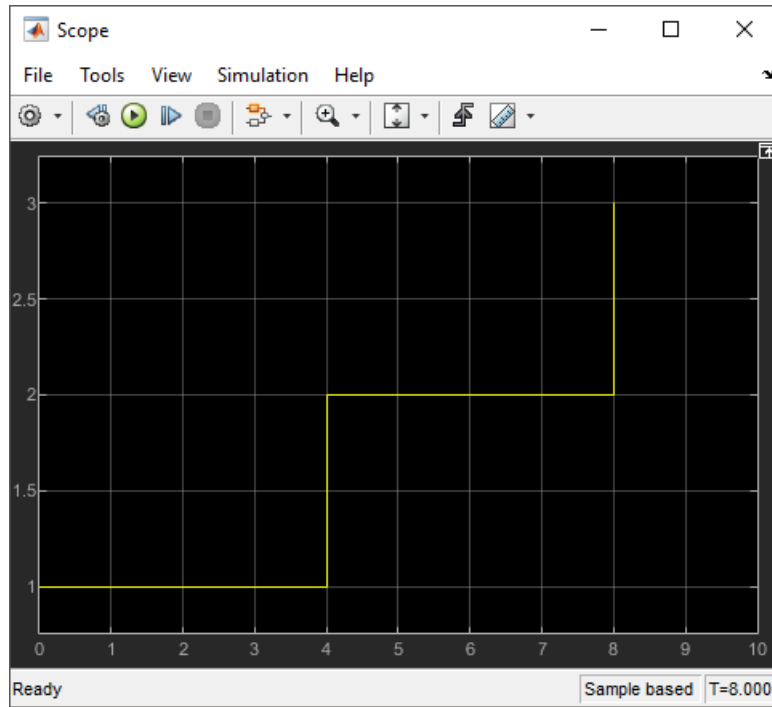

- 6 The Diagnostic Viewer displays the random attribute values assigned to 3 entities when they enter the storage.

```
Entity Attribute Value: -0.562082  
Entity Attribute Value: -0.905911  
Entity Attribute Value: 0.357729
```

See Also

[entry](#) | [getEntityPortsImpl](#) | [getEntityStorageImpl](#) | [getEntityTypesImpl](#) | [matlab.DiscreteEventSystem](#) | [matlab.System](#)

More About

- “Delay Entities with a Custom Entity Storage Block” on page 9-11
- “Create a Custom Entity Storage Block with Iteration Event” on page 9-17

- “Create a Discrete-Event System Object” on page 9-58
- “Generate Code for MATLAB Discrete-Event System Blocks” on page 9-65

Resource Scheduling Using MATLAB Discrete-Event System and Data Store Memory Blocks

This example shows how to model resource scheduling using data exchange between the MATLAB Discrete-Event System block and the Data Store Memory block.

The example models a facility that generates two types of parts, Part A and Part B, that undergo a heating process. Both parts acquire resources for the heating process from the same resource pool. The resource acquisition for Part A has a higher priority. When Part A acquires a certain number of resources, Part B can acquire only 1 resource. This constraint requires that the total number of resources be shared between the processes and the acquisition scheduled based on the shared data.

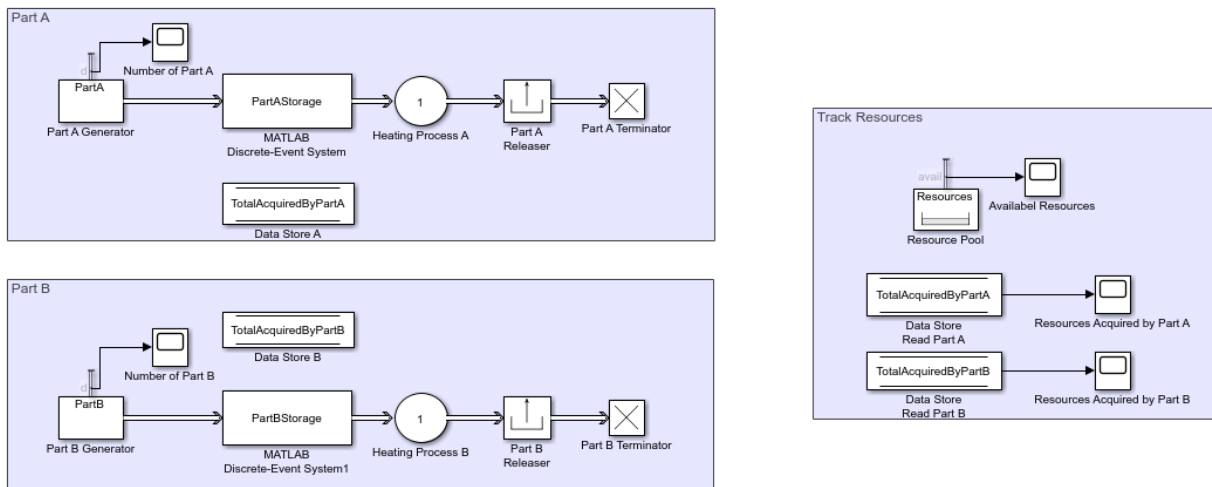

Copyright 2019 The MathWorks, Inc.

Model Description

In the model, an Entity Generator Block generates entities of type PartA. The parts are then sent to a storage unit to acquire resources from the Resource Pool block. A MATLAB Discrete-Event System Block that uses the PartAStorage System Object™ represents the storage unit.

The System Object™ defines the amount of acquired resources and the resource acquisition event for Part A.

```

function [entity,event] = PartAEntry(obj,storage,entity,source)
    % Define the amount of acquired resources as a random value.
    Amount = randi([1 3]);
    resReq = obj.resourceSpecification('Resources', Amount);
    % Define the resource acquisition event.
    event = obj.eventAcquireResource(resReq, 'ResourceAcq');
end

```

When Part A acquires the resources successfully, the entity is forwarded to the output. TotalAcquiredByPartA is the data stored in the Data Store memory block representing the total number of acquired resources by Part A. The System Object™ first calls the value stored in Data Store A. It updates and writes the new TotalAcquiredByPartA value by adding the number of acquired resources.

```

function [entity,events] = resourceAcquired(obj, storage,...
    entity, resources, tag)
    global TotalAcquiredByPartA;
    % After successful resource acquisition, forward the entity
    % to the output |1|.
    events = obj.eventForward('output', 1, obj.Delay);
    % Update the total number of resources acquired.
    TotalAcquiredByPartA = TotalAcquiredByPartA + resources.amount;
end

```

The part is sent to Heating Process A, which is represented by an Entity Server block. When the heating process is complete, the parts release the acquired resources and depart the facility.

In the model, another Entity Generator block generates entities of type Part B. The parts are then sent to a storage unit to acquire resources from the Resource Pool block. A MATLAB Discrete-Event System Block that uses the PartBStorage System Object™ represents the other storage unit.

The System Object™ defines the amount of acquired resources and the resource acquisition event for Part B.

```

function [entity,event] = PartBEntry(obj,storage,entity,source)
    global TotalAcquiredByPartA;
    % If the number of resources acquired by Part A is greater than
    % 30 then Part B acquires only |1| resource.
    if TotalAcquiredByPartA > 30
        Amount = 1;
    else
        % Otherwise, Part B can acquire any number of resources between

```

```

    % |1| and |5|.
    Amount = randi([1 5]);
    end
    resReq = obj.resourceSpecification('Resources', Amount);
    % Define the resource acquisition event.
    event = obj.eventAcquireResource(resReq, 'ResourceAcq');
end

```

The amount of resources Part B acquires depends on the resources acquired by Part A. This acquisition is achieved by PartBStorage System Object™ that reads the value of TotalAcquiredByPartA stored in Data Store A for each entity entry.

After successfully acquiring the resources, the entity is forwarded to the output. The System Object (TM) updates TotalAcquiredByPartB and writes its new value to Data Store B.

```

function [entity,events] = resourceAcquired(obj, storage,...
    entity, resources, tag)
    global TotalAcquiredByPartB; % After succesful resource
    acquisition, forward the entity to the output. events =
    obj.eventForward('output', 1, obj.Delay); % Update the total number
    of resources acquired. TotalAcquiredByPartB = TotalAcquiredByPartB
    + resources.amount;
end

```

Then the parts are sent to Heating Process B. They release the resources after the process is complete and depart the facility.

Track Resources component in the model, tracks available resources and acquired number of resources by each part. Available resources are measured by the **Amount available, avail** statistic from the Resource Pool block. Resources acquired by Part A and Part B is observed by the output of the Data Store Read blocks that read values from Data Store A and Data Store B.

Simulation Results

Simulate the model. Observe the Scope block connected to the Data Store Read Part A. The scope shows that Part A acquires 30 resources around the simulation time 40.

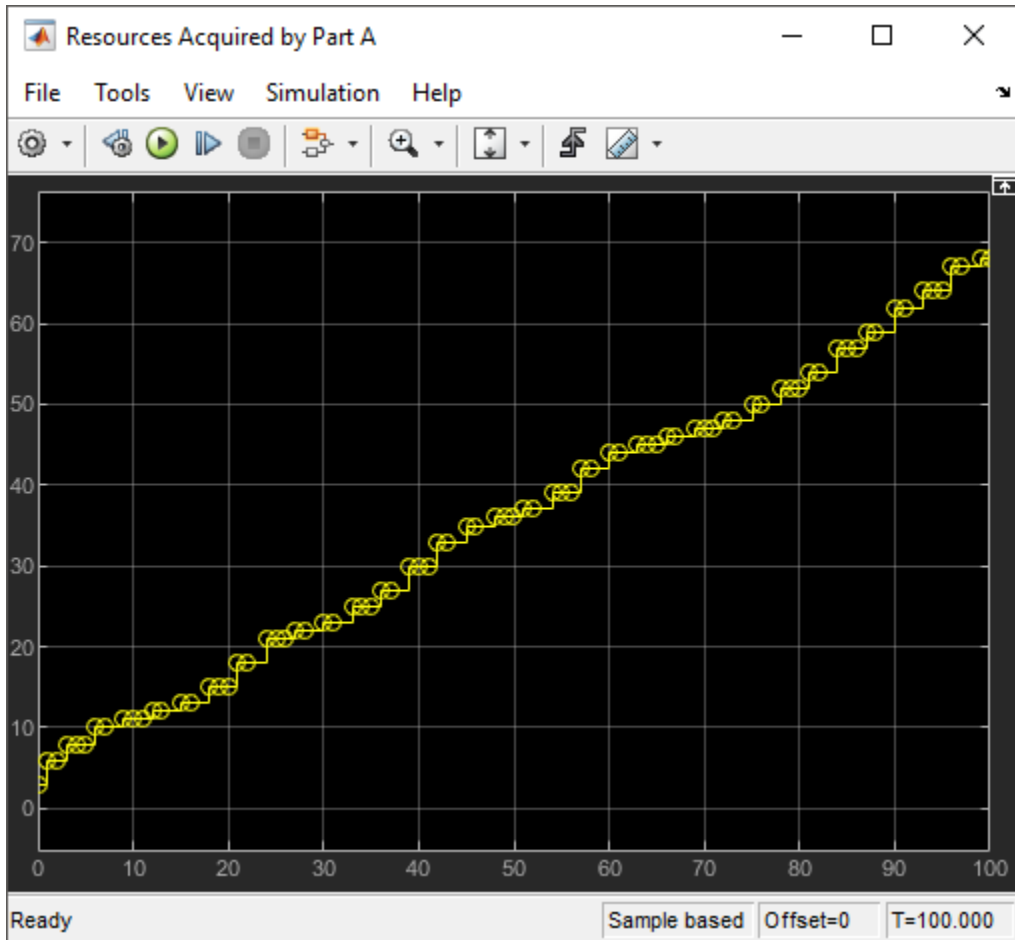

Also observe the Scope block connected to Data Store Read Part B. The scope shows that Part B acquires 1 resource after the simulation time 40 due to the prioritization of resources.

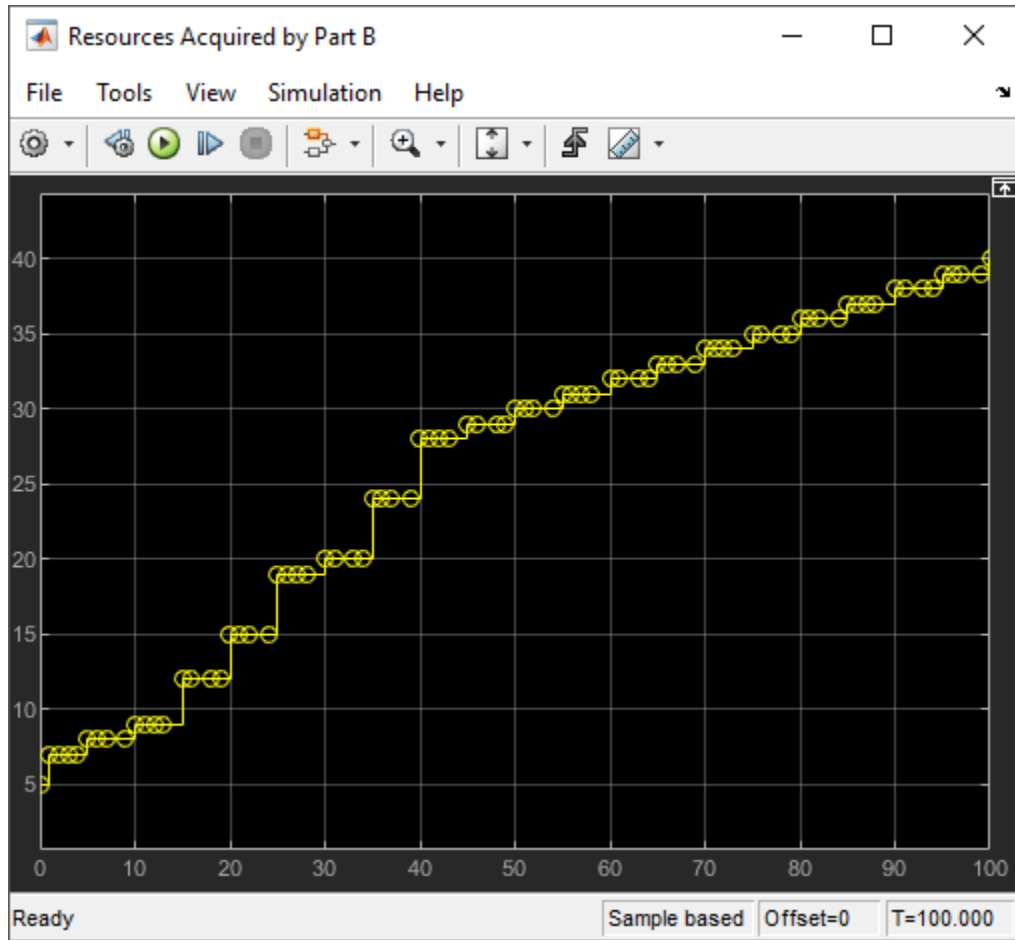

See Also

More About

- “Call Simulink Function from a MATLAB Discrete-Event System Block” on page 9-75
- “Delay Entities with a Custom Entity Storage Block” on page 9-11
- “Create a Custom Entity Storage Block with Iteration Event” on page 9-17

- “Create a Discrete-Event System Object” on page 9-58

Custom Visualization

- “Use SimulationObserver Class to Monitor a SimEvents Model” on page 10-2
- “Custom Visualization Example” on page 10-6
- “Observe Entities Using simevents.SimulationObserver Class” on page 10-8

Use SimulationObserver Class to Monitor a SimEvents Model

In this section...
“SimulationObserver Class” on page 10-2
“Custom Visualization Workflow” on page 10-2
“Create an Application” on page 10-3
“Use the Observer to Monitor the Model” on page 10-5
“Stop Simulation and Disconnect the Model” on page 10-5

SimulationObserver Class

To create an observer, create a class that derives from the `simevents.SimulationObserver` object. You can use observers to:

- Help understand queue impact, visualize entities moving through the model during simulation,
- Develop presentation tools showing model simulation via an application-oriented interface, such as restaurant queue activity.
- Debug and examine entity activity.
- Examine queue contents.

The `simevents.SimulationObserver` object provides methods that let you:

- Create observer or animation objects.
- Identify model blocks for notification of run-time events.
- Interact with the event calendar.
- Perform activities when a model pauses, continues after pausing, and terminates.

SimEvents models call these functions during model simulation.

Custom Visualization Workflow

- 1 Create an application file.

- a Define a class that inherits from the `simevents.SimulationObserver` class.
 - b Create an observer object that derives from this class.
 - c From the `simevents.SimulationObserver` methods, implement the functions you want for your application. This application comprises your observer.
- 2 Open the model.
 - 3 Create an instance of your class.
 - 4 Run the model.

For more information about custom visualization, see “Create Custom Visualization”.

Create an Application

You can use these methods in your derived class implementation of `simevents.SimulationObserver`.

Action	Method
Specify behavior when simulation starts.	<code>simStarted</code>
Specify behavior when simulation pauses.	<code>simPaused</code>
Specify behavior when simulation resumes.	<code>simResumed</code>
Define observer behavior when simulation is terminating.	<code>simTerminating</code>
Specify list of blocks to be notified of entity entry and exit events.	<code>getBlocksToNotify</code>
Specify whether you want notification for all events in the event calendar.	<code>notifyEventCalendarEvents</code>
Specify behavior after an entity enters a block that has entity storage.	<code>postEntry</code>
Specify behavior before an entity exits a block with entity storage.	<code>preExit</code>

Action	Method
Specify behavior before execution of an event.	preExecute
Add block to list of blocks to be notified.	addBlockNotification
Remove block from list of blocks being notified.	removeBlockNotification
Get handles to event calendars.	getEventCalendars
Get list of blocks that store entities.	getAllBlockWithStorages
Return block handle for a given block path.	getHandleToBlock
Return storage handles of specified block.	getHandlesToBlockStorages

- 1 In the MATLAB Command Window, select **New > Class**.
- 2 In the first line of the file, inherit from the `simevents.SimulationObserver` class. For example:

```
classdef seExampleRestaurantAnimator < simevents.SimulationObserver
```

`seExampleRestaurantAnimator` is the name of the new observer object.

- 3 In the `properties` section, enter the properties for your application.
- 4 In the `methods` section, implement the functions for your application.
- 5 To construct the observer object, enter a line like the following in the `methods` section of the file:

```
function this = seExampleRestaurantAnimator
    % Constructor
    modelname = 'seExampleCustomVisualization';
    this@simevents.SimulationObserver(modelname);
    this.mModel = modelname;
end
```

The `matlabroot\toolbox\simevents\examples` folder contains this application example, `seExampleRestaurantAnimator.m`. This example uses an observer object to implement an animator for the `seExampleCustomVisualization` model.

For more information, see **Using Custom Visualization for Entities** in the SimEvents **Examples** tab.

Use the Observer to Monitor the Model

- 1 Open the model to observe.
- 2 At the MATLAB command prompt, to enable the animator for the model:

```
>> obj=seExampleRestaurantAnimator;
```

- 3 Simulate the model.

When the model starts, the animator is displayed in a figure window. As the model runs, it makes calls into your application to see if you have implemented one of the predefined set of functions. If your model does not contain a SimEvents block, you receive an error.

Note As a result of the instrumentation to visualize the simulation, the simulation is slower than without the instrumentation.

Stop Simulation and Disconnect the Model

- 1 Stop the simulation.
- 2 At the MATLAB command prompt, clear the animator from the model. For example:

```
clear obj;
```

See Also

simevents.SimulationObserver

Related Examples

- “Observe Entities Using simevents.SimulationObserver Class” on page 10-8
- “Custom Visualization Example” on page 10-6
- “Visualization and Animation for Debugging” on page 5-14

Custom Visualization Example

In this section...
“Structure of Example Model” on page 10-6
“Visualize Entities” on page 10-6

The `Using Custom Visualization for Entities` example visualizes a restaurant layout with customer entities entering, dining, and leaving. It uses `seExampleCustomVisualization` to model a restaurant. To observe the visualization, start the model and the animator.

Structure of Example Model

The `seExampleCustomVisualization` model has these major components:

- The Entity Generator block (Patron Enter) generates entities representing customer entities. Each customer has a *TimeToDine* amount of time to dine.
- These customer entities enter a waiting area, where a Resource Acquirer block acquires a table for the customer.
- The Resource Pool block contains 10 table resources.
- When a table entity is available for a waiting customer entity, the Entity Server block serves the customer for a *TimeToDine* amount of time.
- When a customer entity is done dining, the Resource Releaser block releases the table resource back to the resource pool.
- The customer entity leaves the restaurant through the Entity Terminator block (Patron Leave).

Visualize Entities

The `seExampleRestaurantAnimator` application animates the diners entering, dining, and leaving the restaurant. The animator application draws a different colored dot for each customer. As customers move through the restaurant, the application animates the motion of the dots.

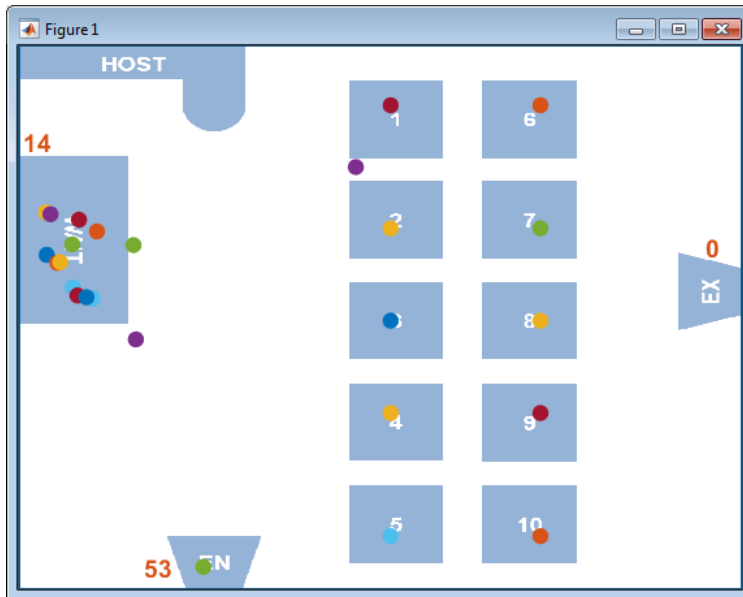

See Also

`simevents.SimulationObserver`

More About

- “Observe Entities Using `simevents.SimulationObserver` Class” on page 10-8
- “Use `SimulationObserver` Class to Monitor a `SimEvents` Model” on page 10-2
- “Access Property Values” (MATLAB)
- “Visualization and Animation for Debugging” on page 5-14

Observe Entities Using `simevents.SimulationObserver` Class

This example shows how to use `simevents.SimulationObserver` object to count entity departures and acquire departure timestamps.

Use the `simevents.SimulationObserver` object to observe or visualize entities, and implement animators to debug model simulations. For more information, see “Use `SimulationObserver` Class to Monitor a SimEvents Model” on page 10-2.

In this model, the `simevents.SimulationObserver` object is used to acquire the number of entities departing a block or a set of blocks in the model and timestamp their departures. The model has two Entity Generator and Entity Terminator blocks and an Entity Server Block. The Scope blocks display the **Number of entities departed, d** statistics for the Entity Generator and Entity Server blocks.

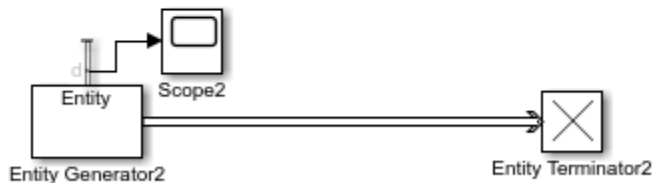
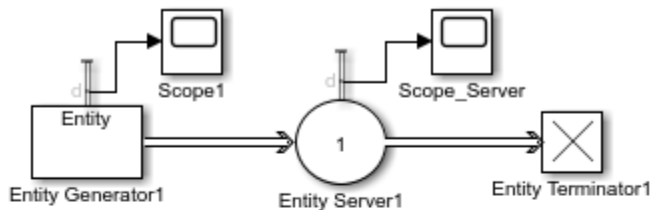

Copyright 2019 The MathWorks, Inc.

Create the Observer

Open a new script and initiate the `simevents.SimulationObserver` object by this code.

```
classdef myObserverPreexit < simevents.SimulationObserver
    % Add the observer properties.
    properties
        Model
    % Initialize the property count.
        count
    end

    properties (Constant, Access=private)
        increment = 1;
    end

    methods

        % Observe any model by incorporating its name to MyObserverPreexit.
        function this = myObserverPreexit(Model)
            % Input model name to the simulation observer.
            this@simevents.SimulationObserver(Model);
            this.Model = Model;
        end

        % Initialize the count in the simulation start.
        function simStarted(this)
            this.count = 0;
        end

        % Specify list of blocks to be notified of entity entry and exit
        % events.
        function Block = getBlocksToNotify(this)
            Block = this.getAllBlockWithStorages();
        end

        function preExit(this,evSrc,Data)
            % Get the names of all storage blocks that the entities depart.
            % This returns the block with its path.
            Block = Data.Block.BlockPath;
            % Remove the path to display only the
            % block name.
            Block = regexp(Block,'ObserverPreexitModel/' , '');
            % Initialize the blocks to observe.
            BlockName = 'Entity Server';
            % If the block that entity exits contains the block name
            % acquire data for exit time and block name.
            if contains(Block, BlockName)
                % Get time for entity preexit from event calendar.
                evCal = this.getEventCalendars;
```

```
        Time = evCal(1).TimeNow;
        % Increase the count for departing entities.
        this.count = this.count + this.increment;

        myInfo = [' At time ', num2str(Time), ...
                  ' an entity departs ', Block, ', Total entity count is ', ...
                  num2str(this.count)];
        disp(myInfo);
    end
end
end
```

Save the file as `myObserverPreexit.m` file.

Monitor the Model

Enable the observer object to monitor `ObserverPreexitModel` model.

```
obj = myObserverPreexit('ObserverPreexitModel');
```

The observer monitors the Entity Server block, which is determined by the `BlockName` parameter in the observer file `myObserverPreexit.m`.

- Simulate the model. Click **View Diagnostics** on the model window and observe that the number of entities departing the Entity Server block and the departure timestamps.

```
At time 3 an entity departs Entity Server1, Total entity count is 1
At time 6 an entity departs Entity Server1, Total entity count is 2
At time 9 an entity departs Entity Server1, Total entity count is 3
```

- For validation, observe the Scope block that displays the **Number of entities departed, d** statistic for the Entity Server block.

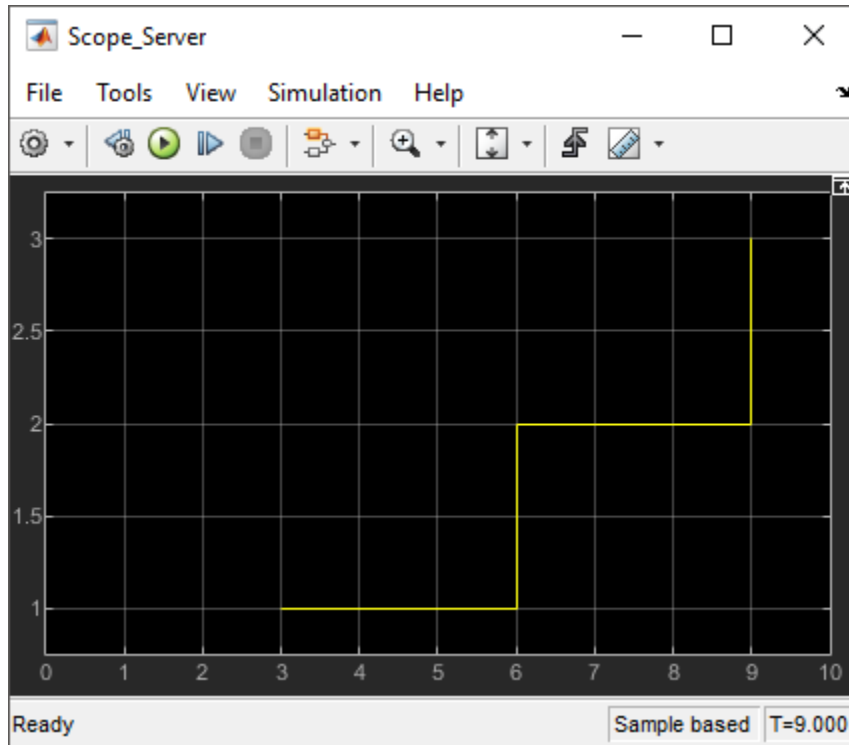

Monitor Multiple Blocks in the Model

Use the same observer to monitor the entity departures from all of the Entity Generator blocks in your model.

- Change the BlockName parameter in the preExit method to 'Entity Generator'. Entity Generator blocks in the model are labeled Entity Generator1 and Entity Generator2.

```
function preExit(this,evSrc,Data)
    % Get the names of all storage blocks that the entities depart.
    % returns the block with its path.
    Block = Data.Block.BlockPath;
    % Remove the path to display only the block name
    Block = regexprep(Block,'ObserverPreexitModel/' , '');
    % Initialize the common Entity Generator phrase
    BlockName = 'Entity Generator';
```

```

% If the block that the entity exits contains the block name
% acquire the exit time and the block name.
if contains(Block, BlockName)
    % Get the time of entity preexit from the event calendar.
    evCal = this.getEventCalendars;
    Time = evCal(1).TimeNow;
    % Increase the count of departing entities.
    this.count = this.count + this.increment;

    myInfo = [' At time ', num2str(Time), ...
              ' an entity departs ', Block, ', Total entity count is ', ...
              num2str(this.count)];
    disp(myInfo);
end
end

```

- Enable the observer object to monitor ObserverPreexitModel model.

```
obj = myObserverPreexit('ObserverPreexitModel');
```

- Simulate the model. Observe the Diagnostic Viewer that displays the information for 15 entities departing from both Entity Generator blocks.

```

At time 0 an entity departs Entity Generator1, Total entity count is 1
At time 0 an entity departs Entity Generator2, Total entity count is 2
At time 1 an entity departs Entity Generator2, Total entity count is 3
At time 2 an entity departs Entity Generator2, Total entity count is 4
At time 3 an entity departs Entity Generator1, Total entity count is 5
At time 3 an entity departs Entity Generator2, Total entity count is 6
At time 4 an entity departs Entity Generator2, Total entity count is 7
At time 5 an entity departs Entity Generator2, Total entity count is 8
At time 6 an entity departs Entity Generator1, Total entity count is 9
At time 6 an entity departs Entity Generator2, Total entity count is 10
At time 7 an entity departs Entity Generator2, Total entity count is 11
At time 8 an entity departs Entity Generator2, Total entity count is 12
At time 9 an entity departs Entity Generator1, Total entity count is 13
At time 9 an entity departs Entity Generator2, Total entity count is 14
At time 10 an entity departs Entity Generator2, Total entity count is 15

```

- For validation, observe Scope1 and Scope2 blocks display the **Number of entities departed, d** statistic for the Entity Generator1 and the Entity Generator2.

Observe that 4 entities depart Entity Generator1.

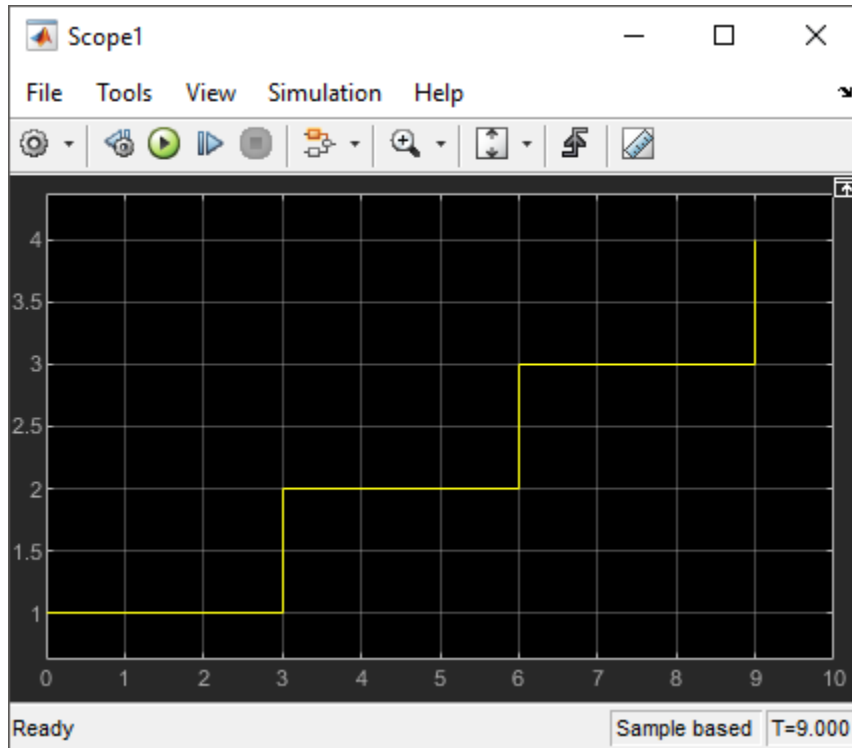

Also, 11 entities depart Entity Generator2. In total, 15 entities departed from the Entity Generator blocks in the model.

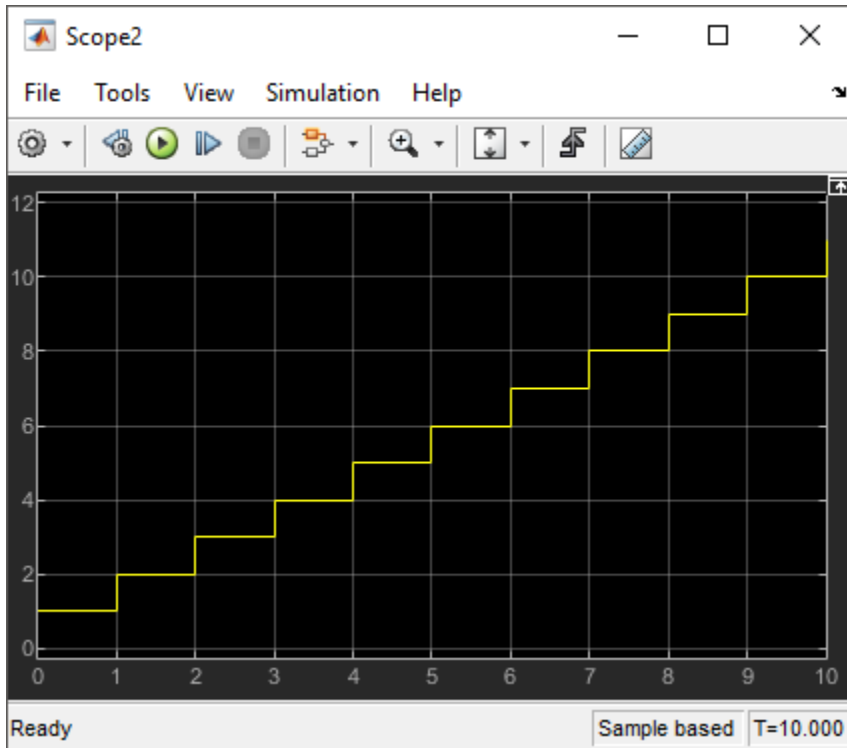

See Also

`getBlocksToNotify` | `getEventCalendars` | `preExit` | `simStarted` | `simevents.SimulationObserver`

More About

- “Use SimulationObserver Class to Monitor a SimEvents Model” on page 10-2
- “Visualization and Animation for Debugging” on page 5-14
- “Custom Visualization Example” on page 10-6

Migrating SimEvents Models

Migration Considerations

To take advantage of SimEvents features, migrate legacy SimEvents models (pre-R2016a). Benefits include:

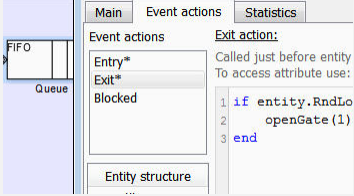
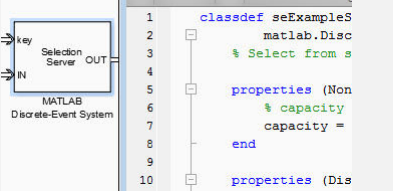
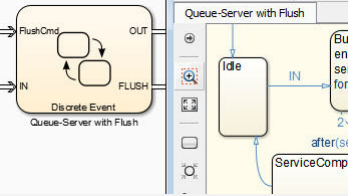
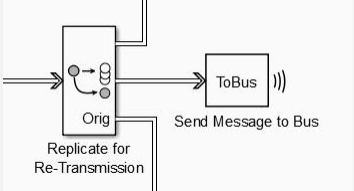
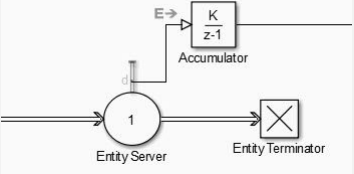
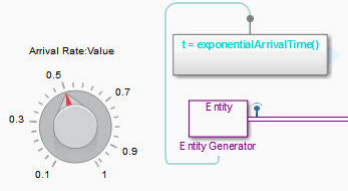
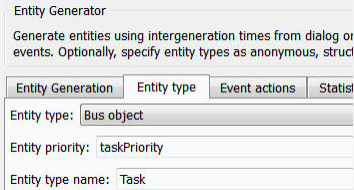
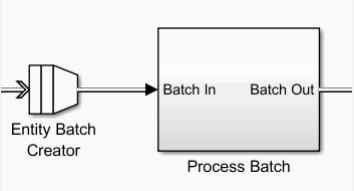
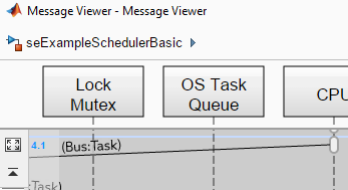
<p>Event actions</p> 	<p>MATLAB Discrete-Event System block</p> 	<p>Discrete-Event Chart block</p> 
<p>Entity multicast</p> 	<p>Domain transitions</p> 	<p>Simulink integration</p> 
<p>Unified entity type</p> 	<p>Entity Batch Creator and Splitter blocks</p> 	<p>Sequence Viewer</p> 

Use SimEvents software to:

- Modify entity attributes, service, and routes on events such as entity generation, entry, and exit.
- Create custom SimEvents blocks using MATLAB.

- Create Stateflow state transition diagrams that process entities, react to entity events, and follow precise timing for temporal operations.
- Wirelessly broadcast copies of entities to multiple receive queues.
- Automatically switch between time-based and event-based signals.
- Use Simulink features, such as Fast Restart to speed up simulation runs and Simulation Stepper to debug.
- Define entity types that are consistent across Simulink, Stateflow, and SimEvents products.
- Create and split batch of entities.
- Display interchange of messages and entities.

When You Should Not Migrate

If your legacy model contains timeout blocks, do not migrate the model. You can still access legacy blocks to continue developing older models by using the blocks in the Legacy Block Library.

See Also

More About

- “Migration Workflow” on page 11-4
- “Identify and Redefine Entity Types” on page 11-7
- “Replace Old Blocks” on page 11-9
- “Connect Signal Ports” on page 11-13
- “Write Event Actions for Legacy Models” on page 11-19
- “Observe Output” on page 11-29
- “Reactive Ports” on page 11-31

Migration Workflow

This migration workflow helps you migrate legacy SimEvents models to R2016a or later. In this workflow, you create a new SimEvents model to replace your legacy SimEvents model. This is an iterative workflow that requires you to repeat some steps.

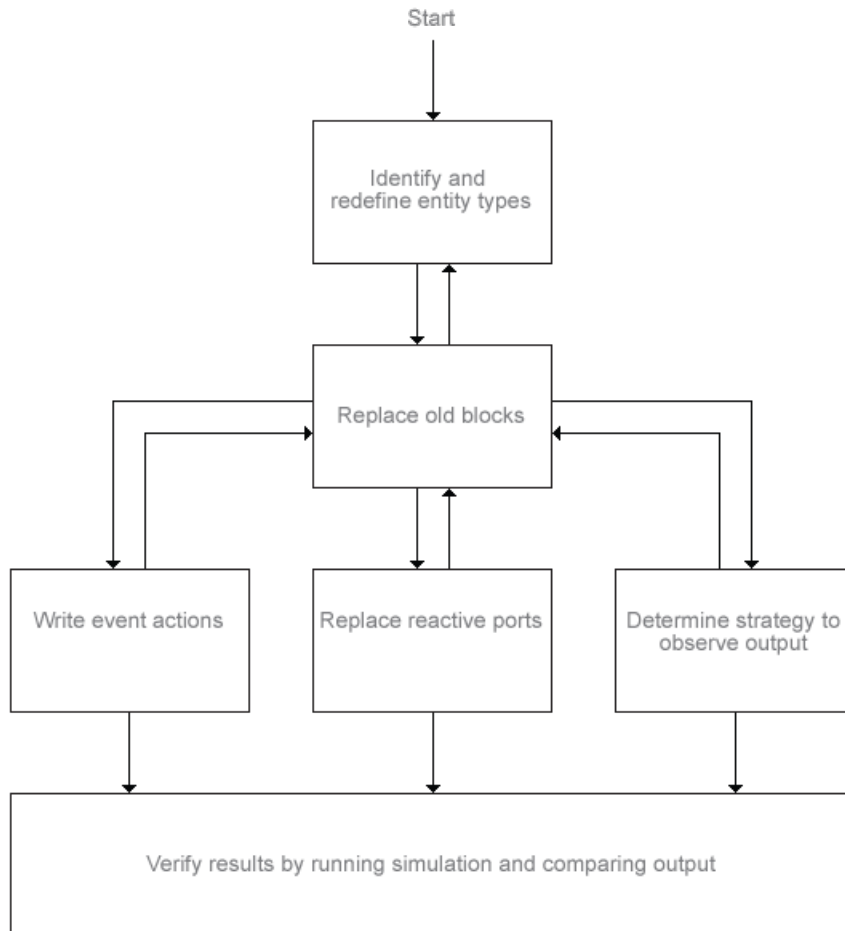

- 1 Before you start, copy your legacy model to a backup folder. Run the old model and collect the results using the Simulation Data Inspector (“Inspect Simulation Data” (Simulink)).

Note Pre-R2016a SimEvents blocks cannot coexist in a model with post-R2016a SimEvents blocks.

- 2 Identify and redefine entity types (“Identify and Redefine Entity Types” on page 11-7)
- 3 When possible, replace old blocks with new blocks (“Replace Old Blocks” on page 11-9) and reconfigure the new blocks.
- 4 Write event actions for these instances:
 - a Replace Set Attribute blocks with event actions in other blocks (“Replace Set Attribute Blocks with Event Actions” on page 11-19)
 - b Replace Get Attribute blocks with event actions in other blocks (“Connect Signal Ports” on page 11-13)
 - c Replace Attribute Function blocks with event actions in other blocks (“Replace Attribute Function Blocks with Event Actions” on page 11-23)
 - d Replace random number generators with event actions in other blocks (“Replace Random Number Distributions in Event Actions” on page 11-21)
- 5 Replace reactive ports (see “If Connected to Reactive Ports” on page 11-16).
- 6 Determine a strategy to observe output by replacing Discrete Event Signal to Workspace blocks with To Workspace blocks or logging (“Observe Output” on page 11-29).
- 7 Verify the results by running the simulation and using Simulation Data Inspector to compare these results with those you collect in step 1.

See Also

More About

- “Migration Considerations” on page 11-2
- “Identify and Redefine Entity Types” on page 11-7
- “Replace Old Blocks” on page 11-9
- “Connect Signal Ports” on page 11-13
- “Write Event Actions for Legacy Models” on page 11-19
- “Observe Output” on page 11-29

- “Reactive Ports” on page 11-31

Identify and Redefine Entity Types

Identify entity types in the legacy model and redefine them in the new model.

- 1 In the old model, identify all Entity Generator blocks that feed each Entity Sink block.
- 2 In the model, from the **Display** menu, select **Signals & Ports > Port Data Types**.
- 3 To see the attributes at each Entity Generator, Entity Sink, or other termination points of entity flow, hover over the entity label to display attribute associated with the entity. A popup window displays the attributes associated with the port.

Repeat this step for each block and note the attributes.

- 4 In the new model, add Entity Generator blocks to replace those in the legacy model.
- 5 In the model, in the Entity Generator block **Entity type** tab, define the entity type for each block with the full list of attributes for that block (found in step 3).

This example shows the redefined attributes,

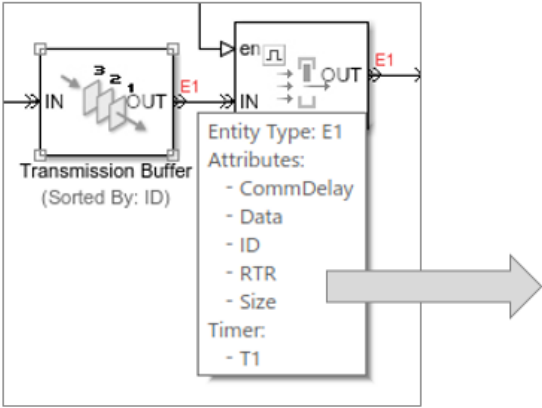

The diagram illustrates the process of identifying and redefining entity types. On the left, a 'Transmission Buffer (Sorted By: ID)' block is shown with an 'IN' port and an 'OUT' port. A popup window displays the 'Entity Type: E1' with the following attributes: - CommDelay, - Data, - ID, - RTR, - Size, and Timer: - T1. A large grey arrow points from this popup to the 'Entity Generator' configuration window on the right.

The 'Entity Generator' window is titled 'Entity Generator' and has four tabs: 'Entity Generation', 'Entity type', 'Event actions', and 'Statistics'. The 'Entity type' tab is selected, showing the following configuration:

- Entity type: Structured
- Entity priority: 300
- Entity type name: CAN_Msg
- Define attributes:

	Attribute Name	Attribute Initial Value
1	CommDelay	1
2	Data	1
3	ID	1
4	RTR	1
5	Size	1
6	Timer_T1	1

Once you define the entity types, return to “Migration Workflow” on page 11-4.

See Also

More About

- “Migration Considerations” on page 11-2
- “Migration Workflow” on page 11-4
- “Replace Old Blocks” on page 11-9
- “Connect Signal Ports” on page 11-13
- “Write Event Actions for Legacy Models” on page 11-19
- “Observe Output” on page 11-29
- “Reactive Ports” on page 11-31

Replace Old Blocks

The primary goal in migration is to replace legacy SimEvents behavior with new SimEvents behavior.

This table lists:

- New SimEvents blocks to replace legacy SimEvents blocks
- Actions to take when there is no equivalent new SimEvents block to replace the legacy block. Some of these actions are also part of the migration workflow.

Old Block	Action for New SimEvents Model
Attribute Function	Wait until “Replace Attribute Function Blocks with Event Actions” on page 11-23.
Attribute Scope	Wait until “If Using Get Attribute Blocks to Observe Output” on page 11-13.
Cancel Timeout	Consider not yet migrating your model.
Conn	Simulink Inport or Outport block.
Discrete Event Signal to Workspace	Wait until “Observe Output” on page 11-29.
Enabled Gate	Replace with Entity Gate.
Entity Combiner	Replace with Composite Entity Creator.
Entity Departure Counter	Wait until “Write Event Actions for Legacy Models” on page 11-19.
Entity Departure Function-Call Generator	Wait until “Write Event Actions for Legacy Models” on page 11-19.
Entity Sink	Replace with Entity Terminator.
Entity Splitter	Replace with Composite Entity Splitter.
Entity Departure Function-Call Generator	Wait until “Write Event Actions for Legacy Models” on page 11-19.
Event Filter	Delete (block no longer needed).
Event to Timed Function-Call	Delete (block no longer needed).
Event to Timed Signal	Delete (block no longer needed).

Old Block	Action for New SimEvents Model
Event-Based Entity Generator	Replace with Entity Generator.
Event-Based Random Number	Wait until “Replace Random Number Distributions in Event Actions” on page 11-21.
Event-Based Sequence	Wait until “Write Event Actions for Legacy Models” on page 11-19.
FIFO Queue	Replace with Entity Queue.
Get Attribute	Wait until “Connect Signal Ports” on page 11-13.
Infinite Server	Replace with Entity Server.
Initial Value	Delete (block no longer needed).
Input Switch	Replace with Entity Input Switch.
Instantaneous Entity Counting Scope	Wait until “If Using Get Attribute Blocks to Observe Output” on page 11-13.
Instantaneous Event Counting Scope	Delete (block no longer needed).
LIFO Queue	Replace with Entity Queue.
N-Server	Replace with Entity Server.
Output Switch	Replace with Entity Output Switch.
Path Combiner	Input Switch (with All selected).
Priority Queue	Replace with Entity Queue.
Read Timer	For an example, see “Measure Point-to-Point Delays” on page 1-56.
Release Gate	Replace with Entity Gate.
Replicate	Replace with Entity Replicator.
Resource Acquire	Replace with Resource Acquire.
Resource Pool	Replace with Resource Pool.
Resource Release	Replace with Resource Releaser.
Schedule Timeout	Consider not yet migrating your model.
Set Attribute	Wait until “Replace Set Attribute Blocks with Event Actions” on page 11-19.

Old Block	Action for New SimEvents Model
Signal Latch	Delete (block no longer needed).
Signal Scope	Replace with Simulink Scope.
Signal-Based Function-Call Event Generator	Wait until “If Connected to Reactive Ports” on page 11-16.
Signal-Based Function-Call Generator	Wait until “If Connected to Reactive Ports” on page 11-16.
Single Server	Replace with Entity Server.
Start Timer	For an example, see “Measure Point-to-Point Delays” on page 1-56.
Time-Based Entity Generator	Replace with Entity Generator.
Time-Based function-Call Generator	Replace with Entity Generator.
Timed to Event Function-Call	Delete (block no longer needed).
Timed to Event Signal	Delete (block no longer needed).
X-Y Attribute Scope	See “If Connected to Computation Blocks” on page 11-14.
X-Y Signal Scope	Simulink XY Graph.

When done, return to “Migration Workflow” on page 11-4.

See Also

More About

- “Migration Considerations” on page 11-2
- “Migration Workflow” on page 11-4
- “Identify and Redefine Entity Types” on page 11-7
- “Connect Signal Ports” on page 11-13
- “Write Event Actions for Legacy Models” on page 11-19
- “Observe Output” on page 11-29

- “Reactive Ports” on page 11-31

Connect Signal Ports

Previous releases use Get Attribute blocks to output the values of entity attributes. SimEvents 5.0 is more closely tied to Simulink. This close association lets you use traditional Simulink tools to get attribute values. Replace Get Attribute blocks using these guidelines.

If Connected to Gateway Blocks

SimEvents models no longer require gateway blocks. Remove all gateway blocks, as shown in the figure:

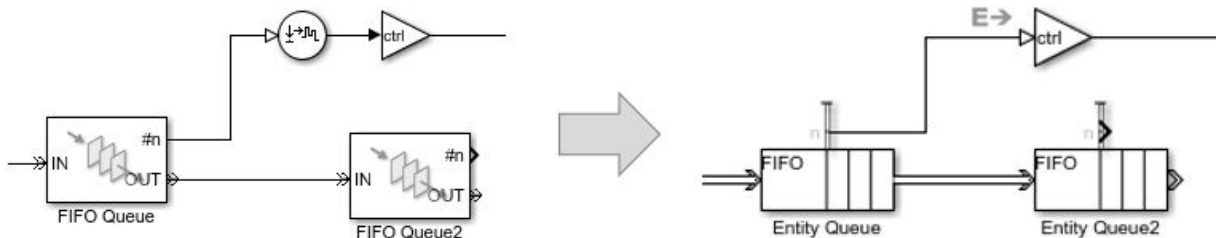

Return to “Connect Signal Ports” on page 11-13.

If Using Get Attribute Blocks to Observe Output

If you use Get Attribute blocks to observe output, see “Observe Output” on page 11-29. For example, you can use the Simulation Data Inspector to visualize entities from an Entity Generator block. This example shows how to visualize entities using the Simulation Data Inspector, logging, and a scope.

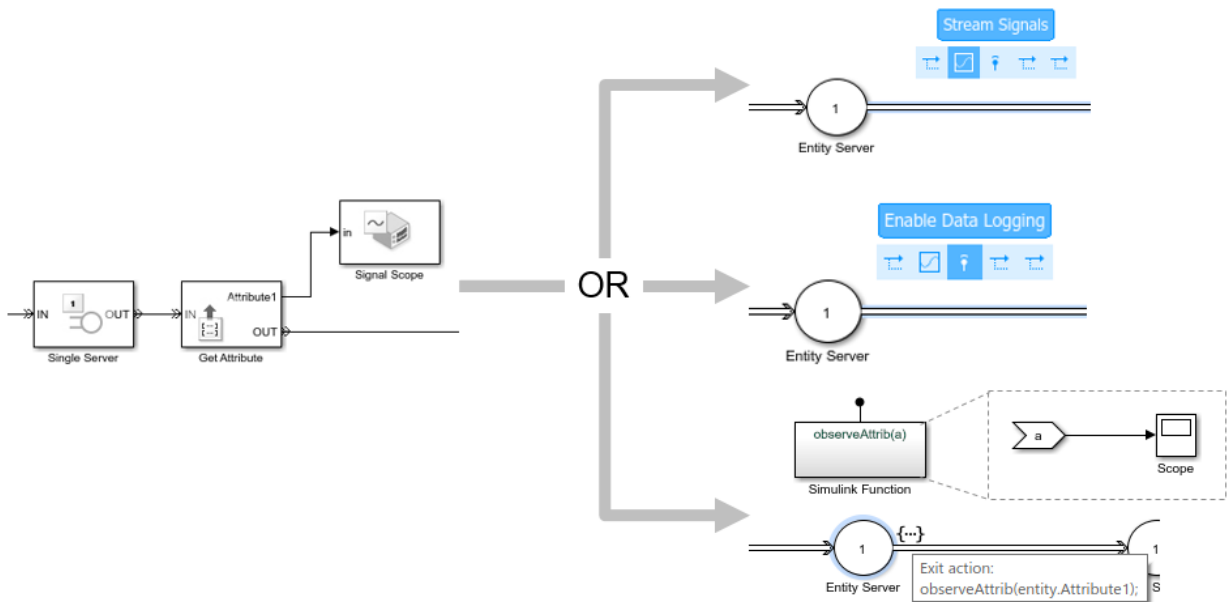

Return to “Connect Signal Ports” on page 11-13.

If Connected to Computation Blocks

If the Get Attribute block is connected to computational blocks, reproduce the behavior of these blocks with Simulink Function blocks.

- 1 Place the computation blocks in a Simulink Function block.
- 2 Call the Simulink Function block from an event action.

This example places the Gain and Bias blocks in the Simulink Function block.

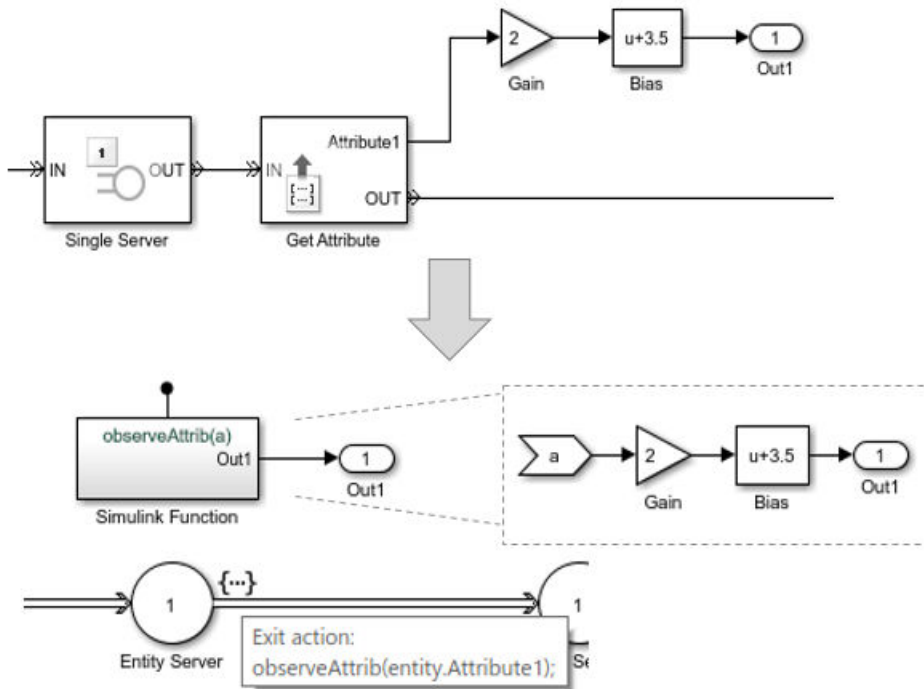

This table shows how each statistics port gets updated.

Statistics Port	Updated on Event			
	Entry	Exit	Blocked	Preempted
Number of entities departed, d		✓		
Number of entities in block, n	✓			
Number of entities arrived, a	✓			
Pending entity present in block, pe		✓	✓	✓

Statistics Port	Updated on Event			
	Entry	Exit	Blocked	Preempted
Number of pending entities, np		✓	✓	✓
Number of entities preempted, p				✓
Average intergeneration time, w				
Average wait, w		✓		✓
Average queue length, l	✓	✓		
Utilization, util	✓	✓		✓

Return to “Connect Signal Ports” on page 11-13.

If Connected to Reactive Ports

In previous releases, reactive ports are signal input ports that listen for updates or changes in the input signal. When the input signal changes, an appropriate reaction occurs in the block possessing the port. Convert all reactive port event signals to messages, as in this example.

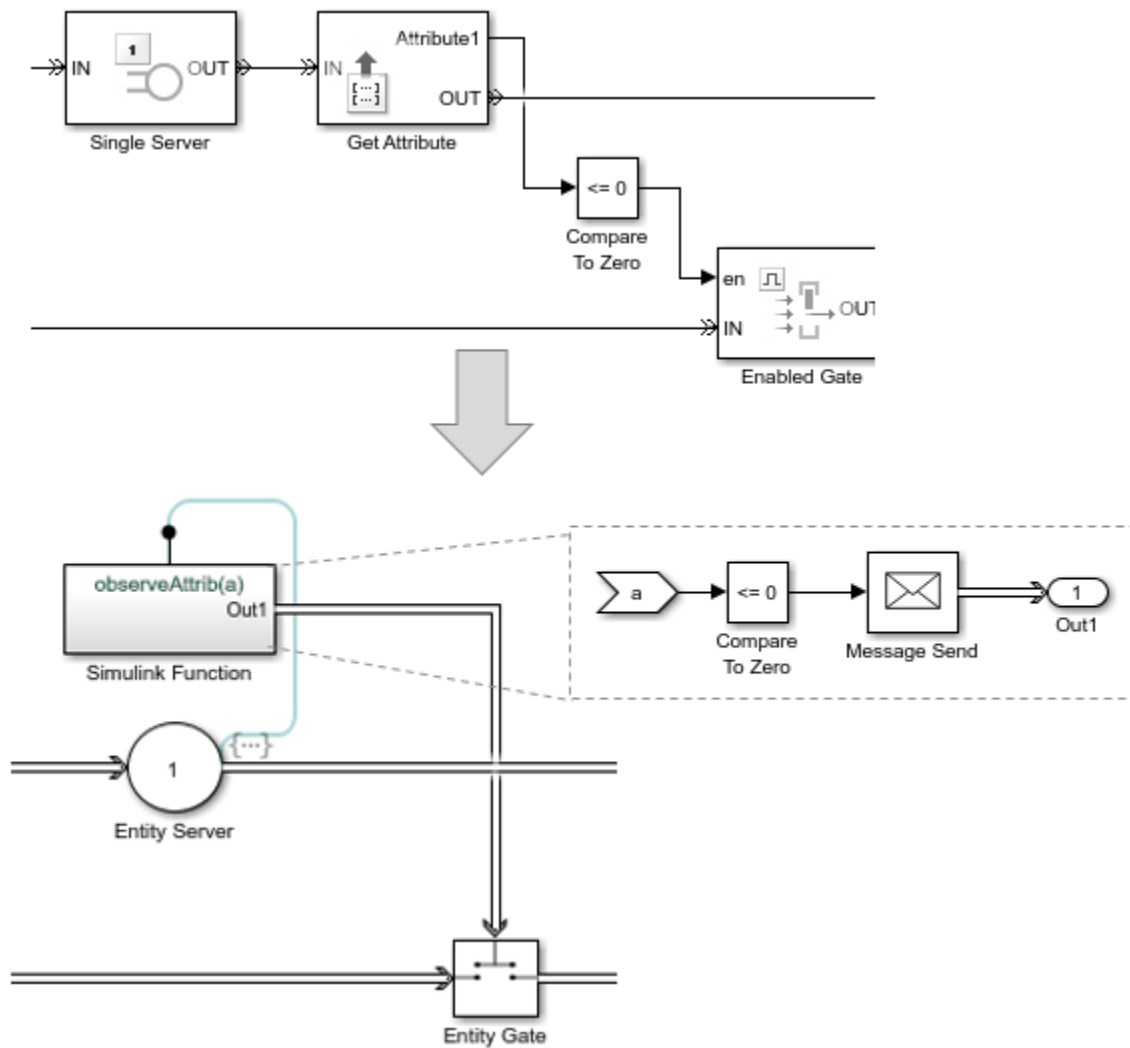

For more information, see “Reactive Ports” on page 11-31.

Return to “Connect Signal Ports” on page 11-13.

See Also

More About

- “Migration Considerations” on page 11-2
- “Migration Workflow” on page 11-4
- “Identify and Redefine Entity Types” on page 11-7
- “Replace Old Blocks” on page 11-9
- “Write Event Actions for Legacy Models” on page 11-19
- “Observe Output” on page 11-29
- “Reactive Ports” on page 11-31

Write Event Actions for Legacy Models

When migrating legacy SimEvents models, you often must create event actions in these instances:

- Setting attribute values
- Getting attribute values
- Generating random number generation
- Using Event sequences
- Replacing Attribute Function blocks
- Using Simulink signals in an event-based computation

Replace Set Attribute Blocks with Event Actions

Use these guidelines to replace Set Attribute blocks:

- If the Set Attribute blocks immediately follow entity generator blocks to initialize attributes, in the Entity Generator block, code the **Generate** action on the **Event actions** tab to set the attribute initial value. For example:

```
entitySys.id=5;
```
- If the Set Attribute blocks change attributes, in the Entity Generator block, code the **Create** action on the **Event actions** tab.

This example illustrates the **Generation** action to initialize the attribute values:

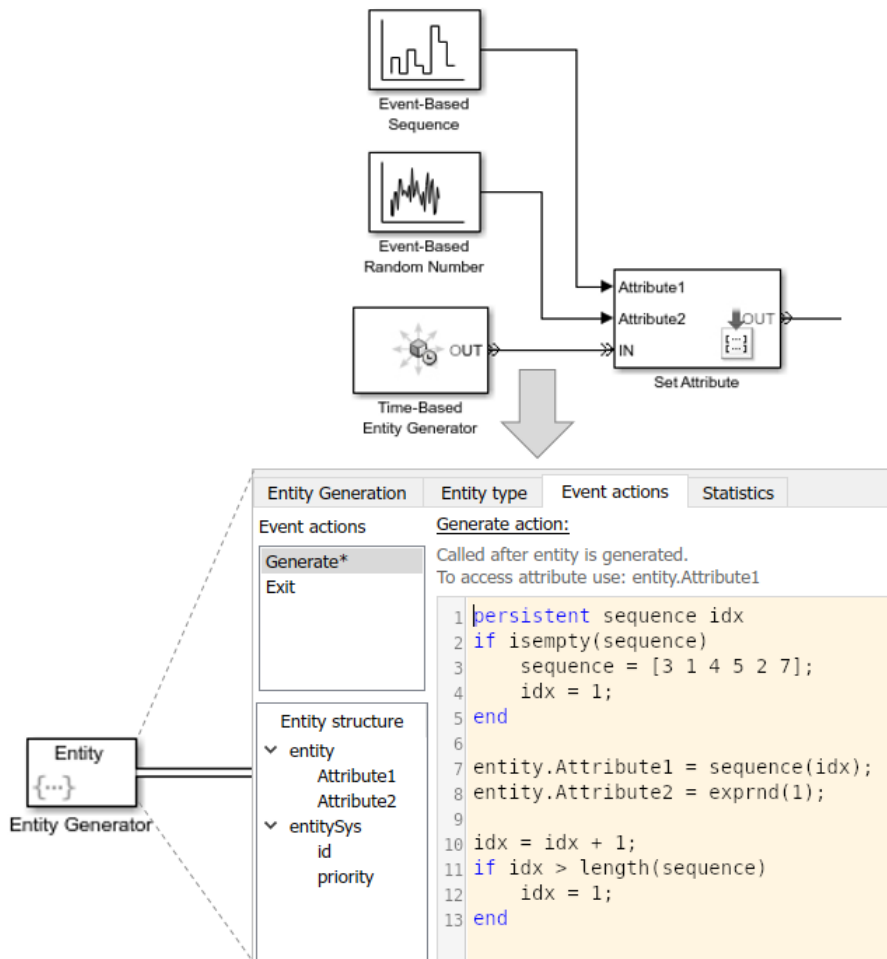

Return to “Migration Workflow” on page 11-4.

Get Attribute Values

If you write event actions to get attribute values, use a Simulink Function block:

- 1 Place the computation block in a Simulink Function block.
- 2 Pass the attribute value as an argument from the event action to the Simulink Function block.

Replace Random Number Distributions in Event Actions

You can generate random numbers using:

- “Random Number Distribution” on page 11-21
- “Example of Arbitrary Discrete Distribution Replacement” on page 11-21

Random Number Distribution

Replace Event-Based Random Number block random number distribution modes with equivalent MATLAB code in event actions. For more information about generating random distributions, see “Event Action Languages and Random Number Generation” on page 1-5.

If you need additional random number distributions, see “Statistics and Machine Learning Toolbox”.

Once you generate random numbers, return to “Migration Workflow” on page 11-4.

Example of Arbitrary Discrete Distribution Replacement

Here is an example of how to reproduce the arbitrary discrete distribution for the Event-Based Random Number legacy block. Assume that the block has these parameter settings:

- **Distribution:** Arbitrary discrete
- **Value vector:** [2 3 4 5 6]
- **Probability vector:** [0.3 0.3 0.1 0.2 0.1]
- **Initial seed:** 12234

As a general guideline:

- 1 Set the initial seed, for example:

```
persistent init
if isempty(init)
    rng(12234);
    init=true;
end
```

- 2 Determine what the value vector is assigned to in the legacy model and directly assign it in the action code in the new model. In this example, the value vector is assigned to the `FinalStop`.

- 3 To assign values within the appropriate range, calculate the cumulative probability vector. For convenience, use the probability vector to calculate the cumulative probability vector. For example, if the probability vector is:

```
[0.3 0.3 0.1 0.2 0.1]
```

The cumulative probability vector is:

```
[0.3 0.6 0.7 0.9 1]
```

- 4 Create a random variable to use in the code, for example:

```
x=rand();
```

Here is example code for this example block to calculate the distribution. The value vector is assigned to FinalStop:

```
% Set initial seed.
persistent init
if isempty(init)
    rng(12234);
    init=true;
end
% Create random variable, x.
x=rand();
%
% Assign values within the appropriate range using the cumulative probability vector.
%
if x < 0.3
    entity.FinalStop=2;
elseif x >= 0.3 && x < 0.6
    entity.FinalStop=3;
elseif x >= 0.6 && x < 0.7
    entity.FinalStop=4;
elseif x >= 0.7 && x < 0.9
    entity.FinalStop=5;
else
    entity.FinalStop=6;
end
```

Once you generate random numbers, return to “Migration Workflow” on page 11-4.

Replace Event-Based Sequence Block with Event Actions

Replace Event-Based Sequence blocks, which generate a sequence of numbers from specified column vectors, with event actions:

```
1 persistent sequence idx
2 if isempty(sequence)
3     sequence = [3 1 4 5 2 7];
4     idx = 1;
5 end
6
7 entity.Attribute1 = sequence(idx);
8
9 idx = idx + 1;
10 if idx > length(sequence)
11     idx = 1;
12 end
```

Replace Attribute Function Blocks with Event Actions

Replace Attribute Function blocks, which manipulate attributes using MATLAB code, with event actions:

- 1 Copy the Attribute Function code, without the function syntax, to the **Event actions** tab in the relevant event action.
- 2 To refer to the entity attribute, use the format `entity.Attribute1`.

For short or simple code, use constructs like these:

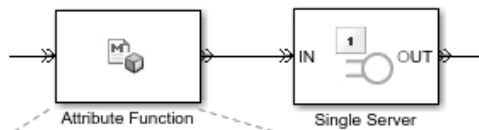

```

Attribute Function/MATLAB Function*  x  +
1  function [out_Attribute1, out_Attribute2] = fcn(Attribute1)
2  % FCN Access and modify attributes with MATLAB
3
4  -  out_Attribute1 = Attribute1 + 1;
5  -  out_Attribute2 = Attribute1*2;
6

```

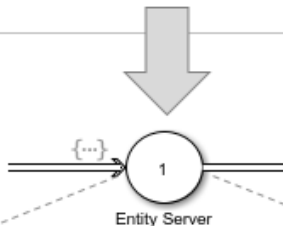

Main	Event actions	Preemption	Statistics
Event actions Entry* Service complete Exit Blocked Preempt		Entry action: Called after entity has entered this block. To access attribute use: entity.Attribute1 <pre> 1 entity.Attribute1 = entity.Attribute1 + 1; 2 entity.Attribute2 = entity.Attribute1*2; </pre>	
Entity structure entity Attribute1			

If you have longer or more complicated code, consider replacing the Attribute Function block with a Simulink Function and copying the code without modification into the Simulink Function block.

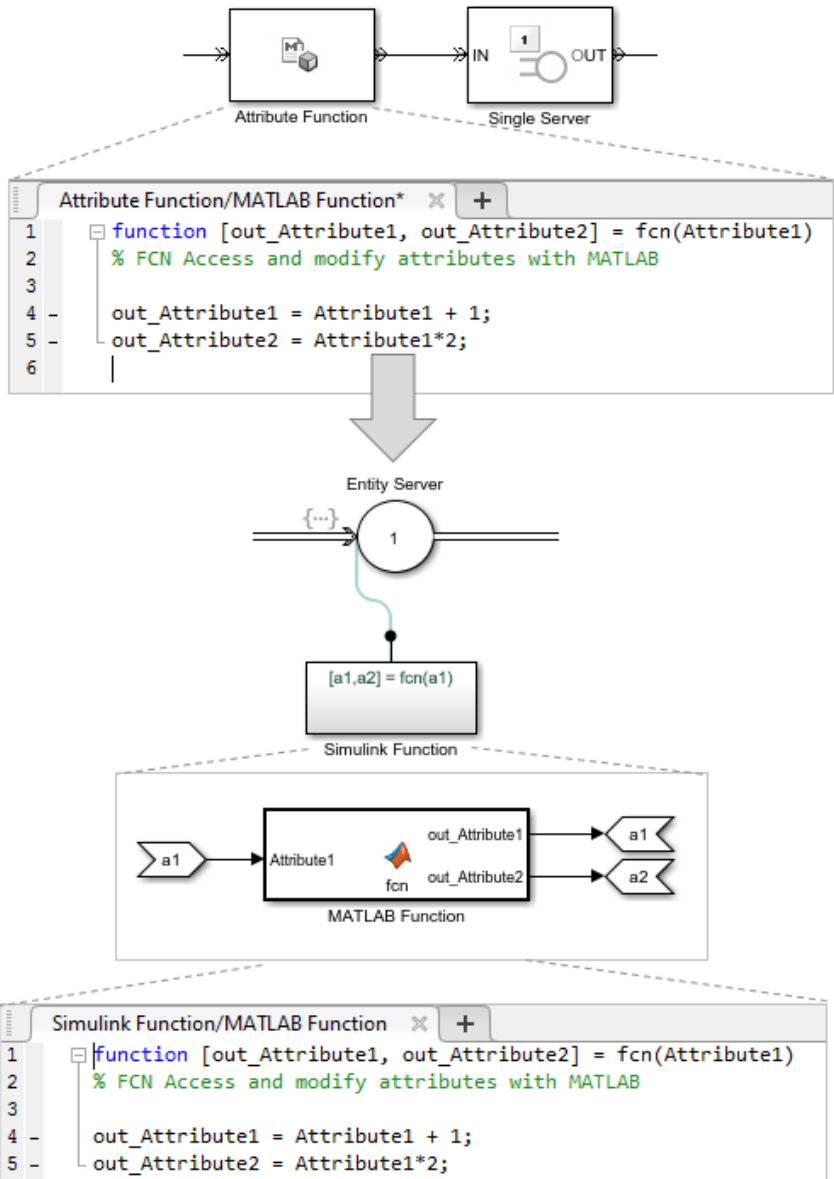

Return to “Migration Workflow” on page 11-4.

If Using Simulink Signals in an Event-Based Computation

If you are using Simulink signals in an event-based computation, send the signals to a Simulink Function block.

- 1 Copy the event-based computation code to a Simulink Function block.
- 2 Send the Simulink signals as inputs to the Simulink Function block.

For example:

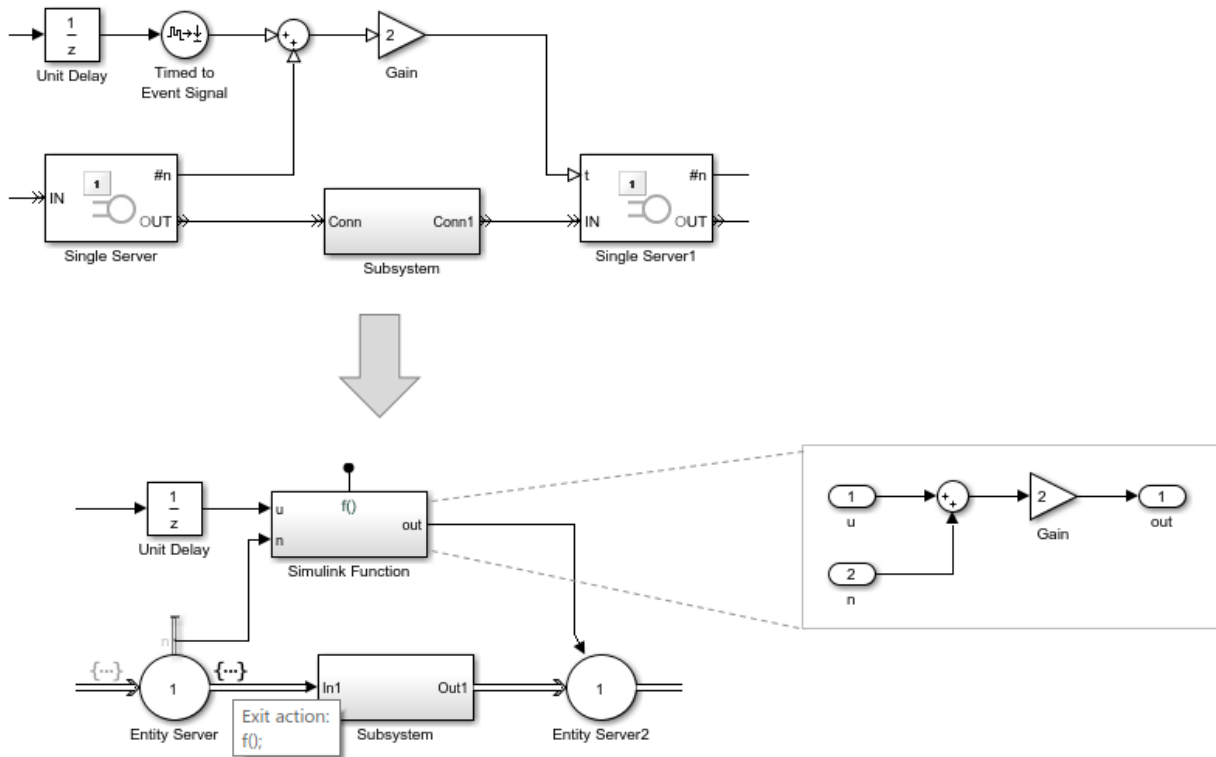

See Also

More About

- “Migration Considerations” on page 11-2
- “Migration Workflow” on page 11-4
- “Identify and Redefine Entity Types” on page 11-7
- “Replace Old Blocks” on page 11-9
- “Connect Signal Ports” on page 11-13
- “Observe Output” on page 11-29
- “Reactive Ports” on page 11-31

Observe Output

Use these methods to observe output from your SimEvents model:

Items to Observe	Visualization Tool
Statistics	<ul style="list-style-type: none"> Simulation Data Inspector
Entities passing through model	<ul style="list-style-type: none"> Simulink To Workspace block Simulink Scope block
Attributes	<ul style="list-style-type: none"> Simulink Display block Simulink To File block Simulink Dashboard blocks
Count simultaneous entities and messages	Simulation Data Inspector
Count simultaneous events	Simulation Data Inspector — Each event is now a message reactive port
Entities moving through blocks in the model	Sequence Viewer
Entity animation	Display > Message Animation
Step through Simulation	Simulink Simulation Stepper
Custom animation	SimEvents custom visualization API.

Return to “Migration Workflow” on page 11-4.

See Also

More About

- “Migration Considerations” on page 11-2
- “Migration Workflow” on page 11-4
- “Identify and Redefine Entity Types” on page 11-7
- “Replace Old Blocks” on page 11-9
- “Connect Signal Ports” on page 11-13

- “Write Event Actions for Legacy Models” on page 11-19
- “Reactive Ports” on page 11-31

Reactive Ports

In previous releases, reactive ports are signal input ports that listen for updates or changes in the input signal. When the input signal changes, an appropriate reaction occurs in the block possessing the port. Convert all reactive port event signals to messages.

Here is an example of sending a message when data is less than or equal to 0.

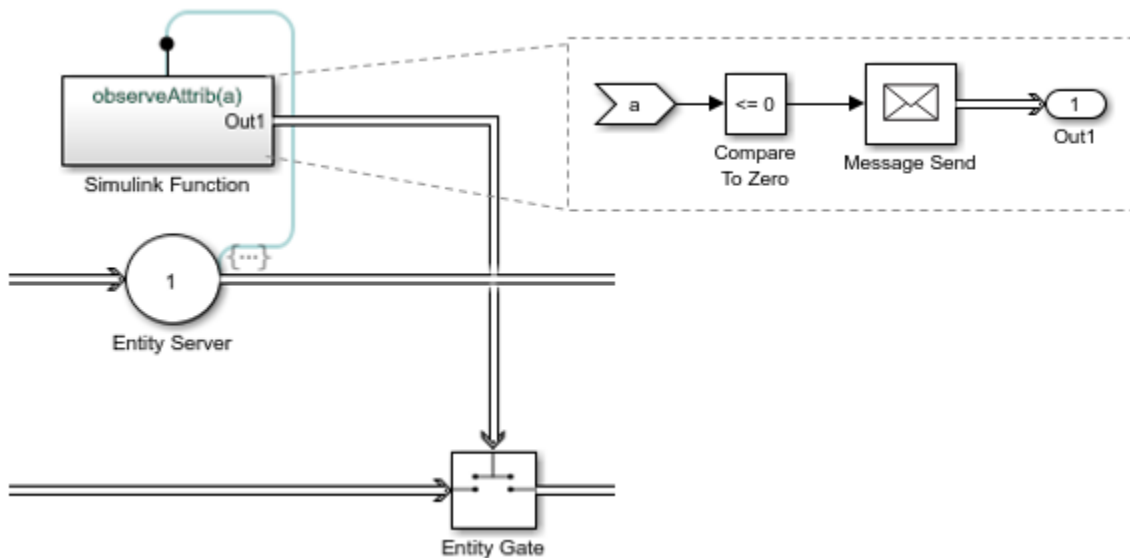

Here is an example of sending messages on trigger edges (rising, falling, or either).

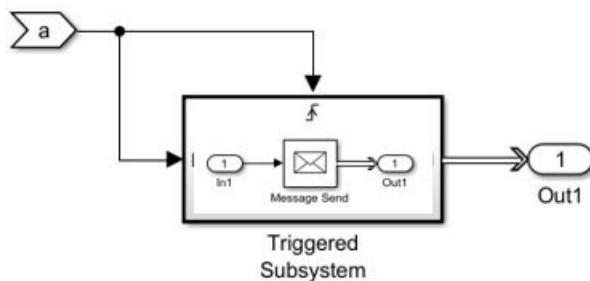

Here is an example of sending messages based on value changes (rising, falling, or either).

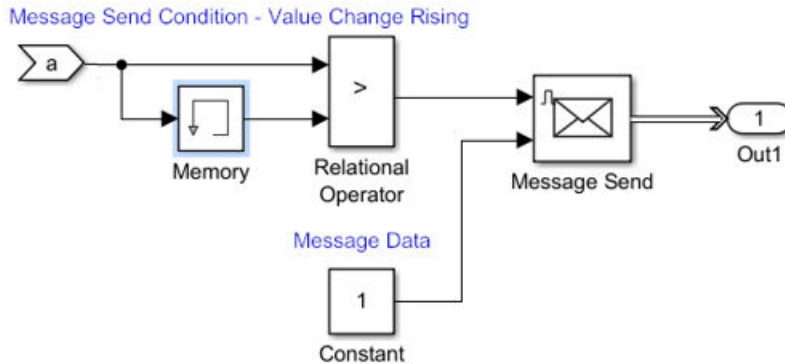

Here is a list of the reactive ports in SimEvents blocks and the action you can take for them.

List of Reactive Ports

New Block with Reactive Port	Reactive Port Behavior	Action in New SimEvents Model
Entity Gate	To open a gate on an event	In enabled mode, send a message that carries a positive value to the port on the Entity Gate block. In receive mode, send a message to advance one entity for each message that arrives on the control port.
Entity Input Switch Entity Output Switch	Value change	To select a new port, send a message to the control port of the Entity Input Switch or Entity Output Switch.
Entity Generator	Message arrival	Send a message to create an event-based entity.

Return to “Migration Workflow” on page 11-4

See Also

More About

- “Migration Considerations” on page 11-2
- “Migration Workflow” on page 11-4
- “Identify and Redefine Entity Types” on page 11-7
- “Replace Old Blocks” on page 11-9
- “Connect Signal Ports” on page 11-13
- “Write Event Actions for Legacy Models” on page 11-19
- “Observe Output” on page 11-29

Troubleshoot SimEvents Models

Debug SimEvents Models

A breakpoint is a point of interest in the simulation at which the debugger can suspend the simulation. SimEvents Debugger allows you to inspect entities, set breakpoints based on entities leaving or entering storage elements, and step to events.

To enable debugging for a SimEvents model, add the SimEvents Debugger block to the model. When you click **Step Forward** in the Simulink Toolstrip, the SimEvents Debugger displays.

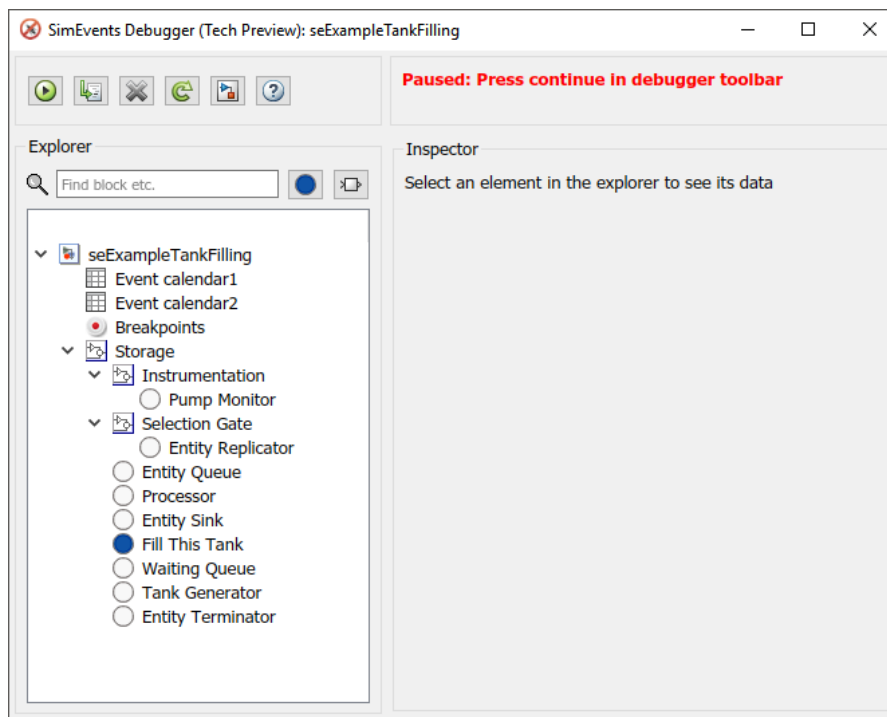

The **Explorer** pane contains these nodes:

- **Event calendar** — Maintains a list of current and pending events for the model. Select the **Break before event execution** check box to display event breakpoints on the **Breakpoints** node.
- **Breakpoints** — Lists the breakpoints previously set for the model. You can view breakpoints set for the block, on event calendar, and for watched entities.

- **Storage** — Displays the entity inspector listing all the storage blocks in the model and check boxes that let you select breakpoints. Blocks that contain entities are denoted with .

To set breakpoints for post entry and pre-exit of entities, select the **PostEntry Break** and **PreExit Break** check boxes.

- *Entity Queue* — Displays the entity inspector listing the entities and attributes associated with that block.

SimEvents Debugger is used in the Tank Filling Station example to step through the model simulation, to set breakpoints, and to explore the event calendar.

The SimEvents software also provides an API that helps you to create your own visualization and debugging tools. For more information, see “Use SimulationObserver Class to Monitor a SimEvents Model” on page 10-2.

Start the Debugger

- 1 Start Tank Filling Station.
- 2 Into the Simulink editor, add the SimEvents Debugger block at the top of the Tank Filling Station model.
- 3 To start the debugger, in the Simulink editor toolbar, click the **Step Forward** button.

The debugger displays in a paused state.

- 4 To step to the next event, click .

Note You can also click **Continue** () to have the debugger continue the simulation. However, doing so without setting breakpoints causes the simulation to complete and the debugger to close.

- 5 The debugger pauses at the next event and displays it in the event calendar. The current event is highlighted in green.

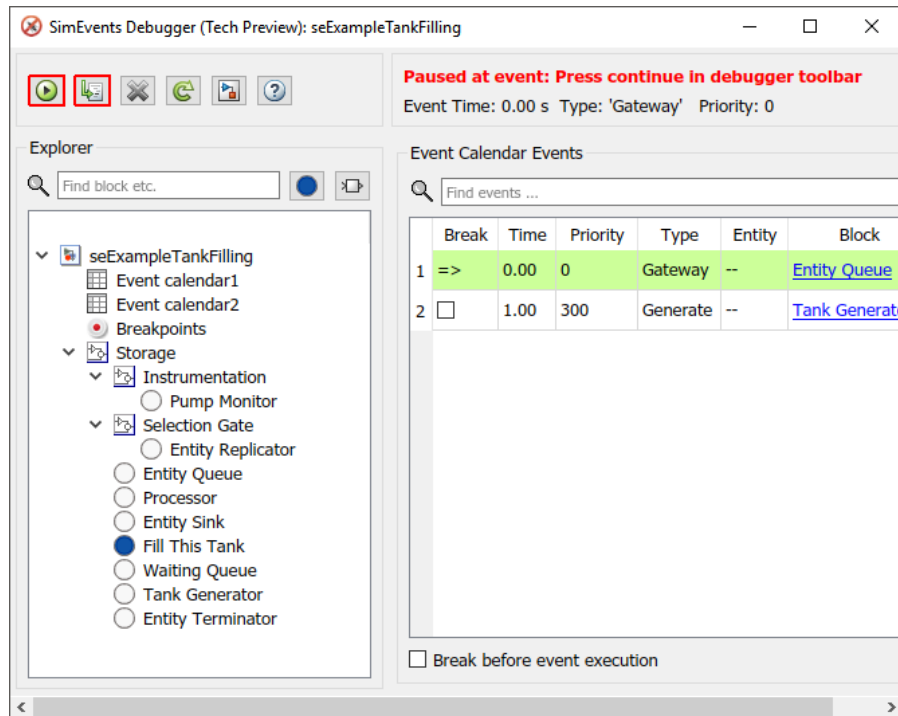

Step Through Model

- 1 To look at the current and scheduled events, click the **Event calendar1** item. To set breakpoints, you can select the **Break before event execution** check box. The debugger hits the breakpoint before the next scheduled event. This breakpoint is for any event type, including Forward, Generate, ServiceComplete, Gateway, Destroy, and Trigger. Do not select this check box now.

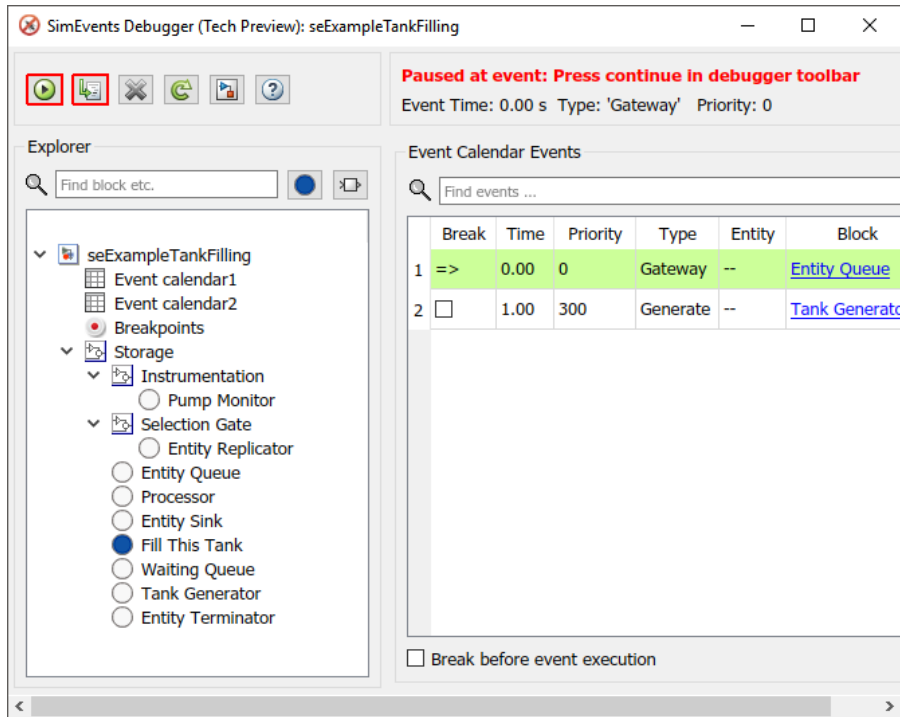

- 2 To inspect the attributes of an entity, click the **Fill This Tank** storage element in the **Explorer** pane.

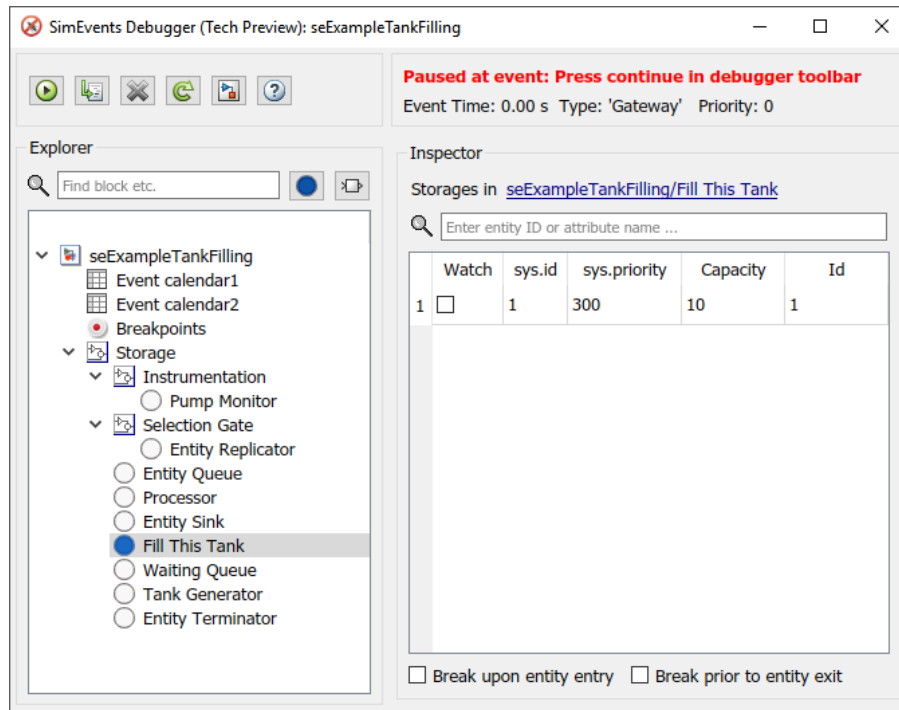

- 3 The **Inspector** pane shows a table with the entity `sys.id`. To track the entity as the model simulates, click the associated check box.
- 4 To set breakpoints for when this entity enters and leaves the block, at the bottom of the **Inspector** pane, select the two check boxes **Break upon entity entry** and **Break prior to entity exit**.

Alternatively, to set the breakpoints on storage blocks all at once, click the **Storage** item in the **Explorer** pane. Notice that the **Fill This Tank** block is highlighted because it contains entities.

Select the **PostEntry Break** check boxes for the blocks you want in this table.

- 5 To progress to the next event, click .

- 6 Click **Continue**. Simulation continues until the next `PostEntry` or `PreExit` event.

The screenshot displays the SimEvents Debugger interface for a model named 'seExampleTankFilling'. The main window is titled 'Paused at event: Press continue in debugger toolbar'. Below this, it shows the current event details: 'Event Time: 1.00 s Type: 'Forward' Priority: 300'. The 'Inspector' pane shows 'Storages in seExampleTankFilling/Fill This Tank' with a table listing entity details.

Watch	sys.id	sys.priority	Capacity	Id
<input type="checkbox"/>	1	300	10	1
<input type="checkbox"/>				

The Explorer pane on the left shows a tree view of the model's components, with 'Fill This Tank' selected under the 'Storage' category. The main diagram area shows the 'Tank Filling Station' model, which is a 'Mixed Discrete Event & Continuous System'. It is divided into three main sections: 'Discrete-Event Process', 'Pump - Tank Model', and 'Interface'. The 'Discrete-Event Process' shows a flow from a 'Tank Generator' through a 'Waiting Queue' to a 'Fill This Tank' event, which then leads to an 'Entity Sink'. The 'Pump - Tank Model' shows a 'Gas Pump' providing flow to a 'Tank Filling' process, which is connected to a 'Tank Full' event. The 'Interface' section shows a 'Processor' that interacts with the 'Tank Full' event and a 'global' variable. The 'Fill This Tank' event in the Discrete-Event Process is highlighted in blue, indicating it is the current event being debugged.

The block associated with the breakpoint is highlighted.

- 7 Step to the next event.

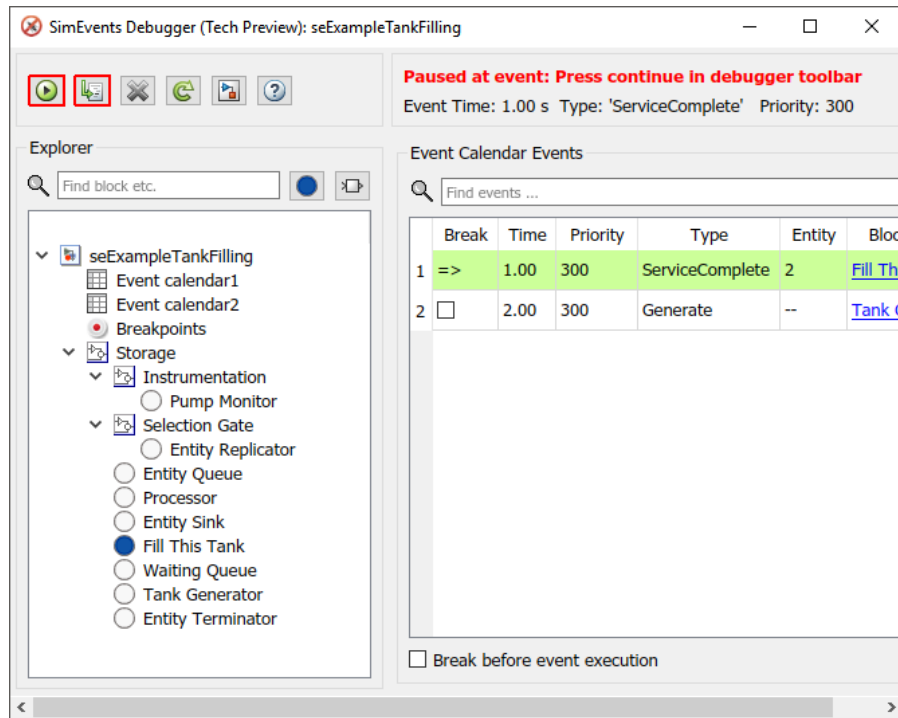

The next breakpoint at which the debugger stops is highlighted in the event calendar.

- Continue the simulation.

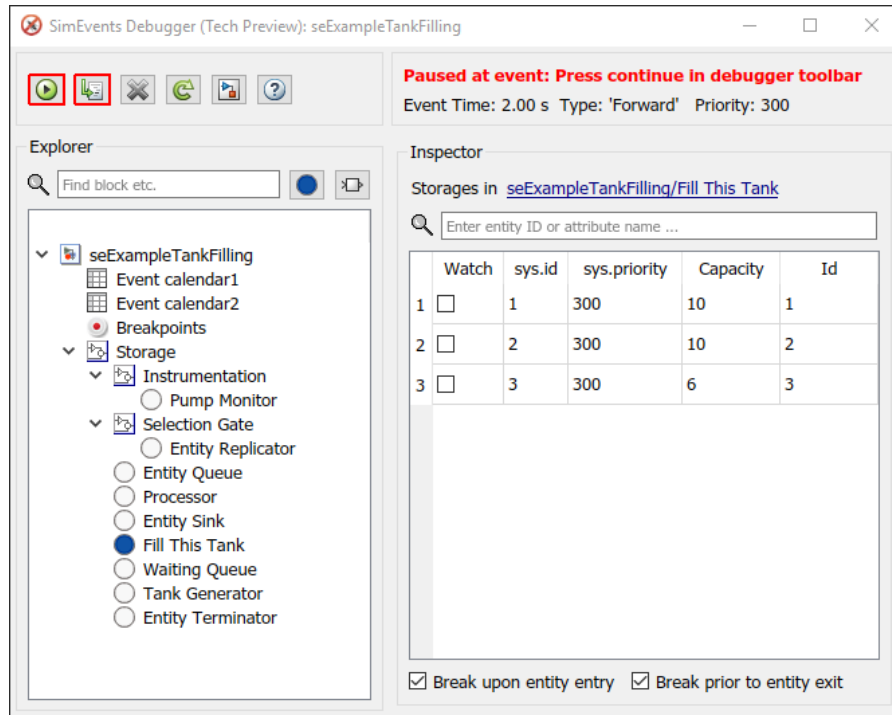

The simulation stops at the entity you opted to watch. As you continue the simulation or step through the model, the debugger stops at the various breakpoints and watchpoints that you set, letting you explore the model simulation.

- To inspect the entities in a currently selected block in the model, select the block in the model, then click the **Inspect GCB** button (.

The **Inspector** pane displays the current details of the entities in this block.

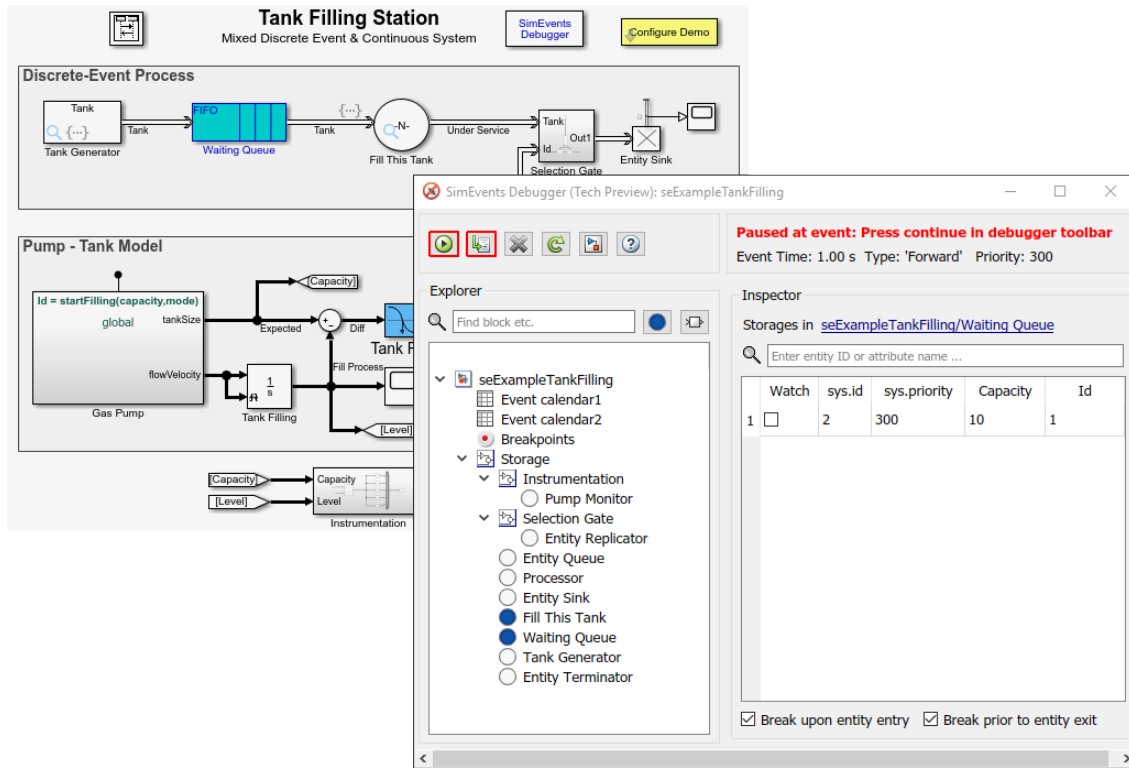

You can continue to set entity watchpoints and event breakpoints.

To list select blocks, events, or entities, type their names in the search boxes at the top of the **Explorer** or **Inspector** panes.

The SimEvents software also provides a programmatic interface that lets you create your own simulation observer or debugger. For more information, see “Create Custom Visualization”.

See Also

SimEvents Debugger

More About

- “Visualization and Animation for Debugging” on page 5-14
- “Observe Entities Using simevents.SimulationObserver Class” on page 10-8
- “Event Calendar” on page 6-2
- “Use SimulationObserver Class to Monitor a SimEvents Model” on page 10-2

